

for reliable rotation in maintenance and production



ANNO 1978

BETEX®

NEW

HYDRAULIC PULLERS

BETEX HSP 2/3-arm pullers, **self-centering**, with integrated pump and cylinder



Compact, ergonomic design, easily operated by one person!

- **Practical!**
Self-centering, easy to convert, 2-arm or 3-arm puller. The arms slide inwards or outwards simultaneously.
- **Compact!**
The self contained hydraulic pump and cylinder save space, as you don't need a separate pump, hose or puller.
- **Strong!**
The harder the force, the tighter the jaws grip. The arms cannot bend or deflect.
- **Economical!**
2/3-arm combination puller, 2 pullers for the price of one, including integrated pump and cylinder!
- **Safe!**
The integral safety release valve prevents overloading and ensures that you will never exceed the maximum power capacity.
- **Versatile!**
Various accessories are available. Sets are supplied in practical PE case and consist of a puller block, connecting rods and a set of bearing splitters.

Advantages of self-centering pullers:

- Prevents damage to shaft and object being pulled.
- Efficient and saves time.
- Can be used in any position.
- Adaptors included.

4, 6, 8, 12, 20 or 30 ton capacity!

PATENTED DESIGN

BETEX HSP 2/3 HYDRAULIC SELF-CENTERING PULLERS

Type	Art.no.	Cap. ton	Max. shaft length mm	Max. spread mm	Stroke mm	A	B	C	D	E	F	G	Weight Kg
HSP 43	791500	4	190	325	60	13	10	22	-	40	42	22	8.0
HSP 63	792500	6	230	380	70	13	10	22	-	50	45	23	10.0
HSP 83	793500	8	280	450	85	13	13	27,5	-	70	50	25	12.0
HSP 123	794500	12	305	485	85	15	16,5	29	-	70	60	28	15.0
HSP 203	796500	20	365	570	111	20	27	33	-	62	80	40	25.0
HSP 303	797500	30	465	680	111	20	27	38	-	85	98	50	36.0

ACCESSORY SETS FOR 4, 6, 8 AND 12 TON PULLERS

Puller block, connecting rods, incl. set of bearing splitters for min/max Ø 25-225 mm

Type	Art.no.	Shaft length mm	min./max. spread mm	Weight Kg
Acc. Set HSP 43	791100	250	Ø 25-110	8.5
Acc. Set HSP 63	792100	280	Ø 50-150	12.5
Acc. Set HSP 83	793100	280	Ø 50-150	12.5
Acc. Set HSP 123	794100	325	Ø 80-225	18.0

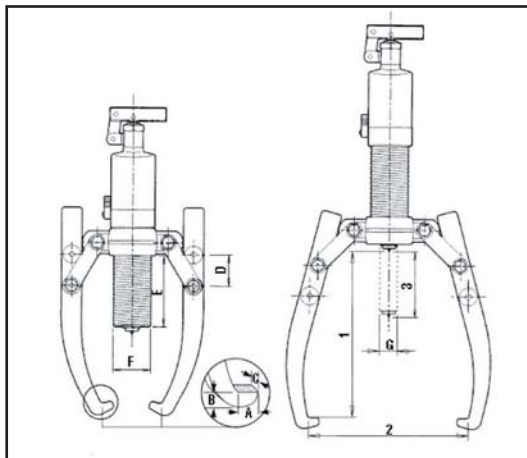

2-stage pump: the HSP 20 and 30 ton models are equipped with an innovative 2-stage pump, making pumping easier and therefore safer.

Convenient: the 360° rotatable pump handle provides flexibility for using the puller in the most convenient position. The telescopic pump handle ensures optimal force transmission.

