

SAMICK

LINEAR MOTION SYSTEM

 **SAMICK PRECISION IND.CO.,LTD.**

CATALOG NO. 2501E

SAMICK LINEAR MOTION SYSTEM

IMAGE MAP

**Linear
Bushing**

**Self-Aligning
Linear Bushing**

LMES



P. 056

LMES_OP

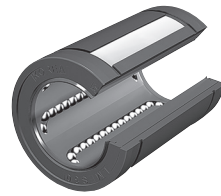

P. 058

LMBS



P. 060

LMBS_OP

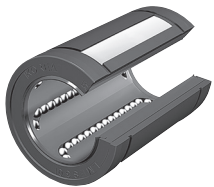

P. 062

CLB

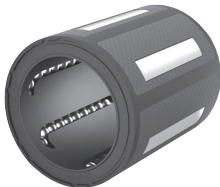

P. 064

**SUS SERIES
Self-Aligning
Linear Bushing**

LMES-SUS



P. 066

LMES_OP-SUS

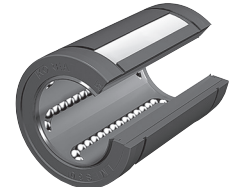

P. 068

LMBS-SUS



P. 070

LMBS_OP-SUS

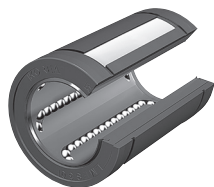

P. 072

CLB-SUS

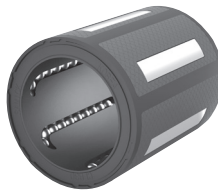

P. 074

**Asian Standard
Linear Bushing**

LM



P. 078

LM_L



P. 080

LM_AJ



P. 082

LM_OP



P. 084

LMF



P. 086

LMF_L



P. 088

LMK

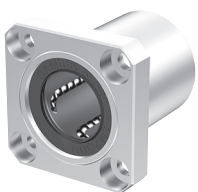

P. 090

LMK_L

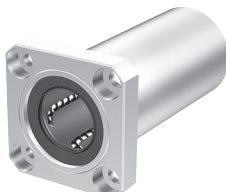

P. 092

LMH



P. 094

LMH_L



P. 096

LMFP



P. 098

LMFP_L



P. 100

LMKP

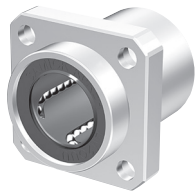

P. 102

LMKP_L

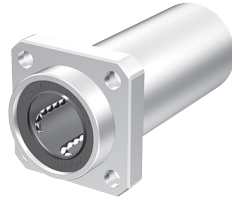

P. 104

LMHP



P. 106

LMHP_L



P. 108

LMFM



P. 110

LMKM

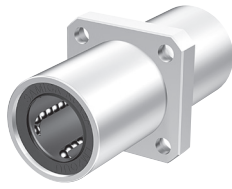

P. 112

LMHM



P. 114

European
Standard Linear
Bushing

LME



P. 118

LME_L



P. 120

LME_AJ



P. 122

LME_OP



P. 124

LMEF



P. 126

LMEF_L



P. 128

LMEK

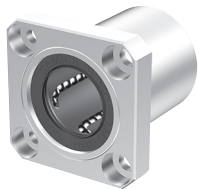

P. 130

LMEK_L

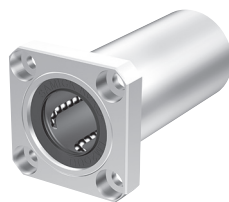

P. 132

LMEFP



P. 134

LMEFP_L



P. 136

LMEKP

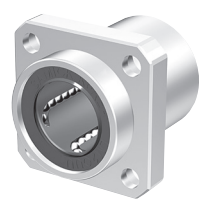

P. 138

LMEKP_L

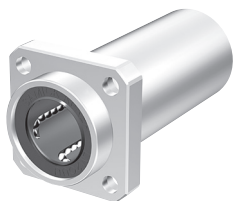

P. 140

LMEFM



P. 142

LMEKM

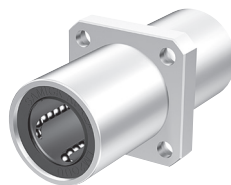

P. 144

Aluminum
Case Unit

SC



P. 148

SCW



P. 150

SCW_N



P. 152

SCV

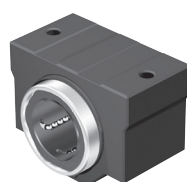

P. 154

SCJ

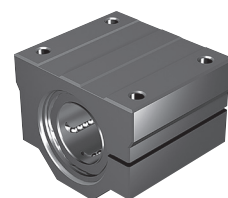

P. 156

SBR

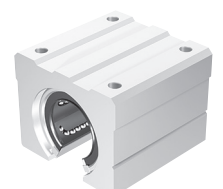

P. 158

TBR

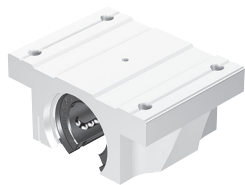

P. 160

SCE



P. 162

SCE_W



P. 164

SCE_V

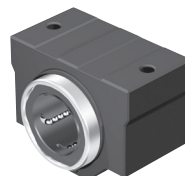

P. 166

SCB



P. 168

SCB_OP

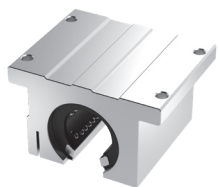

P. 170

SLB



P. 172

SLB_OP

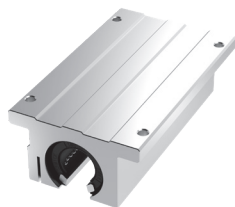

P. 174

SUS SERIES
Asian Standard
Linear Bushing

LM-SUS



P. 178

LM_L-SUS



P. 180

LM_AJ-SUS



P. 182

LM_OP-SUS



P. 184

LMF-SUS



P. 186

LMF_L-SUS



P. 188

LMK-SUS

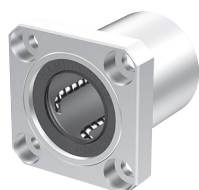

P. 190

LMK_L-SUS

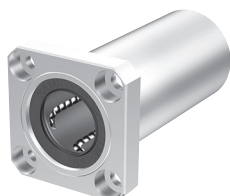

P. 192

LMH-SUS



P. 194

LMH_L-SUS



P. 196

LMFP-SUS



P. 198

LMFP_L-SUS



P. 200

LMKP-SUS



P. 202

LMKP_L-SUS



P. 204

LMHP-SUS



P. 206

LMHP_L-SUS



P. 208

LMFM-SUS



P. 210

LMKM-SUS

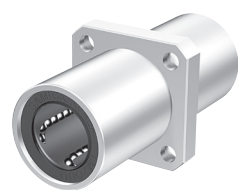

P. 212

LMHM-SUS



P. 214

SUS SERIES
European
Standard Linear
Bushing

LME-SUS



P. 218

LME_L-SUS



P. 220

LME_AJ-SUS



P. 222

LME_OP-SUS



P. 224

LMEF-SUS



P. 226

LMEF_L-SUS



P. 228

LMEK-SUS

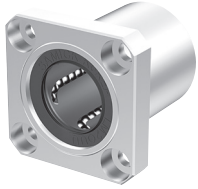

P. 230

LMEK_L-SUS

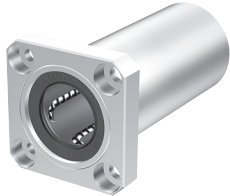

P. 232

LMEFP-SUS



P. 234

LMEFP_L-SUS



P. 236

LMEKP-SUS



P. 238

LMEKP_L-SUS

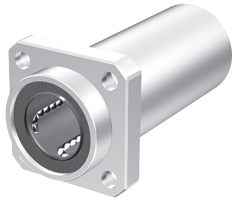

P. 240

LMEFM-SUS



P. 242

LMEKM-SUS

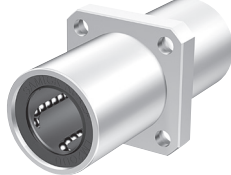

P. 244

SUS SERIES
Aluminum Case
Unit

SC-SUS



P. 248

SCW-SUS



P. 250

SCW_N-SUS



P. 252

SCV-SUS

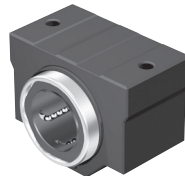

P. 254

SCJ-SUS

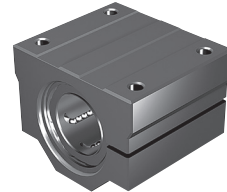

P. 256

SBR-SUS

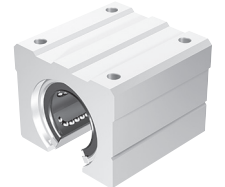

P. 258

TBR-SUS

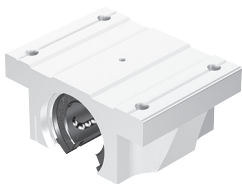

P. 260

SCE-SUS



P. 262

SCE_W-SUS



P. 264

SCE_V-SUS

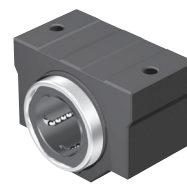

P. 266

SCB-SUS



P. 268

SCB_OP-SUS



P. 270

SLB-SUS



P. 272

SLB_OP-SUS

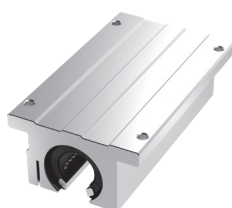

P. 274

LM Shaft &
Support Rail
Unit

SBS



P. 280

TBS



P. 282

SK

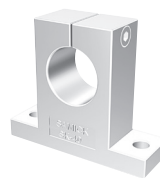

P. 284

SF



P. 286



The copyright of the contents of this publication is obtained by SAMICK Precision Ind. Co., Ltd.

Every care has been taken to ensure the contents and all data has been checked for their accuracy, but no liability can be accepted to us for any incorrect or incomplete data. We reserve the right to modify the contents inside. And because of continuous improvement and development, contents can be modified by us without any prior notice. All information and pictures in this publication are illustrative purpose only. No responsibility for the consequences caused by user's own estimation can be assumed to us.

Published by **SAMICK Precision Ind. Co., Ltd.**

**(P.C 42721) 39 Seongseogongdannam-ro 32-gil, Dalseo-gu,
Daegu, Korea (South)**

Telephone **+82-53-666-7100** Fax **+82-53-583-4669** Web site **www.mysamick.com**

E-mail **marketing@mysamick.com**

publication No. 2501E

Contents

004	Image Map
013	Linear Bushing Intro
025	SAMICK Linear Bushing
041	Technical Information
049	Super Ball Self-Aligning Linear Bushing Technology of Product European Standard of Linear Bushing US Standard Linear Bushing Compact Linear Bushing(CLB)
077	Asian Standard of Linear Bushing Standard Type Standard Flanged Type Pilot Flanged Type Middle Flanged Type
117	European Standard Linear Bushing Standard Type Standard Flanged Type Pilot Flanged Type Middle Flanged Type
147	Aluminium Case Unit Asian Standard Asian Standard Open Type European Standard
177	SUS Series Asian Standard Linear Bushing
217	SUS Series European Standard Linear Bushing
247	SUS Series Aluminium Case Unit
277	LM Shaft & Support Rail Unit Support Rail Unit LM Shaft Support LM Shaft
289	References

Overall Linear Bushing technology by SAMICK

Look at the technology here,
and feel the Instinct of Linear Art at the field.

13

Linear Bushing Intro



Self-Aligning Linear Bushing

- High load Capacity and long travel life
 - Interchangeable with European & American Type Standard Linear Bushing
 - Travel speeds up to 10ft/s (3m/s) and smooth operation
 - Easy of installation as a result of self-aligning Ball plates ($\pm 0.5^\circ$)
 - Anti-Rusting: Nickel or Chrome Plating, Raydent Treatment of ball plate, Stainless Steel Ball Plate(Under LMES12, LMBS08), Stainless-Steel Ball
- LMES, LMES_OP : European Standard(mm), p56~59**
LMBS, LMBS_OP : American Standard(inch), p60~63



Compact Linear Bushing

- Economic product used for variety of application
 - Compact size resolving space restriction
 - Easy Assembly : No need additional accessory
 - Housing applicable for anti-rusting, etc
 - 100% interchangeable : perfectly interchange with other companies' compact series
- CLB, p64~65**



SUS SERIES Self-Aligning Linear Bushing

- High load Capacity and long travel life
 - Interchangeable with European & American Type Standard Linear Bushing
 - Travel speeds up to 10ft/s (3m/s) and smooth operation
 - Easy of installation as a result of self-aligning Ball plates ($\pm 0.5^\circ$)
 - Anti-Rusting: Nickel or Chrome Plating, Raydent Treatment of ball plate, Stainless Steel Ball Plate(Under LMES12, LMBS08), Stainless-Steel Ball
- LMES, LMES_OP : European Standard(mm), p66~69**
LMBS, LMBS_OP : American Standard(inch), p70~73



SUS SERIES-Compact Linear Bushing

- Reasonable price Linear Bushing for diverse applications
 - Compact size for reasonable design
 - Easy Assembly : press to fit and no need for additional accessory
 - Anti-rust effect by applying stainless steel material to ball plates and balls
- CLB, p74~75**
-



Standard Linear Bushing

- Allowed Max. 10130N the basic dynamic load rating
- Shaft diameter from 5mm to 100mm
- Provide low friction on high-speed movement
- Can be selected resin retainer (standard), and steel retainer (for high temperature & vacuum)
- Corrosion-resisting : The nickel-plated and Rayden treatment on outer sleeves and stainless steel ball

LM, LM_L, LM_AJ, LM_OP : Asian standard, p78~85

LME, LME_L, LME_AJ, LME_OP : European standard, p118~125

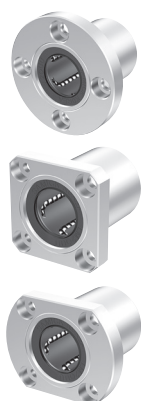

Flanged type Linear Bushing

- With a variety of design and easy installation
- Used in case of load directly applied to Linear Bushing
- Can be selected resin retainer (standard), and steel retainer (for high temperature & vacuum)
- Corrosion-resisting: the nickel-plated, Raydent treatment of Outer-sleeves, stainless steel ball

LMF_(L), LMK_(L), LMH_(L) : Asian standard, p86~97

LMEF_(L), LMEK_(L) : European standard, p126~133



Pilot Flanged type Linear Bushing

- With a variety of design and easy installation
- When the load directly apply to Linear Bushing, the Pilot Flange can get more stable motion movement and the most suitable against moment load
- Installed without housing
- Can be selected resin retainer (standard), and steel retainer (for high temperature & vacuum)
- Corrosion-resisting: the nickel-plated, Raydent treatment of Outer-sleeves, stainless steel ball

LMFP_(L), LMKP_(L), LMHP_(L) : Asian standard, p98~109

LMEFP_(L), LMEKP_(L) : European, p134~141



Middle Pilot Flanged type Linear Bushing

- With a variety of design and installation
- When the load directly apply to Linear Bushing, the Middle Flange can get more stable motion and the most suitable against moment load on both sides of the moving body
- Installed without housing
- Can be selected resin retainer (standard), and steel retainer (for high temperature & vacuum)
- Corrosion-resisting: the nickel-plated, Raydent treatment of Outer-sleeves, stainless steel ball

LMFM, LMKM, LMHM : Asian standard, p110~115

LMEFM, LMEKM : European standard, p142~145



Aluminum Case Unit

- Linear Bushing with Aluminium housing and standard or self-aligning
- Aluminum housing with high precision and lightweight
- Abnormal deformation does not occur within rated load
- Minimized surface scratch

SC, SC_W, SC_V, SCJ : Asian standard, p148~157

SCE, SCE_W, SCE_V : European standard, p162~167

SCB, SCB_OP, SLB, SLB_OP : American Standard, p168~175



Aluminum Case Unit (Open Type)

- Open type Aluminium housing and Linear Bushing
- Aluminum housing with a high hardness and lightweight
- Combined with support rail

SBR, TBR : Asian standard, p158~161



SUS SERIES-Linear Bushing

- Outer-sleeve and ball : stainless steel for corrosion resistance
- Can be selected by LM Shaft diameter 5~30mm
- Can be selected resin retainer (standard), and steel retainer (for high temperature & vacuum) (LM05, LM08S resin retainer only)

LM, LM_(L), LM_AJ, LM_OP : Asian standard, p178~185

LME, LME_(L), LME_AJ, LME_OP : European standard, p218~225



SUS SERIES-Flanged Linear Bushing

- Outer-sleeve, ball and flange : stainless steel for corrosion resistance
- With a variety of design and easy installation
- Used when the load of moving body passed directly to the Linear Bushing
- Installed without housing
- Can be selected resin retainer (standard), and steel retainer (for high temperature & vacuum)

LMF_(L), LMK_(L), LMH_(L) : Asian standard, p186~197

LMEF_(L), LMEK_(L) : European standard, p226~233



SUS SERIES-Pilot Flanged Linear Bushing

- Outer-sleeve, ball and flange : used stainless steel, corrosion-resistance products
- With Variety of design and ease of installation
- The Middle Flange can get more stable motion and being the most suitable for moment load
- Installed without housing
- Can be selected resin retainer (standard), and steel retainer (for high temperature & vacuum)

LMFP_(L), LMKP_(L), LMHP_(L): Asian standard, p198~209

LMEFP_(L), LMEKP_(L): European standard, p234~241



SUS SERIES-Middle Pilot Flanged type Linear Bushing

- Outer-sleeve, ball and flange: used stainless steel, corrosion-resistance products
- With a Variety of design and ease of installation
- When the load of moving body passed directly to the Linear Bushing, can get more stable motion for moment load
- Installed without housing
- Can be selected resin retainer (standard), and steel retainer (for high temperature & vacuum)

LMFM, LMKM, LMHM : Asian standard, p210~215

LMEFM, LMEKM : European standard, p242~245



Support Rail Unit

- Integration of aluminum rail and shaft
 - Combined with open type Aluminum Case Unit
- SBS, TBS : Asian, European standard, p280~283**



LM Shaft / Shaft Support

- High carbon bearing steel shaft (Surface treatment and chamfering is Available)
- Corrosion-resisting: Stainless steel LM Shaft
- Aluminum shaft support

SK : Shaft support, Asian, European standard, p284~285

SF : LM Shaft, Asian, European standard, p286~287

PART NUMBER NOTATION

● Self-aligning Linear Bushing

LM ES 16 UU OP - N S

● SAMICK Linear Bushing

● Standard Selection(Europe, US)

ES	Metric series (mm)
BS	Inch series (inch)

● Nominal Shaft Diameter

10~50mm	Metric (mm)
#4~#32	Inch Series

● Seal

Blank	No Seal
UU	Both Side Seal
U	One Side Seal

● Sloting Type

Blank	Standard type
OP	Open type(for support rail)

● Corrosion resistance type

Blank	Stainless steel
N	Electroless nickel plating

● Ball type (material)

Blank	Standard(High Carbon Chromium Bearing Steel Ball)
S	Stainless steel ball

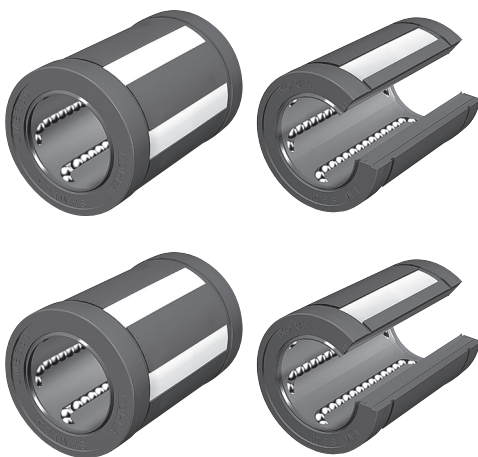

PART NUMBER NOTATION

● Compact Linear Bushing

CLB 20 UU - SUS

● Compact Linear Bushing

● Nominal Shaft Diameter

● Seal

Blank	No Seal
UU	Both Side Seal
U	One Side Seal

● Outer-Sleeve : POM

● Ball type : Stainless Steel

● Retainer : POM

● Ball plate : Stainless Steel

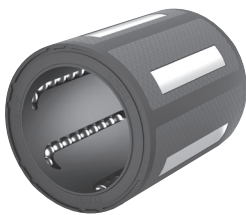

PART NUMBER NOTATION

● LINEAR BUSHING

LM E F P 20 L UU OP - A N S

● SAMICK Linear Bushing

● Standard Option(Europe, US)

Blank	Asian Standard
E	European Standard

● Flange Option

Blank	Standard
F	Circular type
K	Square type
H	Oval type

● Flange Location

Blank	Standard
P	Pilot
M	Middle

● Nominal Shaft Diameter

5~80mm	Standard
6~80mm	Flange

● Length

Blank	Standard
L	Long

● Seal

Blank	No Seal
UU	Both Side Seal
U	One Side Seal

● Sloting Type

Blank	Standard type
OP	Open type(for support rail)
AJ	Adjustable type

● Retainer (material)

Blank	Resin Retainer(Standard)
A	Steel Retainer (High temperature)*1

● Outer-sleeves (by corrosion resistance)

Blank	Resin retainer(Standard)
N	Electroless nickel plating
R	Raydent treatment

● Ball type (material)

Blank	Standard(High Carbon Chromium Bearing Steel Ball)
S	Stainless steel ball



★1 Steel retainer 06mm to 30mm only(LM08S Resin retainer only)

PART NUMBER NOTATION

● Aluminum Case Unit

SC E J 20 W UU N - A N S

● SAMICK Aluminum Case Unit (with Standard Linear Bushing)

● Standards

Blank	Asian Standard
E	European Standard

● Clearance adjustable type*¹

Blank	Standard
J	Clearance adjustable type (Asian standard only:J)

● Nominal Shaft Diameter

8-50mm	Metric(mm)
--------	------------

● Case unit length

Blank	Standard
V	Compact type
W	Long type

● Sea

Blank	No Seal
UU	Both Side Seal
U	One Side Seal

● New Type(Interchangeable with Asian type)

● Retainer (material)*²

Blank	Resin Retainer(Standard)
A	Steel Retainer(High temperature)* ⁴

● Outer-sleeves (by corrosion resistance)

Blank	Resin retainer(Standard)
N	Electroless nickel plating
R	Raydent treatment

● Ball type (material)

Blank	Standard(High Carbon Chromium Bearing Steel Ball)
S	Stainless steel ball

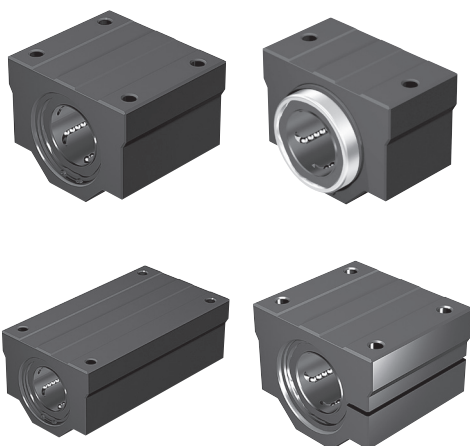

★¹ Clearance adjustable type aluminum housing unit applies only to the Asian standard and the Nominal Shaft Diameter
Selection is possible between 10mm to 50mm

★² Steel retainer applies only to Asian standard and European standard

★³ It can combine with self-aligning linear bushing (SCE type)

★⁴ Diameter ø8-ø30 Only

PART NUMBER NOTATION

● Aluminum Case Unit (Open type)

SBR 20 UU - N S

● SAMICK Aluminum Case Unit (Open type)

SBR	Open type Aluminum Case Unit (Standard type)
TBR	Open type Aluminum Case unit (Clearance adjustable type)

● Nominal Shaft Diameter*1

16~50mm

● Seal

Blank	No Seal
UU	Both Side Seal
U	One Side Seal

● Outer-sleeves (by corrosion resistance)

Blank	Standard
N	Electroless nickel plating
R	Raydent treatment

● Ball type (material)

Blank	Standard(High Carbon Chromium Bearing Steel Ball)
S	Stainless steel ball

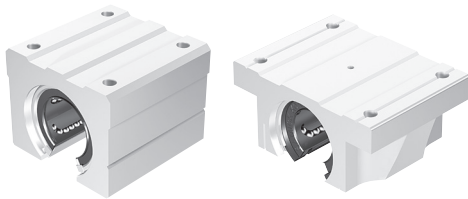

★1 SBR's nominal shaft diameter:16~50mm, TBR's nominal shaft diameter:16~30mm

★2 By default, open type case unit cannot combine with a self-aligning linear bushing but some of the model is available with self-aligning linear bushing. Please contact Samick.

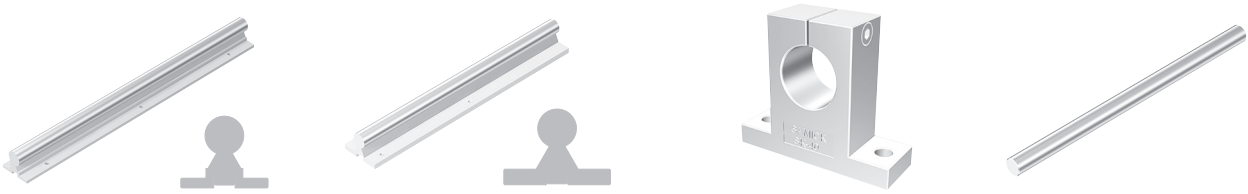

PART NUMBER NOTATION

● Support Rail Unit

SBS C g6 30 - 1000 L

● SAMICK Support Rail Unit

SBS	Support Rail Unit for SBR
TBS	Support Rail Unit for TBR

● Shaft (by corrosion resistance)

Blank	No plating (Standard)
C	Chrome plated shaft
N	Nickel plated shaft* ¹
R	Raydent treated shaft

● Shaft tolerance

g6	Asian standard
h6	European standard

● Shaft Diameter

16~50mm

● Shaft Length

100~3,000mm

● LM Shaft

SF C g6 30 - 1000 L

● Samick LM Shaft

● Shaft (by corrosion resistance)

Blank	No plating (Standard)
C	Chrome plated shaft
N	Nickel plated shaft* ¹
R	Raydent treated shaft

● Shaft tolerance

g6	Asian standard
h6	European standard

● Shaft Diameter

5~80mm

● Shaft Length

100~3,00mm

● LM Shaft Support

SK 20

● SAMICK LM Shaft Support(Aluminum)

● Shaft Diameter

8~40mm

★1 The length should be less than 1m

Structure and Special Features

● Self-Aligning Linear Bushing

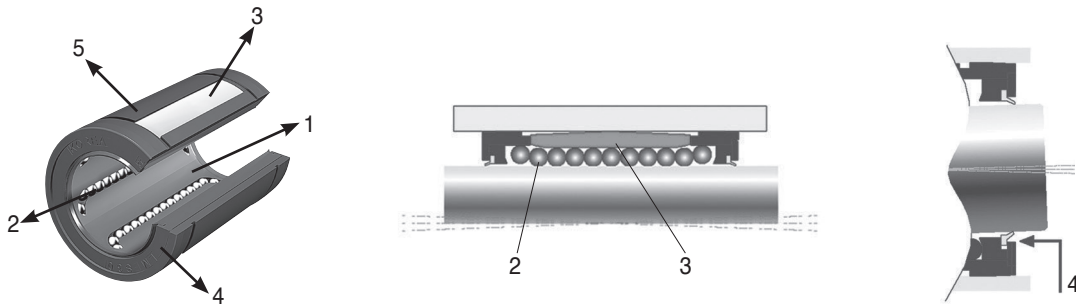

Part	Material	Special features and function
1 Retainer	- POM	- Guide ball's Motion - An essential element of unlimited linear stroke
2 Ball	- Standard(High Carbon Chromium Bearing Steel Ball) - Stainless steel - Ceramic	- the support of the load by direct contact between shaft and ball plate - An essential element for low friction, high load capacity, high precision and high speed stroke
3 Ball plate	- High carbon bearing steel - Stainless steel * available Corrosion resistance plating	- Direct contact with the ball to the receiving portion of the load - Stand on a high load with the ball groove. - a key part of the self-aligning linear bushing to perform self-aligning
4 Rubber Seal	- NBR * optional item	- Direct contact with shaft - Preventing a foreign substance from outside - Preventing outflow of lubricant by sealing linear bushing - A floating seal for self-aligning linear bushing
5 Outer Sleeve	- POM	- Support ball plate - Possible to run with highspeed and reduce the inertia force & noise because of low friction with lightweight

● Linear Bushing

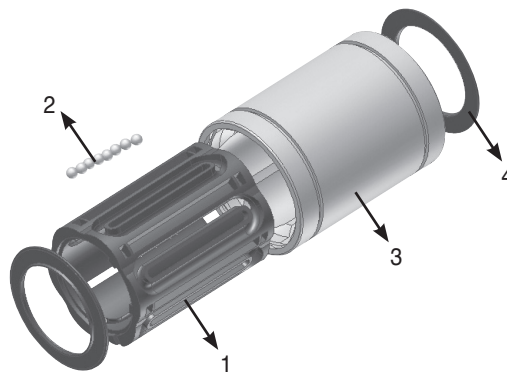

Part	Material	Special features and function
1 Retainer	- POM - Stainless Steel	- Guide ball's Motion - An essential element of unlimited linear stroke
2 Ball	-Standard(High Carbon Chromium Bearing Steel Ball) - Stainless steel - Ceramic	- the support of the load by direct contact between shaft and ball plate - An essential element for low friction, high load capacity, high precision and high speed stroke
3 Outer Sleeve	- High carbon bearing steel - Stainless steel * available Corrosion resistance plating	- Direct contact with the ball to the load - Direct contact housing - An essential element for high load capacity - Interchangeability
4 Rubber Seal	- NBR * optional item	- Preventing a foreign substance from outside - Preventing outflow of lubricant by sealing linear bushing

Do you need a solution?
We can provide you with a solution!



SAMICK Linear Bushing

SAMICK LINEAR BUSHING

SAMICK Linear Bushing, LM type is the linear motion system with unlimited stroke by applying with LM shaft. Because of the point contact between Balls and LM shaft, minimum friction can be acquired and that can give you the high precision motion. SAMICK Linear Bushing serves the aligned balls toward the LM Shaft by the single Retainer and cylindrical shape of Raceway. Outer Sleeve is made of high-carbon Chromium Bearing Steel, and inner and outer grinding processes are applied after Heat treatment.

Interchangeability

The Dimensions of SAMICK Linear Bushing are standardized to have full interchangeability. LM shaft is provided with the cylindrical grinding to have high precision fitting clearance.

Rigid Outer Sleeve

Hardened and Precisely ground Outer Sleeve is made of Bearing steel, and can be direct assembled with the needle bearing on outer surface.

High precision Retainer

The single body retainer guides 4~6 ball circuits, and it makes the precision guiding against the balls moving direction and smooth motion.

LM Case Unit

LM Case Unit, SC type is consist of the light Aluminum case and LM type Linear Bushing, so the assembly can be finished by simple bolting. Longer life can be obtained by adjusting the Ball circuit orientation of Linear Bushing against the direction of load.

Application

SAMICK Linear Bushing are widely used in Precision equipments; Computer and peripheral equipments, Measuring equipments, Auto recording equipments, and 3D measuring equipments, and Linear Motion systems in Machine for Mass Production; Multi-Axis Drilling machines, Punching Press, Tool Grinders, Auto-Gas cutters, printing machines, card selectors, food packing machines, and etc.

Structure

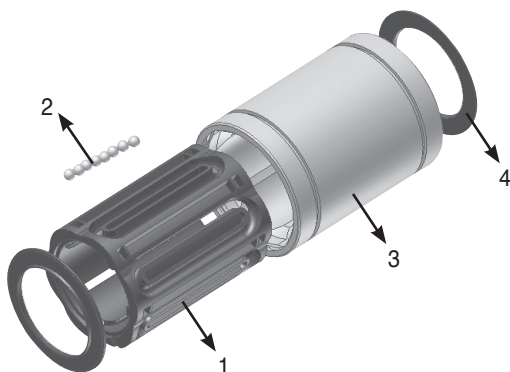

part	Material
1 Retainer	- POM - Stainless Steel
2 Ball	-Standard(High Carbon Chromium Bearing Steel Ball) - Stainless steel - Ceramic
3 Outer-sleeve	- High carbon bearing steel * Corrosion resistance plating available
4 Seal	- NBR (Nitrile Butadiene Rubber) * Optional



Part Number Notation

● Linear Bushing

LM E F P 20 L UU OP - A N S

● SAMICK Linear Bushing
● Standard Option(Europe, US)
Blank Asian Standard
E European Standard
● Flange Option
Blank Standard
F Circular type
K Square type
H Oval type
● Flange Location
Blank Standard
P Pilot
M Middle
● Nominal Shaft Diameter
5~80mm Standard
6~80mm Flange
● Length
Blank Standard
L Long
● Seal
Blank No Seal
UU Both Side Seal
U One Side Seal
● Sloting Type
Blank Standard type
OP Open type(for support rail)
AJ Adjustable type
● Retainer (material)
Blank Resin Retainer(Standard)
A Steel Retainer(High temperature) ^{★1}
● Outer-sleeves (by corrosion resistance)
Blank Resin retainer(Standard)
N Electroless nickel plating
R Raydent treatment
● Ball type (material)
Blank Standard(High Carbon Chromium Bearing Steel Ball)
S Stainless steel ball

★1 Steel retainer 06mm to 30mm only (LM08S Resin retainer only)

Load rating and Nominal Life

The Load rating of SAMICK Linear Bushing can be affected by the balls orientation against the Load. The Basic Load rating in the table is the Load rating of Linear Bushing when 1 (one) Ball circuit are just beneath the load. As shown in Table, If the Ball are located on symmetrical position against the Load, the Load rating will be increased and the travel life will be extended.

Load ratings and Orientation of Balls

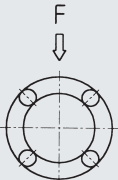
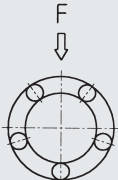
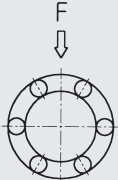
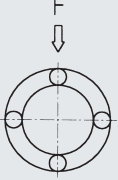
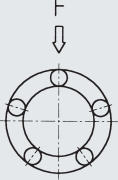
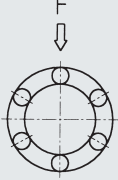
No. of Ball Row	Orientation of Balls		
	4 Row	5 Row	6 Row
Max. Load			
Equation	$F = 1.41 \times C$	$F = 1.46 \times C$	$F = 1.28 \times C$
Min. Load			
Equation	$F = C$	$F = C$	$F = C$

Nominal life

The travel life of a Linear Bushing is determined largely by the quality of the shaft. The Basic Dynamic load rating is maximum continuous load that can be applied to the Linear Bushing with 90% of reliability achieving after 50km traveling under normal conditions. The nominal travel life can be calculated by follow equation.

$$L_{10} = \left[\frac{C}{P} \right]^3 \times 50$$

- L_{10} : Nominal life (unit: km)
- C : Basic dynamic load rating (unit: N)
- P : Calculated load (N)

Practically, other factors (Hardness factor, Load factor, Contact factor, etc) will affect the life as follows.

$$L_{10} = \left[\frac{f_H \times f_T \times f_C}{f_w} \times \frac{C}{P} \right]^3 \times 50$$

- f_w : Load factor
- f_H : Hardness factor
- f_T : Temperature factor
- f_C : Contact factor

Contact use of Linear Bushing and Travel life

In case of moment load applied and contact use with one or two Linear Bushing, equivalent standard load must be calculated.

$$P_U \cong K \times M$$

P_U : Equivalent radial load (N)
 (load by moment load)
 K : Equivalent coefficient (see Table 6)
 M : Moment (N·mm)

From the above equation, the stroke and frequency are constant, the Travel Life can be calculated by following equation.

$$L_h = \frac{L \times 10^6}{2 \times l_s \times N_l \times 60}$$

L_h : Travel life (hr)
 l_s : Stroke (mm)
 N_l : Number of strokes per minute (cpm)

Table 6. Linear Bushing Equivalent coefficient

Equivalent coefficient (K)							
P/N	1EA	2EA	P/N	1EA	P/N	1개	2EA
LM 05	1.253	0.178	LM 05L	0.223	LME 05	0.669	0.123
LM 06	0.553	0.162	LM 06L	0.201	LME 08	0.514	0.116
LM 08S	0.708	0.166	LM 08L	0.151	LME 12	0.389	0.090
LM 08	0.442	0.128	LM 10L	0.118	LME 16	0.343	0.081
LM 10	0.389	0.101	LM 12L	0.113	LME 20	0.291	0.063
LM 12	0.389	0.097	LM 13L	0.107	LME 25	0.209	0.052
LM 13	0.343	0.093	LM 16L	0.096	LME 30	0.167	0.045
LM 16	0.279	0.084	LM 20L	0.082	LME 40	0.127	0.039
LM 20	0.257	0.071	LM 25L	0.060	LME 50	0.105	0.031
LM 25	0.163	0.054	LM 30L	0.053	LME 60	0.093	0.024
LM 30	0.153	0.049	LM 35L	0.050			
LM 35	0.143	0.045	LM 40L	0.043			
LM 40	0.117	0.040	LM 50L	0.034			
LM 50	0.096	0.032	LM 60L	0.031			
LM 60	0.093	0.028					

★1 Equivalent coefficient of LMF/K/H, LMFP/KP/HP, SC type is same as LM type

★2 Equivalent coefficient of LMF/K/H-L, LMFP/KP/HP-L, LMFM/KM/HM type is same as LM-L type

★3 Equivalent coefficient of LMEF/K/H, SCE type is same as LME type

Short stroke Applications

In applications when the stroke is short, the life of the shaft is shorter than that of the Linear Bushing. In short stroke applications, the required dynamic load rating must be multiplied by the shot stroke correction factor found on Fig right side.

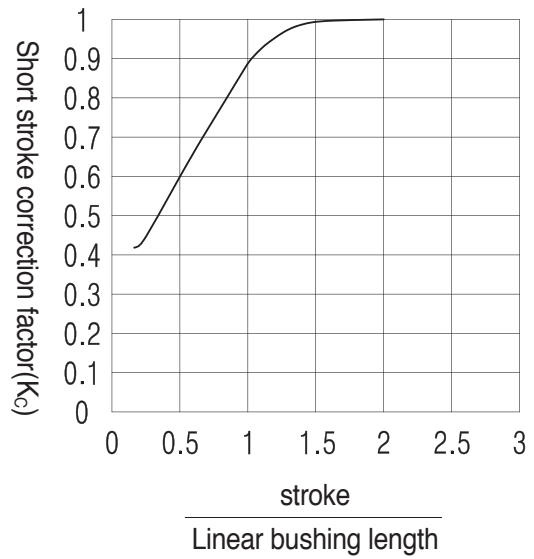

Fig 5. Short stroke correction factor(Kc)

Lubrication and Friction

Linear Bushing is used with grease lubrication or oil lubrication but in some case, it is used without any lubrication.

Grease Lubrication

Before applying the grease, the anticorrosive oil must be removed by kerosene or organic solvent, and applying the grease after drying. Must Applying grease directly on the ball for both side sealed type (UU), and applying same as above or applying on the shaft for without sealed type. Lithium soap radical of viscosity mark (JIS No. 2) is recommended for use.

Oil Lubrication

Operating Temperature	Viscosity
-30°C ~ 50°C	VG 15 ~ 46
50°C ~ 80°C	VG 46 ~ 100

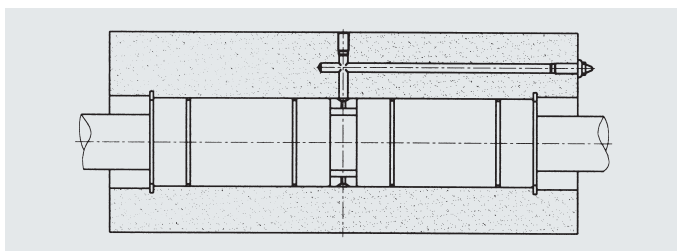

Fig 6

There is no need to remove anticorrosive oil when oil is used for lubrication. ISO viscosity grade VG15~100 oil is usually used according to the temperature. The turbine oil, machine oil, and spindle oil are usually used as lubrication oil.

Drop the oil on the shaft for lubrication, or supply it through an oil hole provided on the housing (Fig 6). However, dropping lubrication is not used in both seal type because the seal remove oil, because. Contact SAMICK for Linear Bushing with lubrication hole for user's demands

Coefficient of Friction

Linear Bushing has balls as rolling elements, so it gives rise to reduces the frictional resistance. Static friction in particular is very low, and there is just little difference between static and dynamic friction, so, that stick-slip does not occur. Such low friction makes High precision feeding possible. The normal friction coefficient is on Fig below, and the Friction resistance can be calculated by following equation

$$F = \mu \cdot P + f_s$$

- F : Friction resistance force
- f_s : Resistant of Seal (0.3 ~ 2.4N)
- P : Applied External load(Perpendicular Load against shaft core)(N)
- μ : Friction Coefficient(Static or Dynamic)

Friction coefficient of linear bushing

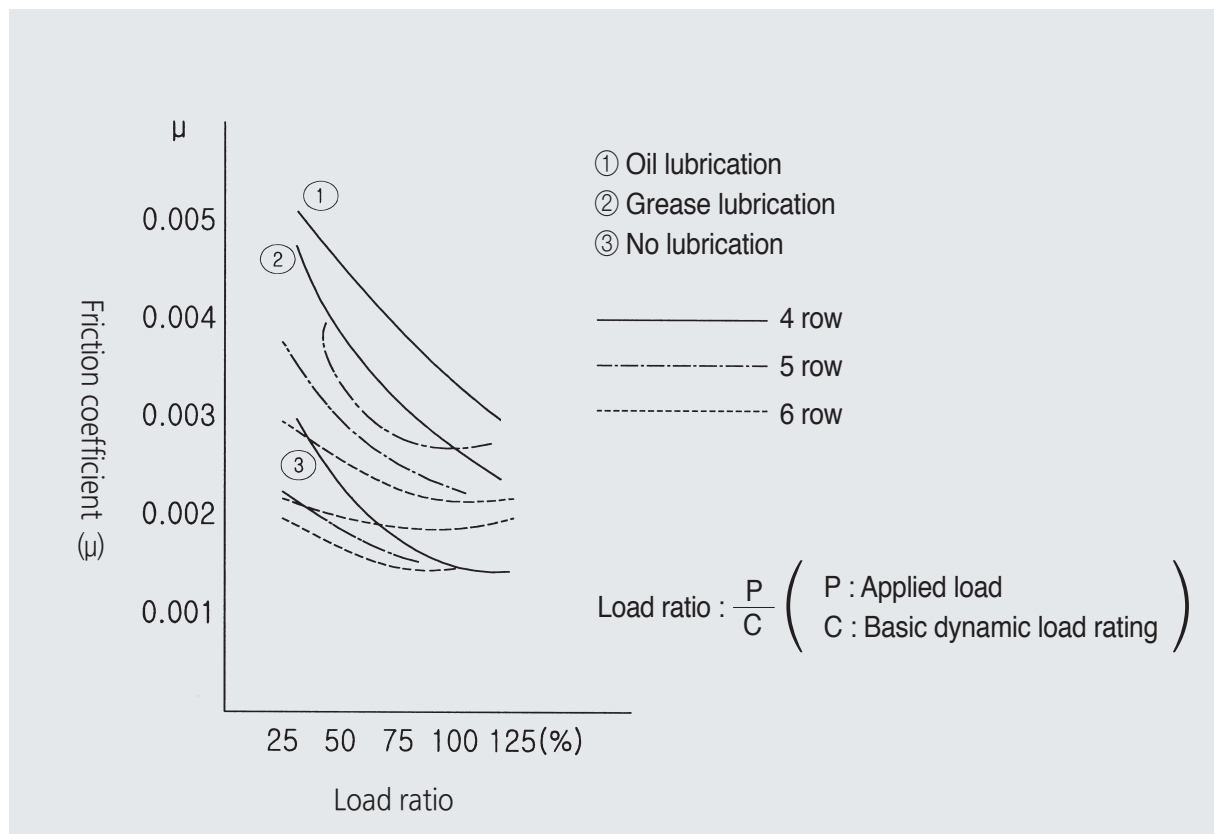

Fig 7. Friction coefficient of linear bushing

Installation Guide

Tolerance of Housing bore

Recommended Tolerance of Housing bore for SAMICK Linear Bushing are in Table7. Normal fit is standard, but for without clearance, pressed fit is also available.

Table7. The bore clearance of Housing

Type		Case	
Part number	Grade	Normal fit	Pressed fit
LM	Higher(H)	H7	J7
LME	-	H7	K6, J6
LMF / FP LMK / KP LMH / HP LM_L LMF / FP_L LMK / KP_L LMH / HP_L LMFM	-	H7	J7

Clearance of Outer sleeve and Shaft

Normal fit is standard for using of Linear Bushing with LM shaft. And, for without clearance, tight fit is available. Table8. shows outer diameter tolerance of shaft.

Table8. Outer diameter tolerance of shaft

Type		LM Shaft	
Part number	Grade	Normal fit	Pressed fit
LM	Higher(H)	f6, g6	h6
LME	-	h6	k6
LMF / FP LMK / KP LMH / HP LM_L LMF / FP_L LMK / KP_L LMH / HP_L LMFM	-	f6, g6	h6

Negative diametric clearance should not exceed what is specified in the dimension table.

Radial Clearance (μ)																
Dr. Type	5	6	8S	8	10	12	13	16	20	25	30	35	40	50	60	80
LM(μm)	-3	-5	-5	-5	-5	-5	-7	-7	-9	-9	-9	-13	-13	-13	-16	-20
LME(μm)	-5			-5		-7		-7	-9	-9	-9		-13	-13	-16	

Mounting

High holding strength toward LM shaft direction is not required, but just press fit only for mounting is not recommended.

Standard type

Feasible mounting methods are illustrated in Fig 8 and Fig 9. At this moment, fix the linear bushing with retaining rings or cover plates.

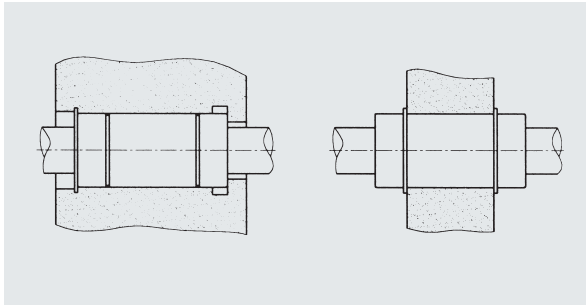

Fig 8. Mounting with retaining rings

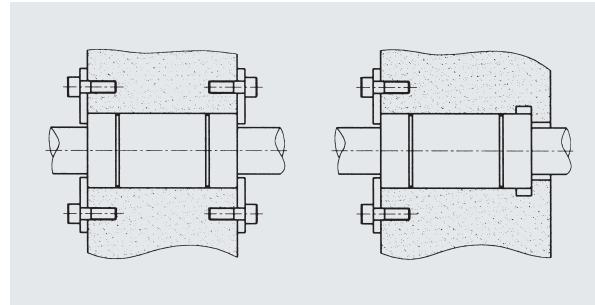

Fig 9. Mounting with cover plates

Retaining ring for Mounting

Retaining ring for LM type SAMICK Linear Bushing are used for mounting as shown is the table below.

Table9. Retaining ring dimension

Part number	Retaining ring(mm)			
	External (for Shaft)		Internal (for Bore)	
	C type	Needle type	C type	Needle type
LM 05	10	10	10	10
LM 06	12	12	12	12
LM 08	-	15	15	15
LM 08S	-	15	15	15
LM 10	19	19	19	19
LM 12	21	21	21	21
LM 13	23	23	23	23
LM 16	28	28	28	28
LM 20	32	32	32	32
LM 25	40	40	40	40
LM 30	45	45	45	45
LM 35	52	52	52	52
LM 40	60	60	60	60
LM 50	80	80	80	80
LM 60	90	90	90	90
LM 80	120	120	120	120

★ the information in the table is common for LM and LM-L type

Setscrew mounting prohibited

Mounting a Linear Bushing with a set screw as show in Fig10 will cause deformation of the outer sleeve and should be avoided.

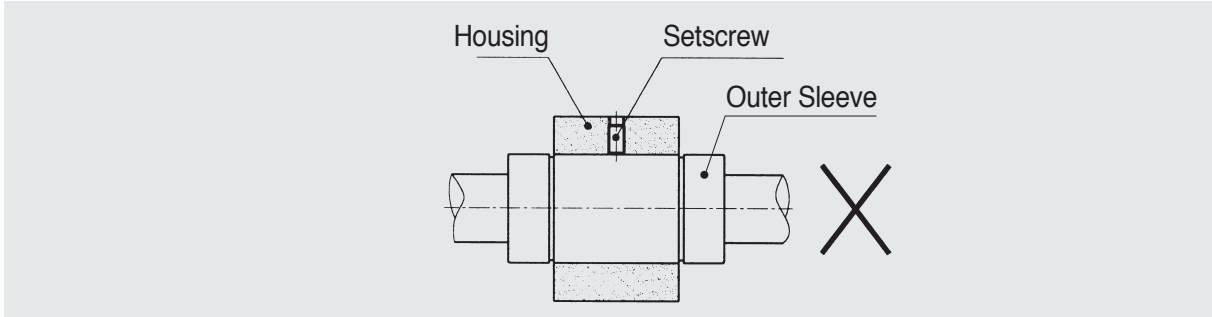

Fig 10. Mounting with setscrew

Flanged type

Mounting for LMF, LMK, LMH (including long type), only mounting the flange with mounting bolt can be all of mounting because of its single body shape. Geometric Dimensional Tolerance should be considered when the Outer Sleeve is the datum for installation.

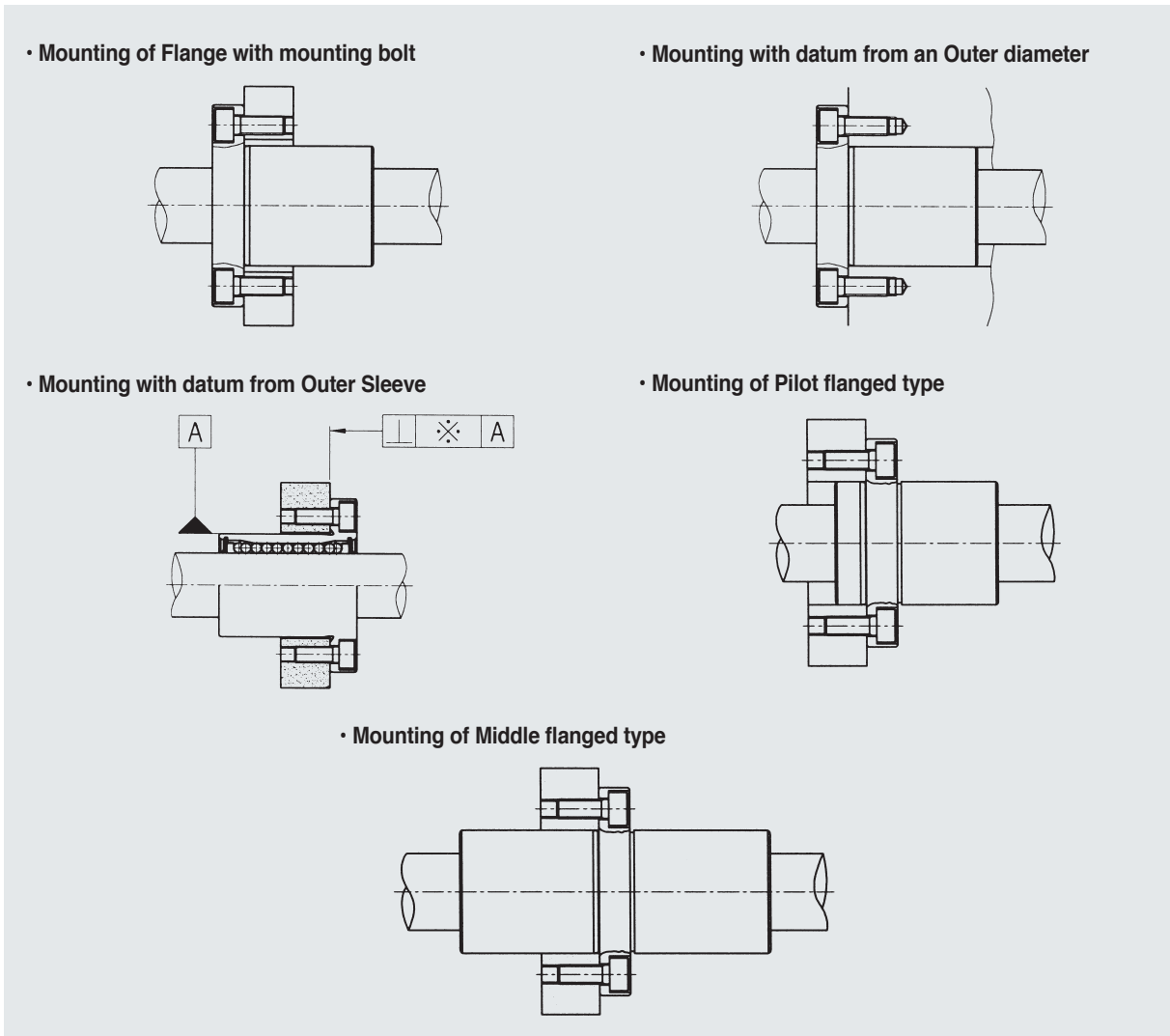

Fig 11. Flanged type mounting

Mounting of Adjustable type

Adjustment of clearance for Adjustable type (AJ) and LM shaft can be obtained by assembling with the adjustable type Housing. In this case, the slotted side of Linear Bushing should be located at 90° of open side of Housing for equivalent deformation against radial direction..

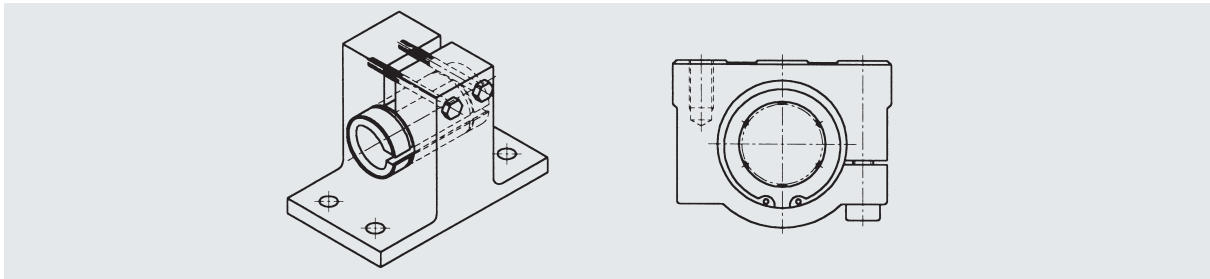

Fig 12. Mounting of adjustable type

Mounting of Housing

SAMICK Linear Bushing provides smooth movement designed with minimum frictional resistance. The advantage will not be effective without careful installation.

The most important thing is parallelization between Linear Bushing's alignment and LM shaft. Generally, two Linear Bushings are used at each LM shaft for smooth movement. Housing should be mounted by adjusting carefully as below.(Fig13) The process is unnecessary in case of SCW TYPE with two Linear Bushings. Also, the distance between housing's datum and LM shaft should keep parallel under 0.025mm. Inserting Feeler gauge along the plane of housing where the bolt is fastened, It can be fastened with precise adjustment. Housing should be carefully mounted with parallelization as below.(Fig14)

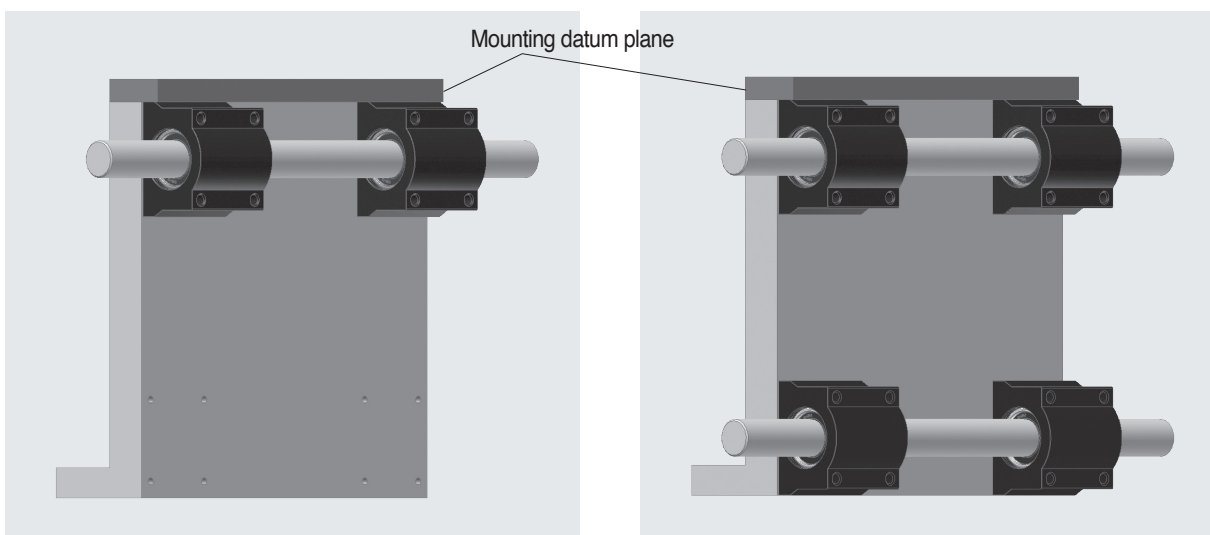

Fig 13.

Fig 14.

- 1) Install the mounting datum plane by setting the step pulley or assembly of a vertical support
- 2) Mount two housings cleavingly by the mounting datum plane.
- 3) Mount another pair of housings and fasten bolts at the opposite plane of Table.
- 4) Insert LM shaft with h6 or g6 of precise diameter and measure the distance between vertical support as 2) and LM shaft
- 5) Operate Table after fixing LM shaft and check the aligning
- 6) Fasten bolts which for fix Table and housing after adjustment aligning of two pair of housing.

LM shaft and rail installation

Install LM shaft and rail with the Table after mounting of housing to the attachment surface. the parallelization of LM shaft under the stroke should be installed under 0.025mm for smooth movement. Following instruction is for LM shaft installation.

- 1) Place a LM shaft(end supporting or whole supporting)on the floor surface and fasten bolts
- 2) Fasten bolts to the right position while measuring straightness of aligning shaft with laser, auto collimator or other optical instruments.
- 3) Put LM shaft on the right place and fasten bolts after fixing the first LM shaft
- 4) When finishing temporary installation of LM shaft, combine Table and operate in the stroke. parallelize the first and the second LM shaft.
- 5) In case of whole supporting system, Table should be close to bolting place and fastened with bolts. move a pallet to the end line of LM shaft and fix bolts.
- 6) Additionally, it is possible to check whether the datum plane of Table's edge is moving in parallel as below. At this moment, the figure of indicator adjoining with the datum plane of Table's edge should not be changed.

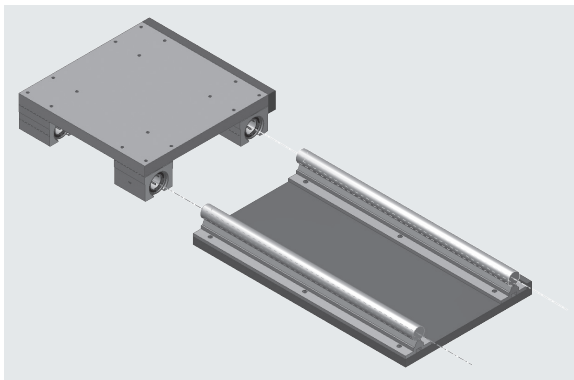

Fig 15.

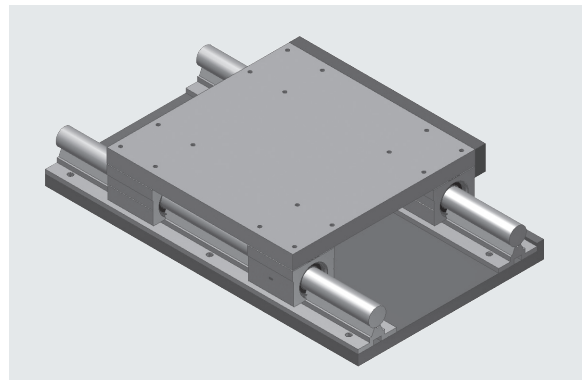

Fig 16.

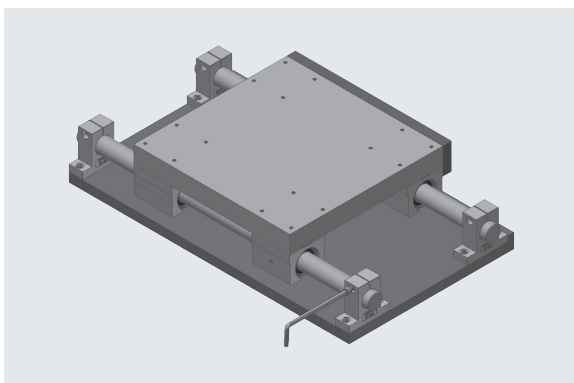

Fig 17.

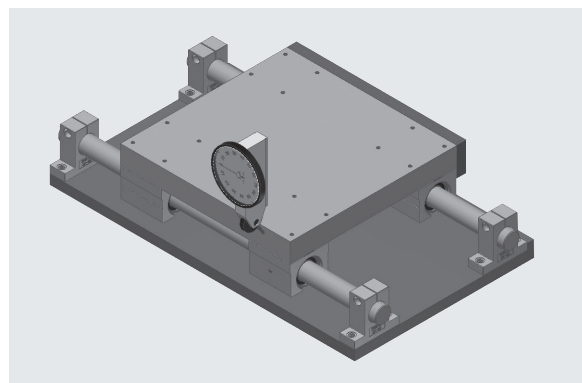

Fig 18.

Mounting of open type

Open type(OP) also can be used with clearance adjustable housing as shown on Figure. Light pre-load is applied for normal using, but heavy pre-load should be avoided.

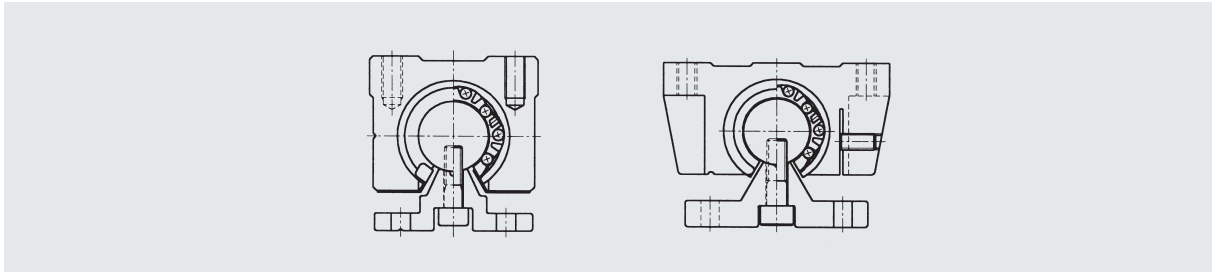

Fig 19. Mounting of Open type

Variation of static load ratings according to installation of Linear Bushing open type

No. of Ball Rows	Orientation of Balls		
	3 row	4 row	5 row
Max. Load			
Equation	$F = C$	$F = C$	$F = C$
Min. Load			
Equation	★ $F = 0.64 \times C$	$F = 0.54 \times C$	$F = 0.57 \times C$

★ not recommended

Mounting of Shaft Support

Shaft support, SK can be mounted with mounting bolt for table, and LM shaft can be mounted with tightening bolt.

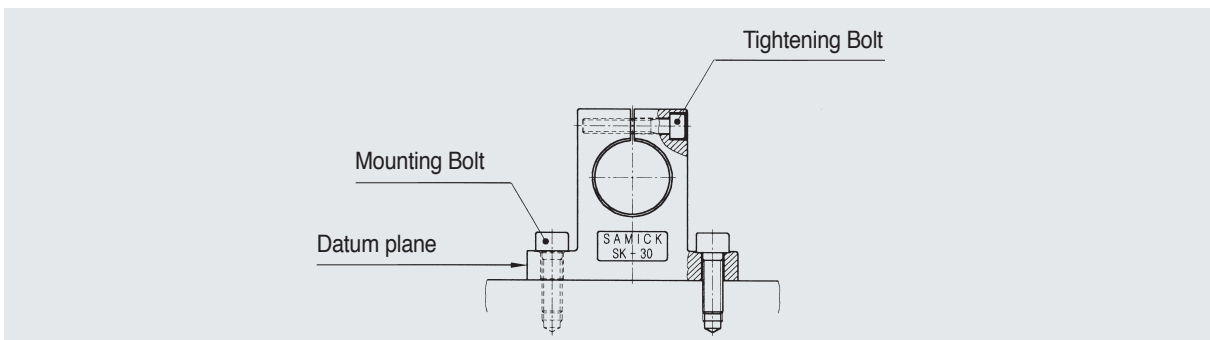

Fig 20. Mounting of Shaft support

Mounting of LM Aluminum Case Unit

Mounting of SC type Both side mounting of SC(E), SC(E)_W, SC(E)_V type from the top and the bottom side with mounting bolt are both available, and it gives you minimum mounting time.

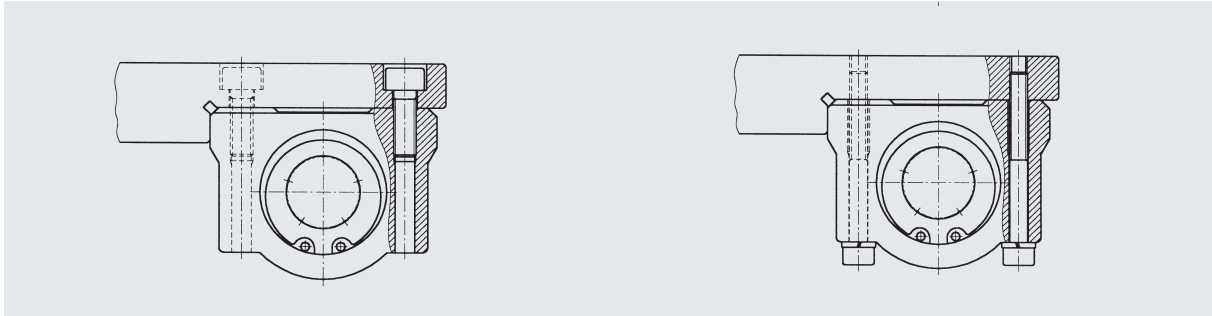

Fig 21. Mounting of Case Unit

Application Tips

Mounting of Linear Bushing

For mounting of standard type SAMICK Linear Bushing into the Housing, a jig should be used to avoid direct hitting on the outer sleeve or seal when installing. See below. Fig 22.

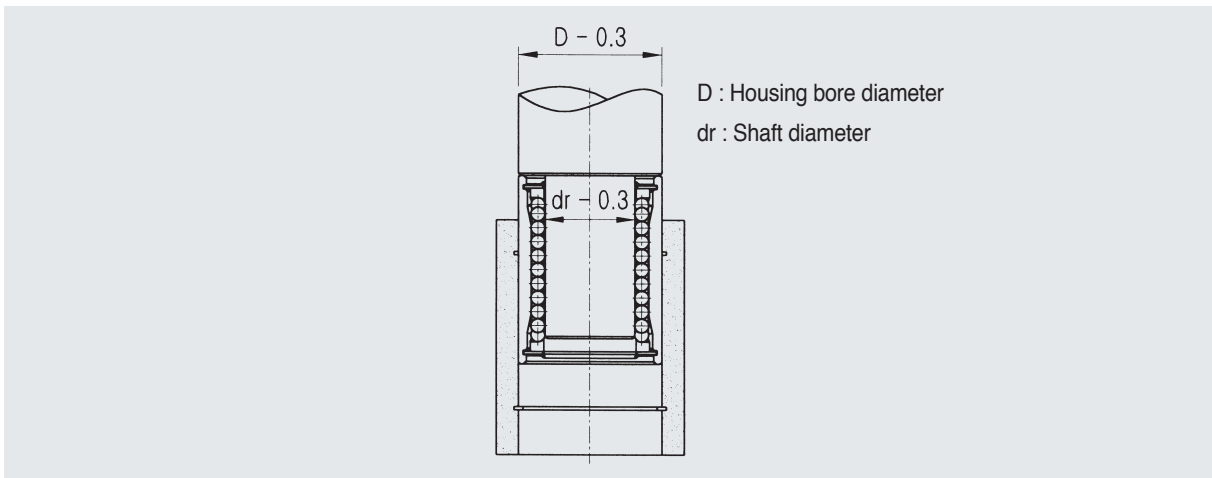

Fig 22. Example of Linear Bushing and Housing assembly

Insertion of Shaft

Care must be taken to align the bushing and the shaft when inserting a shaft into a linear bushing. If the shaft is inserted with slanted, balls may depart from the damaged or deformed retainer.

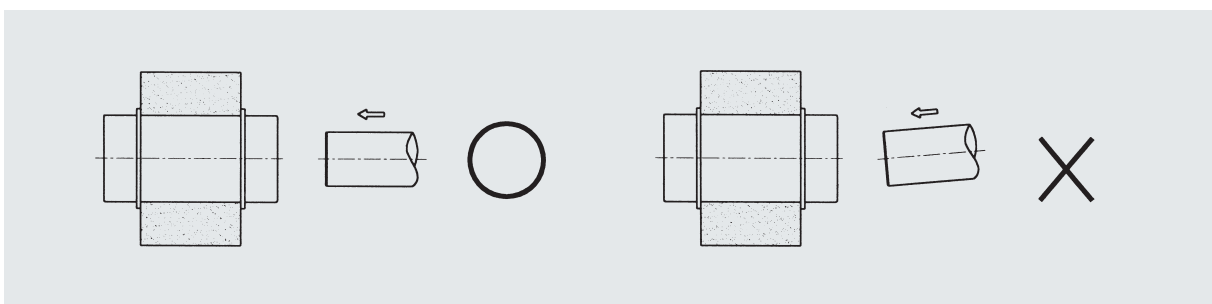

Fig 23. Insertion of shaft into Linear Bushing

When Moment loads applied

External loads should be distributed uniformly on a Linear Bushing. When moment loads are applied, two or more Linear Bushings should be used on one LM shaft, and the distance between two Linear Bushings should have enough distance. When the moment loads are applied, calculate the equivalent load and choose the proper Linear Bushing.

Mounting of open type Linear Bushing with three ball rows

Please mount the open type Linear Bushings with three ball circuit as same as Fig 24 for considering of load distribution.

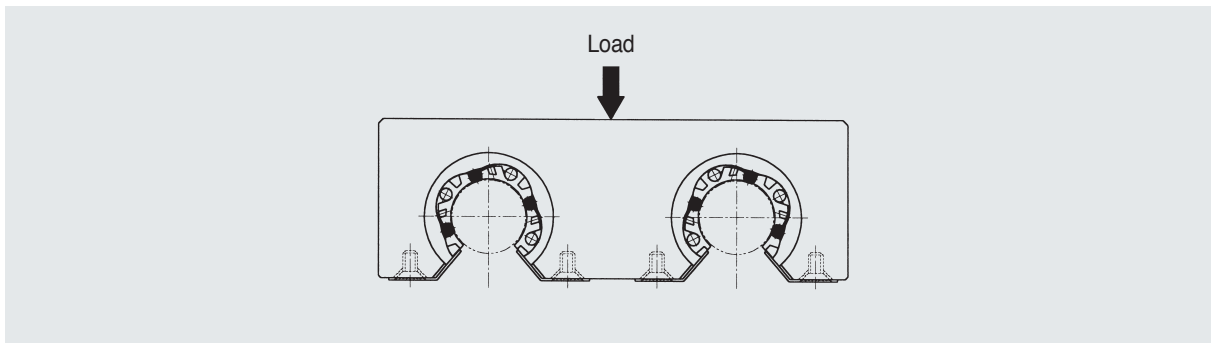

Fig 24. Installation example of LM12, LM13

The Rotational Motion Prohibited

Linear Bushing is not suitable for rotational motion, If the Linear Bushing is exposed to rotational motion it may lead unexpected accidents.

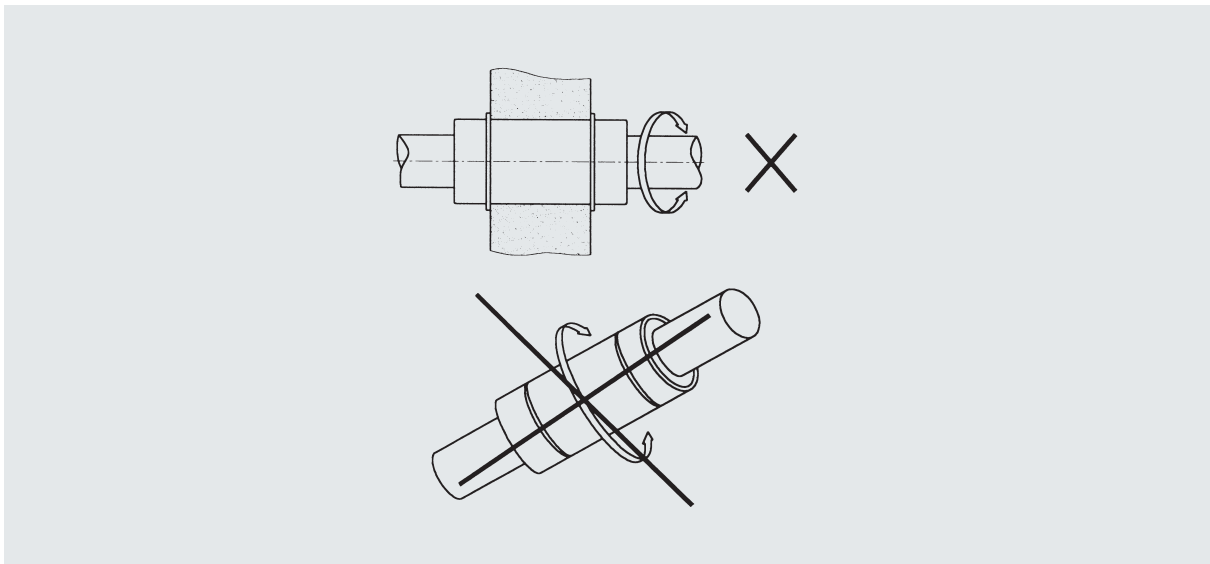

Fig 25. The Rotational Motion Prohibited

Overall Linear Bushing technology by SAMICK

Look at the technology here,
and feel the Instinct of Linear Art at the field.



Technical Information

Load Rating and Service Life of Linear Motion System

When determine a model that would best suit for service conditions of a linear motion system, the load rating and travel life of the model must be considered. To consider the load rating, you should know the static safety factor of the model, which is calculated based on the basic static load rating. The service life can be assessed by calculating the nominal life, based on the basic dynamic load rating, and you need to check if the values thus obtained meet your requirements.

Basic static load rating

There are two basic load ratings of a linear motion system: basic static load rating (C_0), which sets the static load allowance limit, and basic dynamic load rating(C), which is using for calculating travel life.

Basic Static Load Rating (C_0)

If a linear motion system, whether at rest or in motion, receives an excessive load or large impact, a local permanent deformation develops the raceway and rolling elements. And if the magnitude of the permanent deformation exceeds a certain limit, it hinders the smooth motion of the linear motion system. The basic static load rating refers to a static load in a given direction with given magnitude, which total permanent deformation of rolling elements and raceway at the contact area is approximately 0.0001 times of the rolling element diameter. In a linear motion system, the basic static load rating is defined as the radial load. Thus, the limit of static load allowance is the basic static load rating. For the rating values of individual linear motion systems, see the respective specification table in this catalog.

Static Safety Factor (f_s)

A linear motion system may possibly receive an unpredictable external force due to the vibration or impact while it is at rest or in motion, or inertia as a result of starting and stopping. It is, therefore, necessary to consider the static safety factor against operating loads. The static safety factor(f_s) indicates the ratio of a linear motion system load carrying capacity (basic static load rating, C_0) to the load exerted there on. To calculate a load exerted on the linear motion system, the mean load for calculating the service life and the maximum load for calculating the static safety factor must be obtained in advance. A system can receive unexpected excessive load when it is subject to frequent starts and stops, placed under machining loads, or when the severe moment is applied by overhanging loads. When selecting the correct type of a linear motion system for your application, be sure that the type you are considering can bear the maximum possible load when stopped and in operation. The table below specifies the standard values for the static safety factors.

$f_s = \frac{C_0}{P}$ 또는 $f_s = \frac{M_0}{M}$	<p>f_s : Static safety factor</p> <p>C_0 : Basic static load rating (N)</p> <p>M_0 : Static permissible moment (N·mm)</p> <p>P : Calculated load (N)</p> <p>M : Calculated moment (N·mm)</p>
--	---

To calculate a load exerted on the linear motion system, the mean load for calculating the service life and the maximum load for calculating the static safety factor must be obtained in advance. A system can receive unexpected excessive load when it is subject to frequent starts and stops, placed under machining loads, or when the severe Moment load is applied by overhanging loads. When selecting the correct type of a linear motion system for your application, be sure that the type you are considering can bear the maximum possible load when stopped and in operation. The table 1. below specifies the standard values for the static safety factors.

Table1. Static Safety Factor(f_s)

Machine used	Loading conditions	f_s lower limit
Ordinary Industrial Machine	Receives no vibration or impact	1.0 ~ 1.3
	Receives vibration or impact	2.0 ~ 3.0
Machine tool	Receives no vibration or impact	1.0 ~ 1.5
	Receives vibration or impact	2.5 ~ 7.0

For large radial loads	$\frac{f_H \cdot f_T \cdot f_C \cdot C_0}{P} \geq f_s$	
C_0 : Basic static load rating (N)	P : Calculated load (N)	f_H : Hardness factor
f_T : Temperature factor	f_C : Contact factor	

Basic Dynamic Load Rating(C)

The basic dynamic load rating (C) refers to a load in a given direction with given magnitude such that when identical linear motion systems in a group are interlocked with one another under the same conditions, the nominal life (L) of the systems is 50km (L=50km) if the systems use balls, and 100km(L=100km) if they use rollers. The basic dynamic load rating (C) is used to calculate the service life of a set of linear motion systems, which are interlocked with one another in response to a load. For rating values of individual linear motion systems, see the respective specification tables in this catalog.

Nominal Life(L₁₀)

The service lives of linear motion systems more or less vary from system to system even if they are manufactured to the same specifications and remain in service under the same operating conditions. Hence a guideline for determining the service life of a linear motion system is given based on nominal life, Which is defined as follows. The nominal life refers to the total running distance that 90% of identical linear motion systems in a group, when interlocked with one another under the same conditions, can achieve without flaking develops. The nominal life (L) of a linear motion system can be obtained from the basic dynamic load rating (C)and load imposed (P) using the following equations.

We take into account whether the basic dynamic load rating(L10) is defined based on 50km or 100km by the standard of ISO14728-1.

For linear motion system with balls

$$L_{10} = \left[\frac{C}{P} \right]^3 \times 50$$

$$\ast C_{100} = \frac{C_{50}}{1.26}$$

L_{10} : Nominal life of (km)
 C : Basic dynamic load rating (N)
 P : Calculated load
 C_{50} : Basic dynamic load rating based on a nominal life of 50km
 C_{100} : Basic dynamic load rating based on a nominal life of 100km

\ast Conversion of dynamic load rating based on ISO 14728-1

For a linear motion system with rollers

$$L_{10} = \left[\frac{C}{P} \right]^{\frac{10}{3}} \times 100$$

$$\ast C_{100} = \frac{C_{50}}{1.23}$$

\ast Conversion of dynamic load rating based on ISO 14728-1

The travel life of the Linear Bushing can be obtained using the following equation

$L_{10} = \left(\frac{f_H \times f_T \times f_C}{f_W} \times \frac{C}{P} \right)^3 \times 50$	<p>L : Nominal life of 50km</p> <p>C : Basic dynamic load rating of 50km</p> <p>P : Applied load</p>	<p>f_H : Hardness factor (see Fig 1)</p> <p>f_C : Contact factor (See fig3)</p> <p>f_T : Temperature factor (see Fig 2)</p> <p>f_W : Load factor (see Table)</p>
--	--	--

Once nominal life L is obtained using this equation, the Linear Bushing service life can be calculated using the following equation, if the stroke length and the number of reciprocating cycles are constant

$L_h = \frac{L \times 10^6}{2 \times l_s \times N_l \times 60}$	<p>L_h : Travel life in hours</p> <p>N_l : Number of strokes per minute(cpm)</p>	<p>l_s : Stroke(mm)</p>
---	--	--------------------------------------

Factors that affect the travel life

Hardness factor(f_H)

To ensure achievement of the optimum load rating of the Linear Bushing, the raceway hardness must be HRC 58 to 64. At Hardness below this range, the basic dynamic and static load ratings decrease. The ratings must therefore be multiplied by the respective hardness factors (f_H).

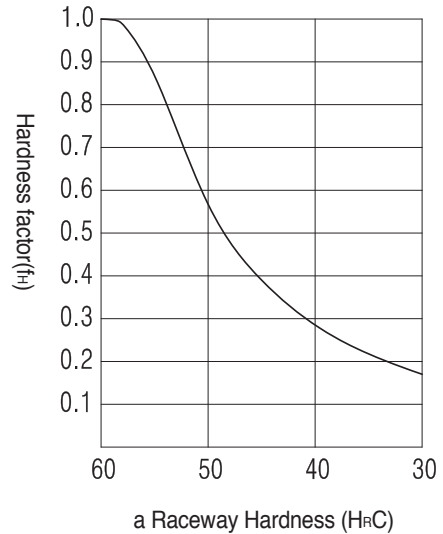

Fig1 Hardness factor (f_H)

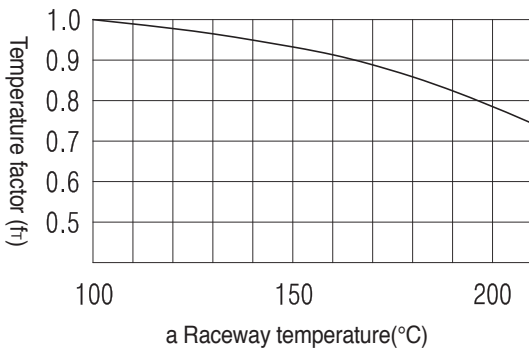

Fig2 Temperature factor (f_T)

Temperature factor(f_T)

For Linear Bushings used at ambient temperatures over 100°C, a temperature factor corresponding to the ambient temperature, selected from the diagram, must be taken into consideration. For higher than 80°C application, the seals, end plates, and retainer must be changed for high temperature specifications. (Temperature range: -20°C ~ 80°C) In addition, please note that the selected Linear Bushing itself must be a model with high temperature specifications.

Contact factor(f_c)

When multiple Linear Bushings are used laid over one another, moments and mounting-surface precision will affect operation, making it difficult to achieve uniform load distribution. For Linear Bushings used laid over one another, multiply the basic load rating (C or C_0) by a contact factor selected from the table below.

Table2. Contact factor(f_c)

Number of linear bushings on a shaft	Contact factor(f_c)
2	0.81
3	0.72
4	0.66
5	0.61
Over 6	0.60
In normal use	1.0

Load factor(f_w)

In general, machines in reciprocal motion are likely to cause vibration and impact during operation, and it is particularly difficult to determine the magnitude of vibration that develops during high-speed operation, as well as that of impact during repeated starting and stopping in normal use. Therefore, where the effects of speed and vibration are estimated to be significant, divide the basic dynamic load rating (C) by a load factor selected from the table below.

Table3. Load factor(f_w)

Operating conditions		Load factor (f_w)
Load conditions	Speed	
No impact and vibration	Under 15m/min	1.0~1.5
Sight impact and vibration	Under 60m/min	1.5~2.0
Considerable impact and vibration	Over 60m/min	2.0~4.0

Load Consideration

When designing a linear motion system, it is necessary to consider how the variables of operation will affect performance. The following examples demonstrate how the position of the load and the center of gravity can influence the product selection. When evaluating your application, review each of the forces acting on your system and determine the product best for your needs.

Horizontal Application | At the time of movement with uniform velocity or at the time of stop

$$F_{1Z} = \frac{W}{4} + \left(\frac{W}{2} \cdot \frac{d_2}{d_0} \right) - \left(\frac{W}{2} \cdot \frac{d_3}{d_1} \right)$$

$$F_{2Z} = \frac{W}{4} - \left(\frac{W}{2} \cdot \frac{d_2}{d_0} \right) - \left(\frac{W}{2} \cdot \frac{d_3}{d_1} \right)$$

$$F_{3Z} = \frac{W}{4} - \left(\frac{W}{2} \cdot \frac{d_2}{d_0} \right) + \left(\frac{W}{2} \cdot \frac{d_3}{d_1} \right)$$

$$F_{4Z} = \frac{W}{4} + \left(\frac{W}{2} \cdot \frac{d_2}{d_0} \right) + \left(\frac{W}{2} \cdot \frac{d_3}{d_1} \right)$$

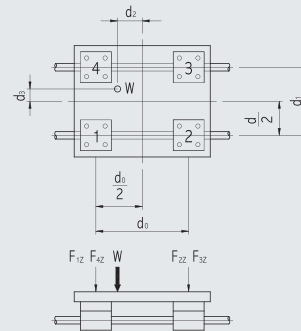

Horizontal Application | At the time of movement with uniform velocity or at the time of stop

$$F_{1Z} = \frac{W}{4} + \left(\frac{W}{2} \cdot \frac{d_2}{d_0} \right) - \left(\frac{W}{2} \cdot \frac{d_3}{d_1} \right)$$

$$F_{2Z} = \frac{W}{4} - \left(\frac{W}{2} \cdot \frac{d_2}{d_0} \right) - \left(\frac{W}{2} \cdot \frac{d_3}{d_1} \right)$$

$$F_{3Z} = \frac{W}{4} - \left(\frac{W}{2} \cdot \frac{d_2}{d_0} \right) + \left(\frac{W}{2} \cdot \frac{d_3}{d_1} \right)$$

$$F_{4Z} = \frac{W}{4} + \left(\frac{W}{2} \cdot \frac{d_2}{d_0} \right) + \left(\frac{W}{2} \cdot \frac{d_3}{d_1} \right)$$

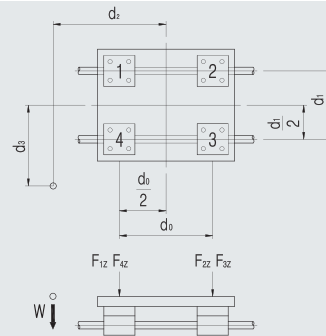

Side Mounted Application | At the time of movement with uniform velocity or at the time of stop

$$F_{1Y} \sim F_{4Y} = \left(\frac{W}{2} \cdot \frac{d_3}{d_0} \right)$$

$$F_{1Z} = F_{4Z} = \frac{W}{4} + \left(\frac{W}{2} \cdot \frac{d_2}{d_0} \right)$$

$$F_{2Z} = F_{3Z} = \frac{W}{4} - \left(\frac{W}{2} \cdot \frac{d_2}{d_0} \right)$$

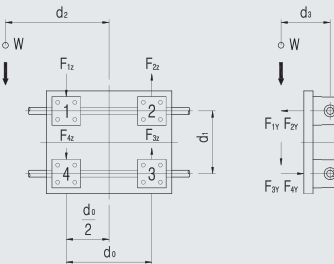

Vertical Application | At the time of movement with uniform velocity or at the time of stop At the time of start and stop, the load varies because of inertia

$$F_{1X} \sim F_{4X} = \left(\frac{W}{2} \cdot \frac{d_2}{d_0} \right)$$

$$F_{1Y} \sim F_{4Y} = \left(\frac{W}{2} \cdot \frac{d_3}{d_0} \right)$$

$$F_{1X} + F_{4X} \sim F_{2X} + F_{3X}$$

$$F_{1Y} + F_{4Y} \sim F_{2Y} + F_{3Y}$$

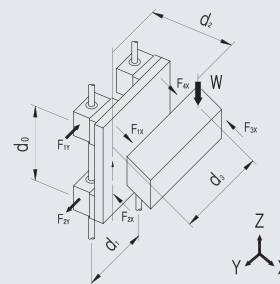

Technical terms : d_0 = distance of Case units' center line

d_2 = distance between carrier's center line and load point

W = Weight(N) F_{NX} = X-axial force(N) F_{NY} = Y-axial force(N)

d_1 = distance LM shaft's center line

d_3 = distance between carrier's center line and load point

F_{NZ} = Z-axial force(N)

Mean Effective Load at Varying Load

The load acting on a linear system changes depending on the application, for example, when the linear system starts or stops reciprocating motion, while it is operating at a fixed speed, and according to whether the linear system carries work or not. For a fluctuating load, it is important to obtain the mean effective load.

For stepped load according to the travelling distance

$$P_m = \sqrt[3]{\frac{1}{L} (P_1^3 \cdot L_1 + P_2^3 \cdot L_2 \dots + P_n^3 \cdot L_n)} \dots\dots\dots (1)$$

- P_m : mean effective load in fluctuation (N)
- P_n : floating load (N)
- L : Total traveling distance (mm)
- L_n : Traveling distance with carrying P_n (mm)

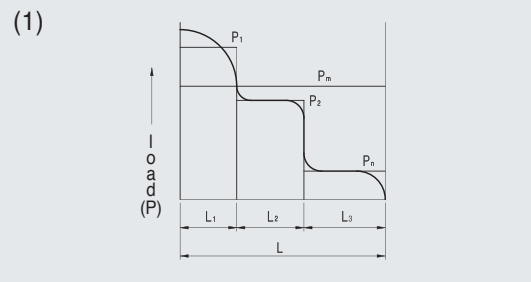

For loads that changes step wisely

For almost linearly varying load

$$P_m \doteq \frac{1}{3} (P_{min} + 2 \cdot P_{max}) \dots\dots\dots (2)$$

- P_m : mean effective load in fluctuation (N)
- P_{min} : Minimum value of fluctuating load (N)
- P_{max} : Maximum value of fluctuating load (N)

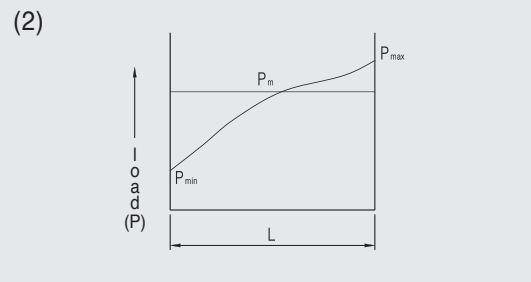

For loads that changes monotonously

When the load draws a sine curve

$$P_m \doteq 0.65 P_{max} \dots\dots\dots (3)$$

$$P_m \doteq 0.75 P_{max} \dots\dots\dots (4)$$

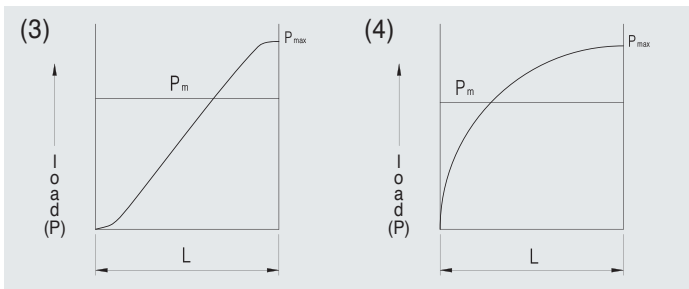

For loads that changes sinusoid ally

49

Would you align, please?

No, I don't need!
I am Self-Aligning!

**Super Ball Self-Aligning Linear Bushing(LMIES, LMBS)
Compact Linear Bushing(CLB)**

High Capacity Self-Aligning Linear Bushing - SUPERBALL

Higher Load Ratings and Travel Life

Specially designed ball plate is made of Hardened steel, and the precisely ground groove is slightly larger than the ball size, which provides greater contact area between the ball and the ball plate. In addition, this design provides 3 times higher load ratings and 27 times longer travel life compared to conventional Linear Bushing.

Self-Alignment

Ball plate has a convex shape to provide a pivot point at the center, which allows Self Alignment up to $\pm 0.5^\circ$. This Self Alignment capability eliminates any possibility of edge pressure caused by inaccurate machining, errors on mounting, or shaft deflection. Moreover, it obtains uniform load distribution and low friction motion.

Smooth and Silent Running

SUPERBALL has extremely smooth running due to the uniquely designed ball retainer and the outer sleeve. They are made of Engineering Polymer, which has light weight, low friction, and high wear-resistance. Due to them, the smooth and silent running can be obtained.

Clearance Adjustment

SUPERBALL's ball plates are designed to float in the outer sleeve. This allows clearance between the balls and shaft to be adjusted for the best application environment by using with the housing.

Interchangeability

Super Ball is designed to be fully interchangeable with conventional linear bushing for European standard or Inch standard product.

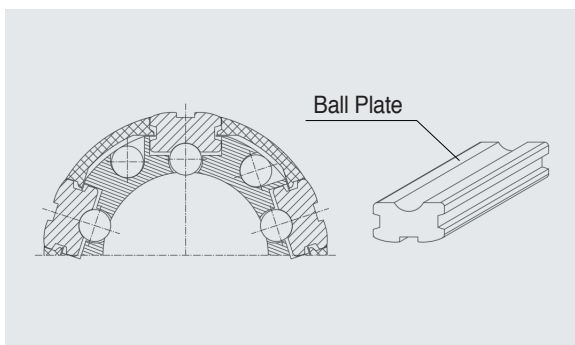

Fig3. Cross-section of SUPERBALL

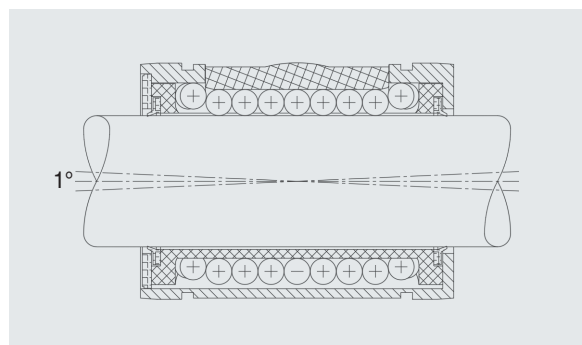

Fig4. SUPERBALL's self-alignment feature

Cost Effectiveness

Lower cost on installation

Self-Alignment feature can compensate the inaccurate machining of the base, so less installation time and cost can be obtained.

Higher load rating and longer travel life

Compared to the same size conventional linear bushings, SUPPERBALL will offer higher load rating and longer travel life against same load.

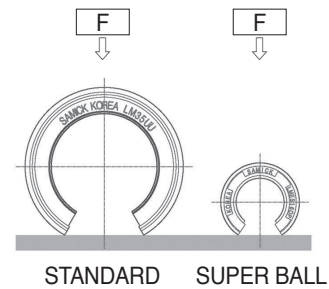

Reduction of material cost

SUPPERBALL's higher load rating enables the use of smaller components, and reducing material cost.

Energy saving

SUPPERBALL is designed with lightweight, lower inertia, and low friction, so it enables the moving parts to have rapid motion with lower driving power.

Load Ratings and Travel Life

SUPPERBALL's load ratings give an influence to travel life with load direction, ball circuit orientation, and hardness of the shaft.

	Orientation of Balls		
No. of Ball Row	4 Row	5 Row	6 Row
Max. Load			
Equation	$F = 1.41 \times C$	$F = 1.46 \times C$	$F = 1.28 \times C$
Min. Load			
Equation	$F = C$	$F = C$	$F = C$

Basic Dynamic load rating(C) and travel life

The travel life of a Linear Bushing is determined largely by the quality of the shaft. The Basic Dynamic load rating is maximum continuous load that can be applied to the Linear Bushing with 90% of reliability achieving after 50km operation under normal conditions. The nominal travel life can be calculated by follow equation.

$$L_{10} = \left[\frac{C}{P} \right]^3 \times 50$$

L_{10} : Nominal life (unit : km)
 C : Basic dynamic load rating (unit : N)
 P : Calculated load (N)

Practically, other factors will affect the life as follows

$$L_{10} = \left[\frac{f_H \times f_T \times f_C}{f_W} \times \frac{C}{P} \right]^3 \times 50$$

f_W : Load factor
 f_H : Hardness factor
 f_T : Temperature factor
 f_C : Contact factor

From the above equations, the stroke and frequency are constant, the Travel Life can be calculated by following equation

$$L_h = \frac{L \times 10^6}{2 \times l_s \times N_l \times 60}$$

L_h : Travel life(hour)
 l_s : Stroke(mm)
 N_l : Number of strokes per minute(cpm)

Examples of Calculation and Choosing a proper SUPERBALL

The Maximum applied load and the travel life are the most important factor for choosing a proper Linear Bushing size. Below are the sample calculation of the expecting travel life and choosing of proper Linear Bushing size.

< Working conditions >

- Applied load	: 250N (P)	- Stroke	: 250mm (l_s)
- Number of strokes per minutes	: 60 (N_l)	- Shaft Hardness	: HRc60 ($f_H = 1.0$)
- Operating speed	: 30m/min		

$$\begin{aligned} \text{Operating Speed } V &= 2 \times l_s \times N_l \\ &= 2 \times 250 \times 60 \\ &= 30,000 \text{mm/min} \quad (f_w = 1.6) \end{aligned}$$

Other factors (f_c, f_T) are considered as 1.0

Calculation of expected travel life

Since, basic dynamic load rating is based on travel life of 50km and assuming all other factors as 1.0, you can choose the Linear Bushing size that you can expected Travel life. Let's try LMES20UU with the above working conditions.

$$L_{10} = \left[\frac{1.0 \times 1.0 \times 1.0}{1.6} \times \frac{2,580}{250} \right]^3 \times 50 \quad L_h = \frac{13,417 \times 10^6}{2 \times 250 \times 60 \times 60}$$

$$\approx 13,417 \text{ km} \quad \approx 7,454 \text{ hours}$$

Choosing proper Linear Bushing

Let's assume our design travel life is 15,000hours,

$$L_{10} = 15,000 \times 2 \times 250 \times 10^{-6} \times 60 \times 60 = 27,000 \text{ km}$$

$$C = \frac{250 \times 1.6}{1.0 \times 1.0 \times 1.0} \times \sqrt[3]{\frac{27,000}{50}} = 3,257 \text{ N}$$

Therefore, the proper SUPERBALL for above condition is LMES25UU which has 3800N as the Basic dynamic load rating(C).

Housing and Shaft

Housing

For SUPERBALL's application, Housing is required. Tolerance of Housing bore will affect the life and the accuracy of application. See the below Table However, if the tolerance of housing is H7, tight fitting can be occurred at both ends of outer- sleeves in case of LMES type

Table4. Housing and tight fitting

Part number(mm)	LMES10	LMES12	LMES16	LMES20	LMES25	LMES30	LMES40	LMES50			
Inner diameter(mm)	19	22	26	32	40	47	62	75			
Tolerance (H7)	+0.021 0			+0.025 0			+0.030 0				
Part number(inch)	LMBS04	LMBS06	LMBS08	LMBS10	LMBS12	LMBS16	LMBS20	LMBS24	LMBS32		
Inner diameter(inch)	0.5	0.625	0.875	1.125	1.25	1.5625	2	2.375	3		
Tolerance (H7)	+0.0007 0		+0.0008 0		+0.0010 0		+0.0012 0				
Part number(mm)	CLB08S	CLB08	CLB10	CLB12	CLB14	CLB16	CLB20	CLB25	CLB30	CLB40	CLB50
Inner diameter(mm)	15		17	19	21	24	28	35	40	52	62
Tolerance (H7)	+0.018 0			+0.021 0			+0.025 0		+0.030 0		

LM Shaft

Because the balls in SAMICK SUPERBALL as rolling elements are running directly on the shaft surface, the hardness, surface finish, and tolerance of shaft will largely affect on the traveling performance of SUPERBALL. The shaft must be manufactured with following conditions;

1) Hardness

The hardness must be H_RC58 to 64. The shaft with hardness less than H_RC58 will lead decreasing of travel life and permissible load.

2) Surface Finishing

The surface finishing must be 1.6S or better for smooth operation.

3) Tolerance

The correct tolerance of the shaft diameter is recommended. See the below table.

Table5. Shaft and tight fitting

Part number(mm)	LMES10	LMES12	LMES16	LMES20	LMES25	LMES30	LMES40	LMES50			
Diameter(mm)	10	12	16	20	25	30	40	50			
Tolerance (h6)	0 -0.009	0 -0.011			0 -0.013		0 -0.016				
Part number(inch)	LMBS04	LMBS06	LMBS08	LMBS10	LMBS12	LMBS16	LMBS20	LMBS24	LMBS32		
Diameter(inch)	0.25	0.375	0.500	0.625	0.750	1.000	1.250	1.500	2.000		
Tolerance (g6)	-0.0002 -0.0006		-0.0002 -0.0007		-0.0003 -0.0008		-0.0004 -0.0010		-0.0004 -0.0012		
Part number(mm)	CLB08S	CLB08	CLB10	CLB12	CLB14	CLB16	CLB20	CLB25	CLB30	CLB40	CLB50
Diameter(mm)		8	10	12	14	16	20	25	30	40	50
Tolerance (h6)		0 -0.009			0 -0.011			0 -0.013		0 -0.016	

PART NUMBER NOTATION

● Self-aligning Linear Bushing

LM ES 16 UU OP - N S

● SAMICK Linear Bushing

● Standard Selection(Europe, US)

ES	Metric series (mm)
BS	Inch series (inch)

● Nominal Shaft Diameter

10~50mm	Metric (mm)
#4~#32	Inch series (inch)

● Seal

Blank	No Seal
UU	Both Side Seal
U	One Side Seal

● Sloting Type

Blank	Standard type
OP	Open type(for support rail)

● Corrosion resistance type

Blank	Stainless steel
N	Electroless nickel plating

● Ball type (material)

Blank	Standard(High Carbon Chromium Bearing Steel Ball)
S	Stainless steel ball

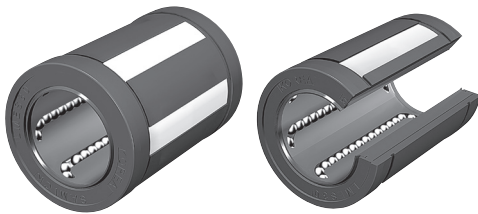

LMES Self-Aligning Linear Bushing

● Drawing

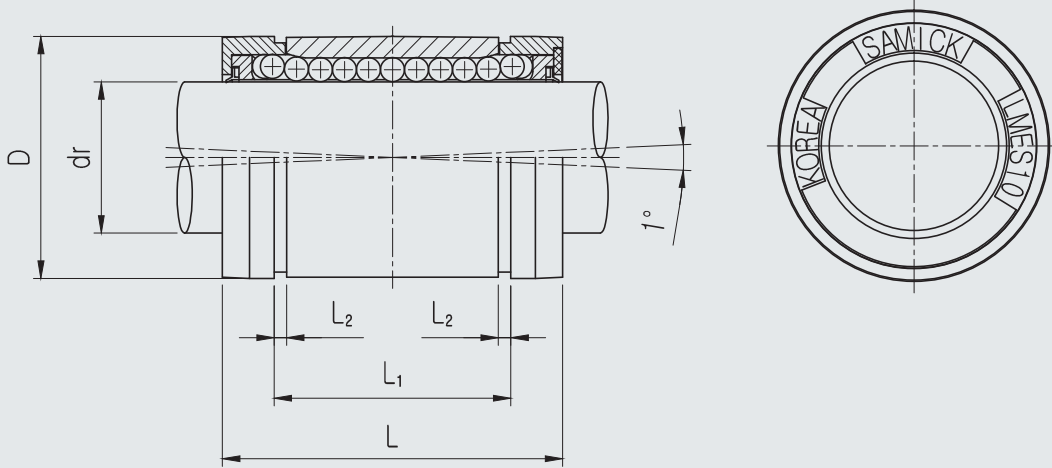

● Part Number Notation

LMES 20 UU - N S

- Self-aligning Linear Bushing(Europeanstandard)
- Nominal Shaft Diameter
- Seal

Blank	No Seal
UU	Both Side Seal
U	One Side Seal

- Corrosion resistance type

Blank	Stainless steel
N	Electroless nickel plating

- Ball type (material)

Blank	Standard(High Carbon Chromium Bearing Steel Ball)
S	Stainless steel ball



LMES Self-Aligning Linear Bushing

PART NUMBER	Working Bore Diameter		D* ¹ mm	L ±0.2	L ₁		L ₂ min	BASIC LOAD RATING(N)		NO. OF BALL CIRCUIT	WEIGHT (gf)
	dr. (mm)	BORE DIAMETER Tolerance						DYNAMIC (C)* ²	STATIC (Co)		
LMES10UU	10	+0.008 0	19	29	21.7	+0.2 0	1.35	750	550	5	17
LMES12UU	12		22	32	22.7		1.35	1,230	1,100	5	23
LMES16UU	16	+0.009 -0.001	26	36	24.7		1.35	1,550	1,250	5	28
LMES20UU	20		32	45	31.2		1.60	2,580	1,670	6	61
LMES25UU	25	+0.011 -0.001	40	58	43.7		1.85	3,960	2,750	6	122
LMES30UU	30		47	68	51.7		1.85	4,410	2,800	6	185
LMES40UU	40	+0.013 -0.002	62	80	60.4		2.20	8,300	5,720	6	360
LMES50UU	50		75	100	77.4		2.70	12,000	7,940	6	580

★1 Based on nominal housing bore

★2 Dynamic load rating is based on the nominal life of 50km.

★3 Main unit : mm

★4 1N ≒0.102kgf

LMES_OP Open Self-Aligning Linear Bushing

● Drawing

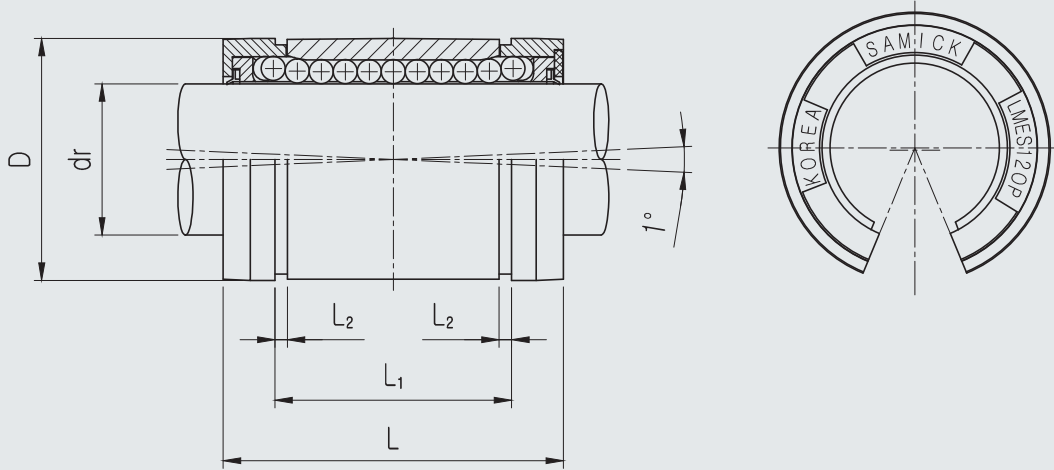

● Part Number Notation

LMES 20 UU OP - N S

- Self-aligning Linear Bushing(European standard)
- Nominal Shaft Diameter
- Seal

Blank	No Seal
UU	Both Side Seal
U	One Side Seal

- Open type Linear Bushing
- Corrosion resistance type

Blank	Stainless steel
N	Electroless nickel plating

- Ball type (material)

Blank	Standard(High Carbon Chromium Bearing Steel Ball)
S	Stainless steel ball

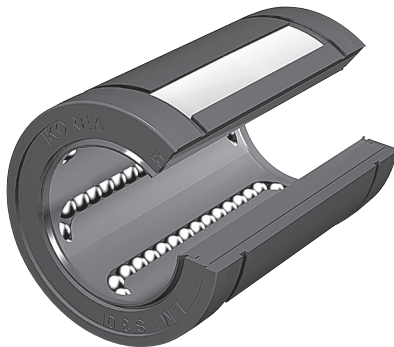

LMES_OP Open Self-Aligning Linear Bushing

PART NUMBER	Working Bore Diameter		D ^{★1} mm	L ±0.2	L ₁	L ₂ min	h	θ	F	G	J	BASIC LOAD RATING(N)		NO. OF BALL CIRCUIT	WEIGHT (gf)	
	dr. (mm)	BORE DIAMETER Tolerance										DYNAMIC (C) ^{★2}	STATIC (Co)			
LMES12UUOP	12	+0.008 0	22	32	22.7	+0.2 0	1.35	6.5	66	Ø3.2	-	0.7	1,590	1,100	4	18
LMES16UUOP	16	+0.009 -0.001	26	36	24.7		1.35	9	68	Ø3.2	-	0.7	2,060	1,250	4	22
LMES20UUOP	20		32	45	31.2		1.65	9	55	Ø3.2	-	0.9	2,770	1,670	5	51
LMES25UUOP	25	+0.011 -0.001	40	58	43.7		1.90	11.5	57	Ø3.2	1.5	1.4	4,310	2,750	5	102
LMES30UUOP	30		47	68	51.7		1.90	14	57	Ø3.2	2.0	2.2	4,810	2,800	5	155
LMES40UUOP	40	+0.013 -0.002	62	80	60.4		2.20	19.5	56	Ø3.2	1.5	2.9	9,100	5,720	5	300
LMES50UUOP	50		75	100	77.4		2.70	22.5	54	Ø5.2	2.5	2.3	12,900	7,940	5	480

※ Fixing hole position

LMES12-OP

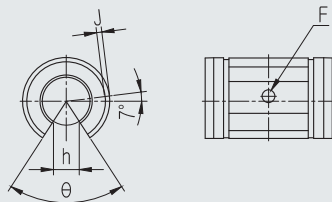

LMES16-OP, LMES20-OP

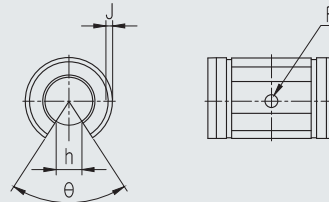

LMES25-OP

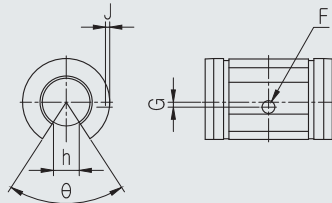

LMES30-OP, LMES40-OP, LMES50-OP

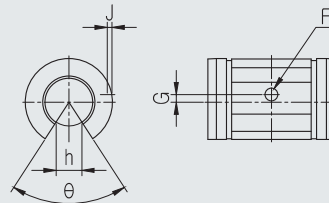

- ★1 Based on nominal housing bore
- ★2 Dynamic load rating is based on the nominal life of 50km.
- ★3 Main unit : mm
- ★4 1N ≒0.102kgf

LMBS Self-Aligning Linear Bushing

● Drawing

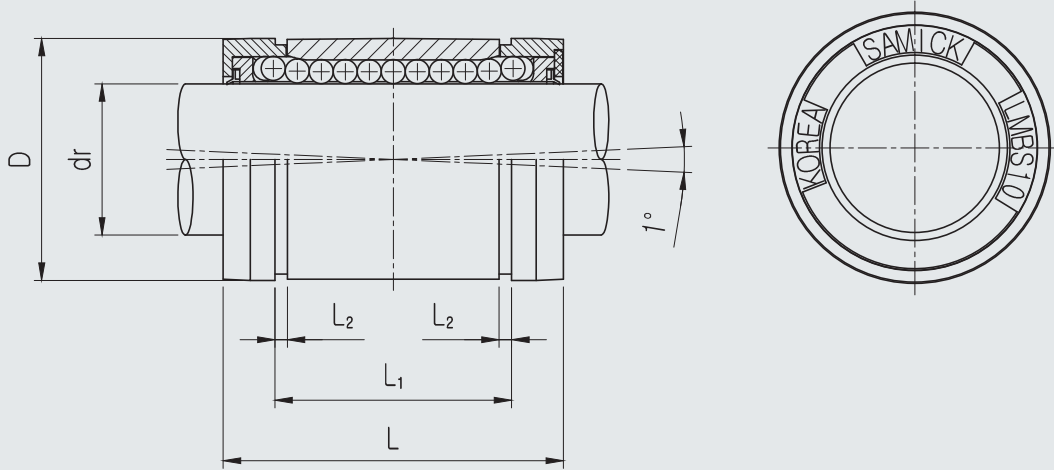

● Part Number Notation

LMBS 20 UU - N S

● Self-aligning Linear Bushing (inch type)

● Nominal Shaft Diameter

● Seal

Blank	No Seal
UU	Both Side Seal
U	One Side Seal

● Corrosion resistance type

Blank	Stainless steel
N	Electroless nickel plating

● Ball type (material)

Blank	Standard (High Carbon Chromium Bearing Steel Ball)
S	Stainless steel ball



LMBS Self-Aligning Linear Bushing

PART NUMBER	Working Bore Diameter		D* ¹ (inch)	L	L ₁	L ₂ min	BASIC LOAD RATING(lbf)		NO. OF BALL CIRCUIT	WEIGHT (gf)
	dr. (inch)	BORE DIAMETER Tolerance					DYNAMIC (C)* ²	STATIC (Co)		
LMBS04UU	0.2500	0 -0.0005	0.5000	0.750/0.735	0.511/0.501	0.039	60	49	4	0.01
LMBS06UU	0.3750		0.6250	0.875/0.860	0.699/0.689	0.039	75	66	4	0.02
LMBS08UU	0.5000		0.8750	1.250/1.230	1.032/1.012	0.050	195	190	4	0.05
LMBS10UU	0.6250		1.1250	1.500/1.480	1.105/1.095	0.056	365	340	5	0.08
LMBS12UU	0.7500		1.2500	1.625/1.605	1.270/1.250	0.056	505	430	6	0.14
LMBS16UU	1.0000		1.5625	2.250/2.230	1.884/1.864	0.070	895	780	6	0.29
LMBS20UU	1.2500	0 -0.0006	2.0000	2.625/2.600	2.004/1.984	0.068	1,320	1,270	6	0.40
LMBS24UU	1.5000		2.3750	3.000/2.970	2.410/2.390	0.086	1,850	1,540	6	0.80
LMBS32UU	2.0000	0 -0.0008	3.0000	4.000/3.960	3.193/3.163	0.105	2,735	2,580	6	1.38

- ★1 Based on nominal housing bore
- ★2 Dynamic load rating is based on the nominal life of 50km.
- ★3 Main unit : inch
- ★4 1 lbf = 0.453kgf

LMBS_OP Open Self-Aligning Linear Bushing

● Drawing

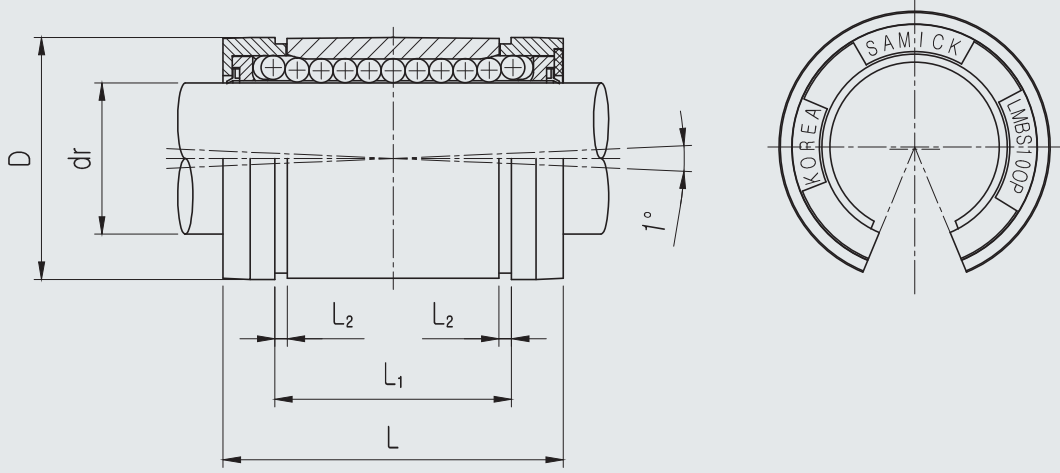

● Part Number Notation

LMBS 20 UU OP - N S

- Self-aligning Linear Bushing (inch type)
- Nominal Shaft Diameter
- Seal

Blank	No Seal
UU	Both Side Seal
U	One Side Seal

- Open type
- Corrosion resistance type

Blank	Stainless steel
N	Electroless nickel plating

- Ball type (material)

Blank	Standard (High Carbon Chromium Bearing Steel Ball)
S	Stainless steel ball

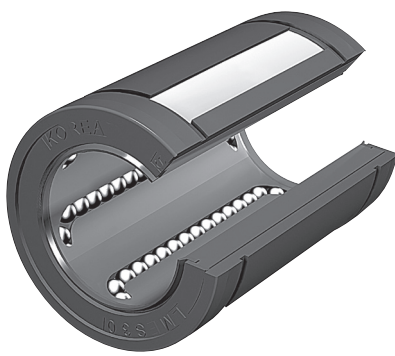

LMBS_OP Open Self-Aligning Linear Bushing

PART NUMBER	Working Bore Diameter		D* ¹ (inch)	L	L ₁	F	G	J	L ₂ min	h	BASIC LOAD RATING(lbf)		NO. OF BALL CIRCUIT	WEIGHT (gf)
	dr. (inch)	BORE DIAMETER Tolerance									DYNAMIC (C) ^{*2}	STATIC (Co)		
LMBS08UUOP	0.5000	0 -0.0005	0.8750	1.250/1.230	1.022/1.012	0.14	0.63	Thru	0.050	0.32	195	190	3	0.03
LMBS10UUOP	0.6250		1.1250	1.500/1.480	1.105/1.095	0.11	0.13	0.039	0.056	0.38	480	340	4	0.06
LMBS12UUOP	0.7500		1.2500	1.625/1.605	1.270/1.250	0.14	0.13	0.051	0.056	0.43	560	430	5	0.11
LMBS16UUOP	1.0000		1.5625	2.250/2.230	1.884/1.864	0.14	0.13	0.047	0.070	0.56	1,010	780	5	0.21
LMBS20UUOP	1.2500	0 -0.0006	2.0000	2.625/2.600	2.004/1.984	0.20	0.19	0.087	0.068	0.63	1,510	1,270	5	0.35
LMBS24UUOP	1.5000		2.3750	3.000/2.970	2.409/2.390	0.20	0.19	0.090	0.086	0.75	2,100	1,540	5	0.67
LMBS32UUOP	2.0000	0 -0.0008	3.0000	4.000/3.960	3.195/3.165	0.27	0.31	0.124	0.105	1.00	3,050	2,580	5	1.10

* Fixing hole position

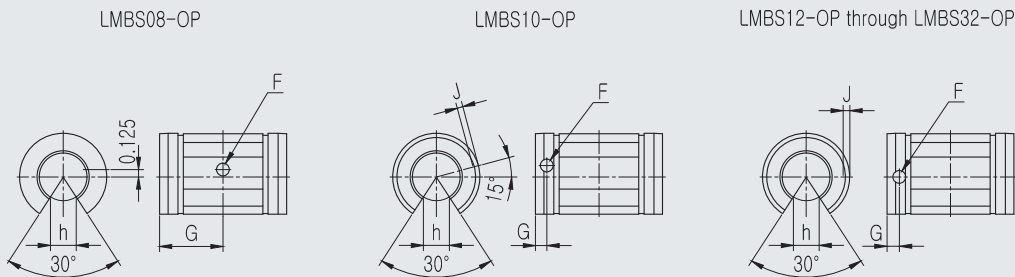

- ★1 Based on nominal housing bore
- ★2 Dynamic load rating is based on the nominal life of 50km.
- ★3 Main unit : inch
- ★4 1 lbf = 0.453kgf

CLB Compact Linear Bushing

● Drawing

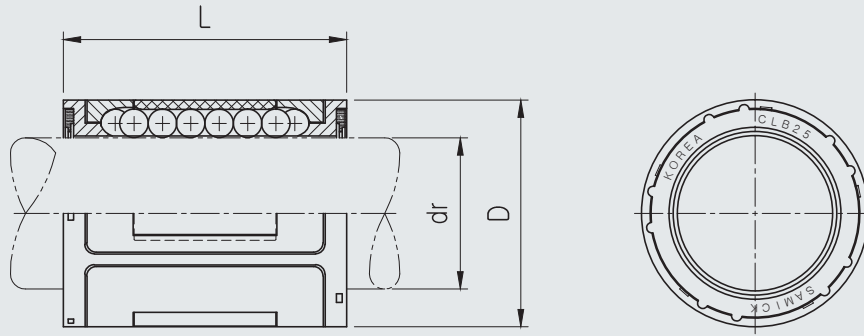

● Part Number Notation

CLB 20 UU - N S

- Compact Linear Bushing
- Nominal Shaft Diameter
- Seal

Blank	No Seal
UU	Both Side Seal
U	One Side Seal

- Corrosion resistance type

Blank	Stainless steel
N	Electroless nickel plating

- Ball type (material)

Blank	Standard(High Carbon Chromium Bearing Steel Ball)
S	Stainless steel ball

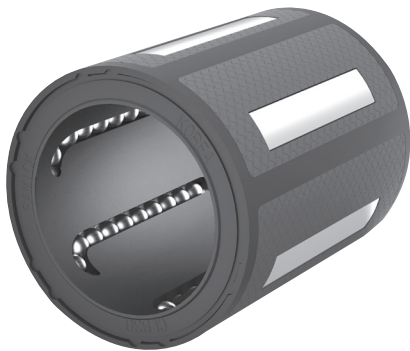

CLB Compact Linear Bushing

Part Number		No. OF BALL CIRCUIT	OUTER DIAMETER	LENGTH		WORKING BORE DIAMETER		BASIC LOAD RATING(N) ^{*2}		WEIGHT (gf)
Without Seal	With Seal		D ^{*1} (mm)	L(mm)	Tolerance (mm)	dr(mm)	Tolerance (mm)	DYNAMIC (C)	STATIC (Co)	
CLB08S	CLB08SUU	4	15	17	±0.3	8	+0.008 0	285	142	4.1
CLB08	CLB08UU	4	15	24		8		414	260	6.3
CLB10	CLB10UU	4	17	26		10		498	320	7.7
CLB12	CLB12UU	4	19	28		12		791	385	13.2
CLB14	CLB14UU	5	21	28		14	904	440	15.0	
CLB16	CLB16UU	5	24	30		16	+0.009 -0.001	1,162	625	21.4
CLB20	CLB20UU	6	28	30		20	1,463	790	21.6	
CLB25	CLB25UU	6	35	40		25	+0.011 -0.001	2,154	1,370	57.2
CLB30	CLB30UU	6	40	50		30		3,780	2,100	80.4
CLB40	CLB40UU	7	52	60		40	+0.013 -0.002	6,520	4,100	143.3
CLB50	CLB50UU	8	62	70	50	8,030		5,600	197.9	

- ★1 Based on nominal housing bore
- ★2 Dynamic load rating is based on the nominal life of 50km.
- ★3 Main unit : mm
- ★4 1N= 0.102kgf
- ★5 The dimensions are in accordance with ISO 10285 series 1.
- ★6 Recommended housing bore tolerance : H7
Recommended Shaft diameter tolerance : h6

LMES-SUS Self-Aligning Linear Bushing-SUS SERIES

● Drawing

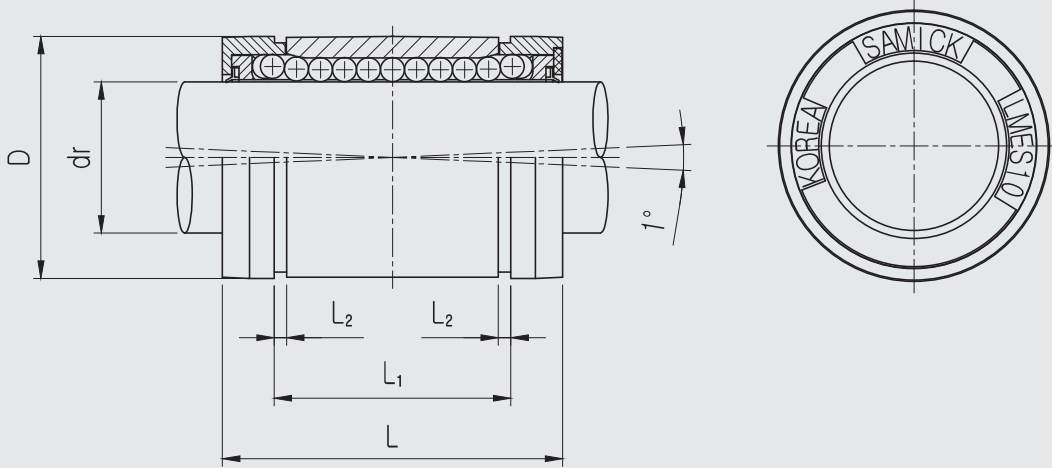

● Part Number Notation

LMES 20 UU - SUS

- Self-aligning Linear Bushing(Europeanstandard)
- Nominal Shaft Diameter
- Seal

Blank	No Seal
UU	Both Side Seal
U	One Side Seal

- Ball Plate & Ball

SUS	Ball Plate : Stainless steel
	Ball : Stainless steel



LMES-SUS Self-Aligning Linear Bushing-SUS SERIES

PART NUMBER	Working Bore Diameter		D* ¹ mm	L ±0.2	L ₁		L ₂ min	BASIC LOAD RATING(N)		NO. OF BALL CIRCUIT	WEIGHT (gf)
	dr. (mm)	BORE DIAMETER Tolerance						DYNAMIC (C)* ²	STATIC (Co)		
LMES10UU	10	+0.008 0	19	29	21.7	+0.2 0	1.35	750	550	5	17
LMES12UU	12		22	32	22.7		1.35	1,230	1,100	5	23
LMES16UU	16	+0.009 -0.001	26	36	24.7		1.35	1,550	1,250	5	28
LMES20UU	20		32	45	31.2		1.60	2,580	1,670	6	61
LMES25UU	25	+0.011 -0.001	40	58	43.7		1.85	3,960	2,750	6	122
LMES30UU	30		47	68	51.7		1.85	4,410	2,800	6	185
LMES40UU	40	+0.013 -0.002	62	80	60.4		2.20	8,300	5,720	6	360
LMES50UU	50		75	100	77.4		2.70	12,000	7,940	6	580

- ★1 Based on nominal housing bore
- ★2 Dynamic load rating is based on the nominal life of 50km.
- ★3 Main unit : mm
- ★4 1N ≒0.102kgf

LMES_OP-SUS Open Self-Aligning Linear Bushing-SUS SERIES

● Drawing

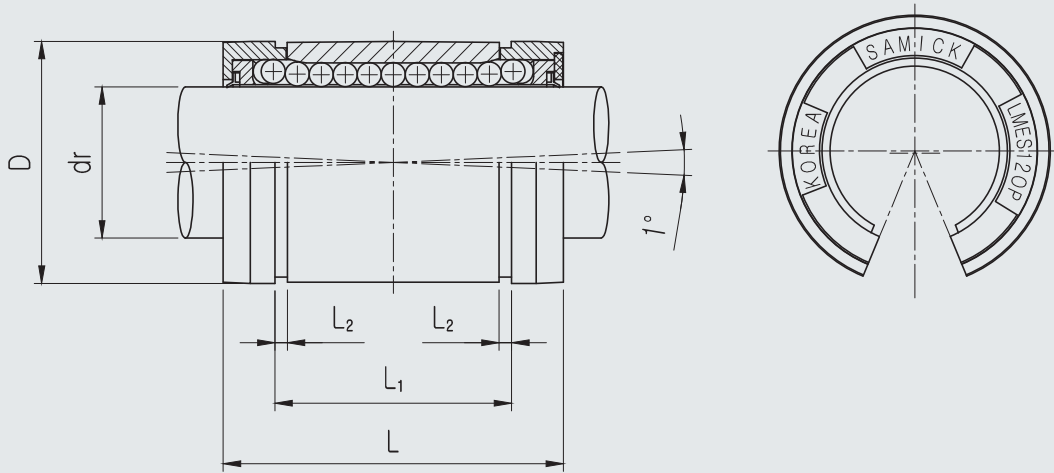

● Part Number Notation

LMES 20 UU OP - SUS

- Self-aligning Linear Bushing(Europeanstandard)
- Nominal Shaft Diameter
- Seal

Blank	No Seal
UU	Both Side Seal
U	One Side Seal

- Open type Linear Bushing
- Ball Plate & Ball

SUS	Ball Plate : Stainless steel
	Ball : Stainless steel

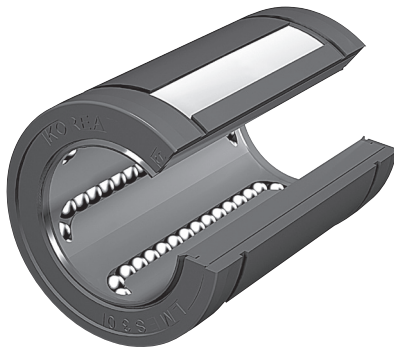

LMES_OP-SUS Open Self-Aligning Linear Bushing-SUS SERIES

PART NUMBER	Working Bore Diameter		D*1 mm	L ±0.2	L1	L2 min	h	θ	F	G	J	BASIC LOAD RATING(N)		NO. OF BALL CIRCUIT	WEIGHT (gf)	
	dr. (mm)	BORE DIAMETER Tolerance										DYNAMIC (C)*2	STATIC (Co)			
LMES12UUOP	12	+0.008 0	22	32	22.7	+0.2 0	1.35	6.5	66	Ø3.2	-	0.7	1,590	1,100	4	18
LMES16UUOP	16	+0.009 -0.001	26	36	24.7		1.35	9	68	Ø3.2	-	0.7	2,060	1,250	4	22
LMES20UUOP	20		32	45	31.2		1.65	9	55	Ø3.2	-	0.9	2,770	1,670	5	51
LMES25UUOP	25	+0.011 -0.001	40	58	43.7		1.90	11.5	57	Ø3.2	1.5	1.4	4,310	2,750	5	102
LMES30UUOP	30		47	68	51.7		1.90	14	57	Ø3.2	2.0	2.2	4,810	2,800	5	155
LMES40UUOP	40	+0.013 -0.002	62	80	60.4		2.20	19.5	56	Ø3.2	1.5	2.9	9,100	5,720	5	300
LMES50UUOP	50		75	100	77.4		2.70	22.5	54	Ø5.2	2.5	2.3	12,900	7,940	5	480

※ Fixing hole position

LMES12-OP

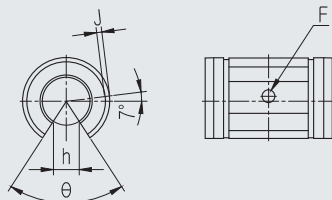

LMES16-OP, LMES20-OP

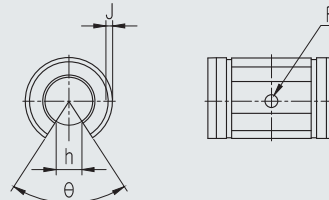

LMES25-OP

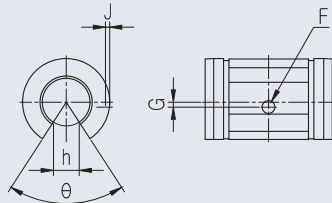

LMES30-OP, LMES40-OP, LMES50-OP

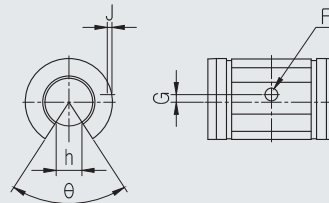

- ★1 Based on nominal housing bore
- ★2 Dynamic load rating is based on the nominal life of 50km.
- ★3 Main unit : mm
- ★4 1N ≒0.102kgf

LMBS-SUS Self-Aligning Linear Bushing-SUS SERIES

● Drawing

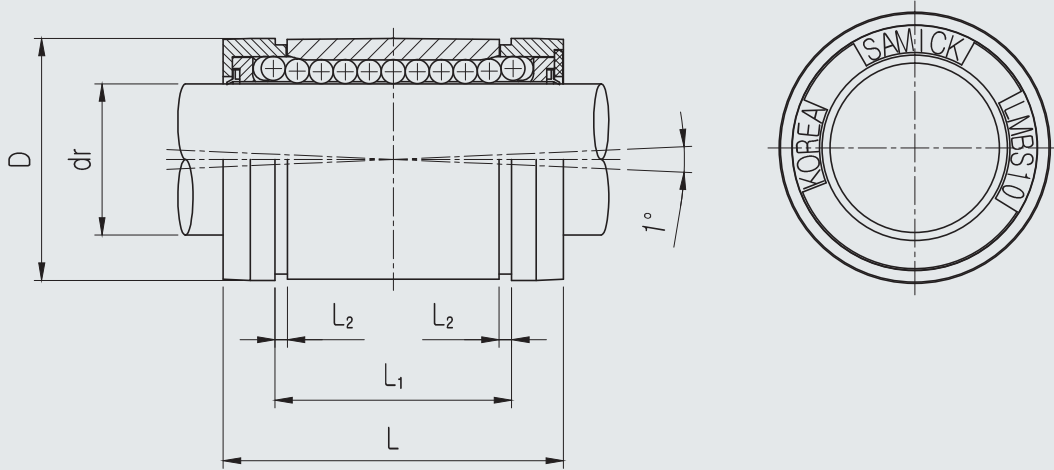

● Part Number Notation

LMBS 20 UU - SUS

● Self-aligning Linear Bushing (inch type)

● Nominal Shaft Diameter

● Seal

● Ball Plate & Ball

Blank	No Seal
UU	Both Side Seal
U	One Side Seal

SUS	Ball Plate : Stainless steel
	Ball : Stainless steel



LMBS-SUS Self-Aligning Linear Bushing-SUS SERIES

PART NUMBER	Working Bore Diameter		D* ¹ (inch)	L	L ₁	L ₂ min	BASIC LOAD RATING(lbf)		NO. OF BALL CIRCUIT	WEIGHT (gf)
	dr. (inch)	BORE DIAMETER Tolerance					DYNAMIC (C)* ²	STATIC (Co)		
LMBS04UU	0.2500	0 -0.0005	0.5000	0.750/0.735	0.511/0.501	0.039	60	49	4	0.01
LMBS06UU	0.3750		0.6250	0.875/0.860	0.699/0.689	0.039	75	66	4	0.02
LMBS08UU	0.5000		0.8750	1.250/1.230	1.032/1.012	0.050	195	190	4	0.05
LMBS10UU	0.6250		1.1250	1.500/1.480	1.105/1.095	0.056	365	340	5	0.08
LMBS12UU	0.7500		1.2500	1.625/1.605	1.270/1.250	0.056	505	430	6	0.14
LMBS16UU	1.0000		1.5625	2.250/2.230	1.884/1.864	0.070	895	780	6	0.29
LMBS20UU	1.2500	0 -0.0006	2.0000	2.625/2.600	2.004/1.984	0.068	1,320	1,270	6	0.40
LMBS24UU	1.5000		2.3750	3.000/2.970	2.410/2.390	0.086	1,850	1,540	6	0.80
LMBS32UU	2.0000	0 -0.0008	3.0000	4.000/3.960	3.193/3.163	0.105	2,735	2,580	6	1.38

- ★1 Based on nominal housing bore
- ★2 Dynamic load rating is based on the nominal life of 50km.
- ★3 Main unit : inch
- ★4 1 lbf = 0.453kgf

LMBS_OP-SUS Open Self-Aligning Linear Bushing-SUS SERIES

● Drawing

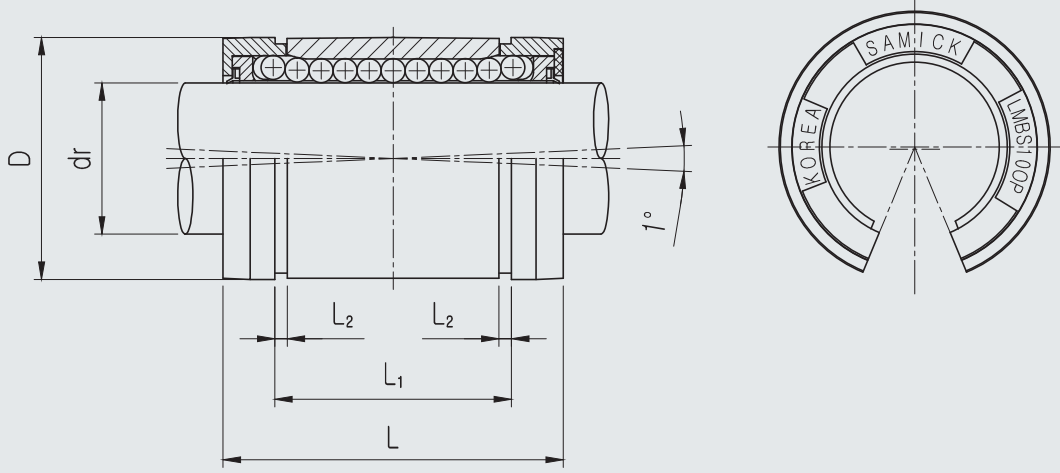

● Part Number Notation

LMBS 20 UU OP - SUS

- Self-aligning Linear Bushing(inch type))
- Nominal Shaft Diameter
- Seal
- Open type
- Ball Plate & Ball

Blank	No Seal
UU	Both Side Seal
U	One Side Seal

SUS	Ball Plate : Stainless steel
	Ball : Stainless steel

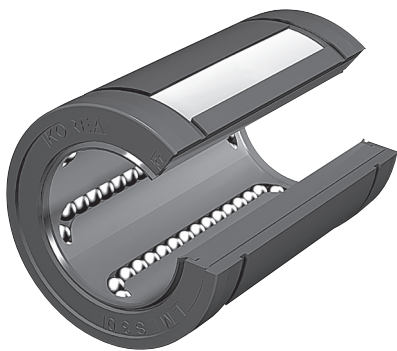

LMBS_OP-SUS Open Self-Aligning Linear Bushing-SUS SERIES

PART NUMBER	Working Bore Diameter		D* ¹ (inch)	L	L ₁	F	G	J	L ₂ min	h	BASIC LOAD RATING(lbf)		NO. OF BALL CIRCUIT	WEIGHT (gf)
	dr. (inch)	BORE DIAMETER Tolerance									DYNAMIC (C)* ²	STATIC (Co)		
LMBS08UUOP	0.5000	0 -0.0005	0.8750	1.250/1.230	1.022/1.012	0.14	0.63	Thru	0.050	0.32	195	190	3	0.03
LMBS10UUOP	0.6250		1.1250	1.500/1.480	1.105/1.095	0.11	0.13	0.039	0.056	0.38	480	340	4	0.06
LMBS12UUOP	0.7500		1.2500	1.625/1.605	1.270/1.250	0.14	0.13	0.051	0.056	0.43	560	430	5	0.11
LMBS16UUOP	1.0000		1.5625	2.250/2.230	1.884/1.864	0.14	0.13	0.047	0.070	0.56	1,010	780	5	0.21
LMBS20UUOP	1.2500	0 -0.0006	2.0000	2.625/2.600	2.004/1.984	0.20	0.19	0.087	0.068	0.63	1,510	1,270	5	0.35
LMBS24UUOP	1.5000		2.3750	3.000/2.970	2.409/2.390	0.20	0.19	0.090	0.086	0.75	2,100	1,540	5	0.67
LMBS32UUOP	2.0000	0 -0.0008	3.0000	4.000/3.960	3.195/3.165	0.27	0.31	0.124	0.105	1.00	3,050	2,580	5	1.10

* Fixing hole position

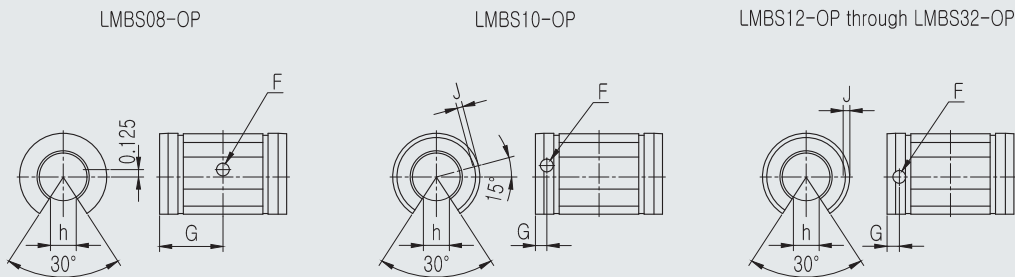

- ★1 Based on nominal housing bore
- ★2 Dynamic load rating is based on the nominal life of 50km.
- ★3 Main unit : inch
- ★4 1 lbf = 0.453kgf

CLB Compact Linear Bushing-SUS SERIES for anti-corrosion

● Drawing

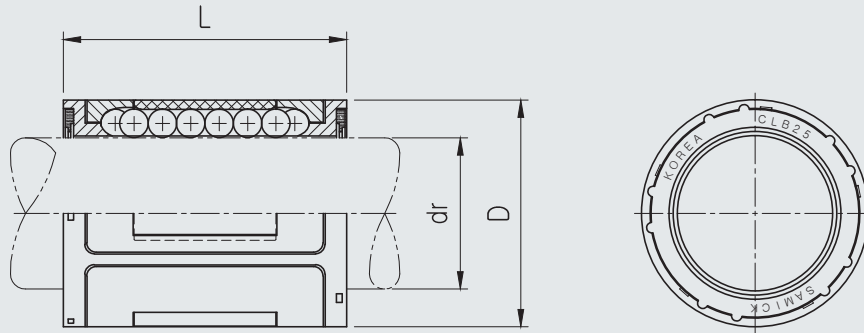

● Part Number Notation

CLB 20 UU - SUS

- Compact Linear Bushing
- Nominal Shaft Diameter
- Seal

Blank	No Seal
UU	Both Side Seal
U	One Side Seal

- Outer-Sleeve : POM
- Ball type : Stainless Steel
- Retainer : POM
- Ball plate : Stainless Steel

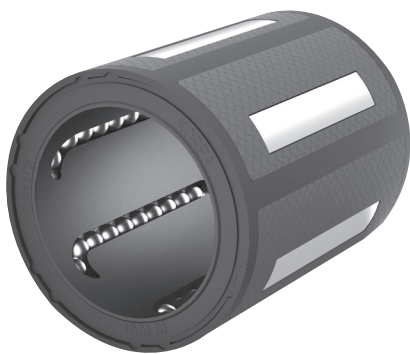

CLB Compact Linear Bushing-SUS SERIES for anti-corrosion

Part Number		No. OF BALL CIRCUIT	DIMENSION			WORKING BORE DIAMETER		BASIC LOAD RATING(N)		WEIGHT (gf)
Without Seal	With Seal		D* ¹ (mm)	L(mm) ±0.2	Tolerance (mm)	dr(mm)	Tolerance (mm)	DYNAMIC* ² (C)	STATIC (Co)	
CLB08S-SUS	CLB08SUU -SUS	4	15	17	±0.3	8	+0.008 0	285	142	4.1
CLB08-SUS	CLB08UU -SUS	4	15	24		8		350	260	6.3
CLB10-SUS	CLB10UU -SUS	4	17	26		10		416	320	7.7
CLB12-SUS	CLB12UU-SUS	4	19	28		12		480	385	13.2
CLB14-SUS	CLB14UU-SUS	5	21	28		14	640	440	15.0	
CLB16-SUS	CLB16UU-SUS	5	24	30		16	+0.009 -0.001	925	625	21.4
CLB20-SUS	CLB20UU-SUS	6	28	30		20	1,165	790	21.6	
CLB25-SUS	CLB25UU-SUS	6	35	40		25	+0.011 -0.001	2,100	1,370	57.2
CLB30-SUS	CLB30UU-SUS	6	40	50		30	2,870	2,100	80.4	
CLB40-SUS	CLB40UU-SUS	7	52	60		40	+0.013 -0.002	5,200	4,100	143.3
CLB50-SUS	CLB50UU-SUS	8	62	70	50	6,620	5,600	197.9		

- ★1 Based on nominal housing bore
- ★2 Dynamic load rating is based on the nominal life of 50km.
- ★3 Main unit : mm
- ★4 1N= 0.102kgf
- ★5 The dimensions are in accordance with ISO 10285 series 1.
- ★6 Recommended housing bore tolerance : H7
Recommended Shaft diameter tolerance : h6



ASIAN STANDARD LINEAR BUSHING(LM)

LM CLOSED LINEAR BUSHING

● Drawing

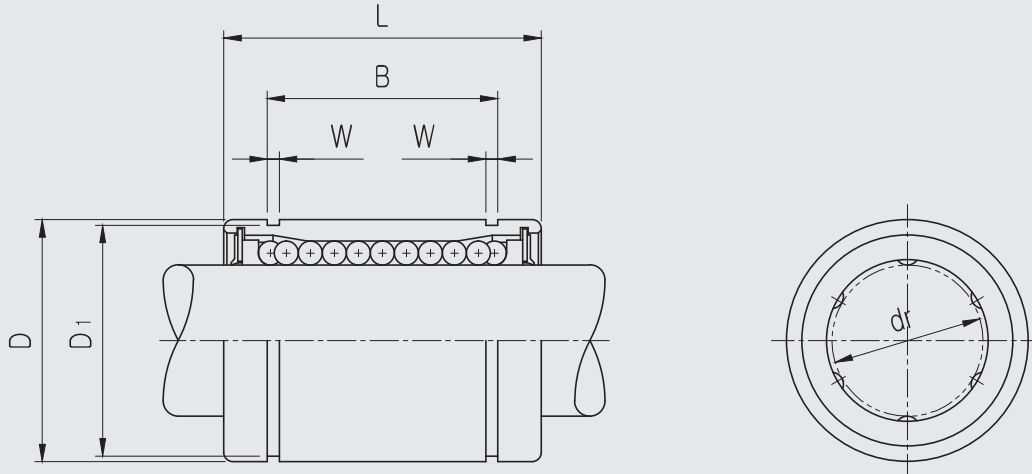

● Part Number Notation

LM 20 UU - A N S



- SAMICK Linear Bushing
- Nominal Shaft Diameter
- Seal

Blank	No Seal
UU	Both Side Seal
U	One Side Seal

- Retainer (material)

Blank	Resin Retainer(Standard)
A	Steel Retainer(High temperature) ★1

- Outer-sleeves (by corrosion resistance)

Blank	Standard(SUJ2)
N	Electroless nickel plating
R	Raydent treatment

- Ball type (material)

Blank	Standard(High Carbon Chromium Bearing Steel Ball)
S	Stainless steel ball

★1 Steel retainer available from LM06 to LM30 only
(LM08S applicable with resin retainer only)

LM CLOSED LINEAR BUSHING

PART NUMBER		WORKING BORE DIAMETER		D		L		B		W	D ₁	BASIC LOAD RATING(N) ^{*4}		NO. OF BALL ROW	WEIGHT (gf) ^{*2}
Resin	Steel ^{*5}	dr. (mm)	Tolerance (mm)	mm	Tolerance (mm)	mm	Tolerance (mm)	mm	Tolerance (mm)			DYNAMIC (C) ^{*1}	STATIC (Co)		
LM05UU		5	0 -0.008	10	0 -0.008	15	0 -0.12	10.2		1.1	9.6	167	206	4	4
LM06UU	LM06-A	6		12		19		13.5		1.1	11.5	200	260	4	8
LM08SUU		8		15	0 -0.011	17		11.5		1.1	14.3	170	220	4	11
LM08UU	LM08-A	8		15		24		17.5		1.1	14.3	260	400	4	16
LM10UU	LM10-A	10	0 -0.009	19		29	0 -0.2	22.0	0 -0.2	1.3	18	370	540	4	30
LM12UU	LM12-A	12		21	0 -0.013	30		23.0		1.3	20	410	590	4	31.5
LM13UU	LM13-A	13		23		32		23.0		1.3	22	500	770	4	43
LM16UU	LM16-A	16		28		37		26.5		1.6	27	770	1,170	5	69
LM20UU	LM20-A	20		32		42		30.5		1.6	30.5	860	1,370	5	87
LM25UU	LM25-A	25	0 -0.010	40	0 -0.016	59		41.0		1.85	38	980	1,560	6	220
LM30UU	LM30-A	30		45		64		44.5		1.85	43	1,560	2,740	6	250
LM35UU		35		52		70	0 -0.3	49.5	0 -0.3	2.1	49	1,660	3,130	6	390
LM40UU		40	0 -0.012	60	0 -0.019	80		60.5		2.1	57	2,150	4,010	6	585
LM50UU		50		80		100		74.0		2.6	76.5	3,820	7,930	6	1,580
LM60UU		60	0 -0.015	90	0 -0.022	110		85.0		3.15	86.5	4,700	9,990	6	2,000
LM80UU		80		120		140	0 -0.4	105.5	0 -0.4	4.15	116	10,130	12,000	6	4,100
	LM100-A ^{*6}	100	0 -0.020	150	0 -0.025	175		125.5		4.15	145	14,100	3,480	6	8,500

★1 Dynamic load rating is based on the nominal life of 50km

★2 Based on the weight of resin retainer

★3 Main unit : mm

★4 1N ≒ 0.102kgf

★5 Steel retainer available from LM06 to LM30 only(Except LM08S, LM08S resing retainer only)

★6 LM100-A is only available with steel retainer

LM_L LONG LINEAR BUSHING

● Drawing

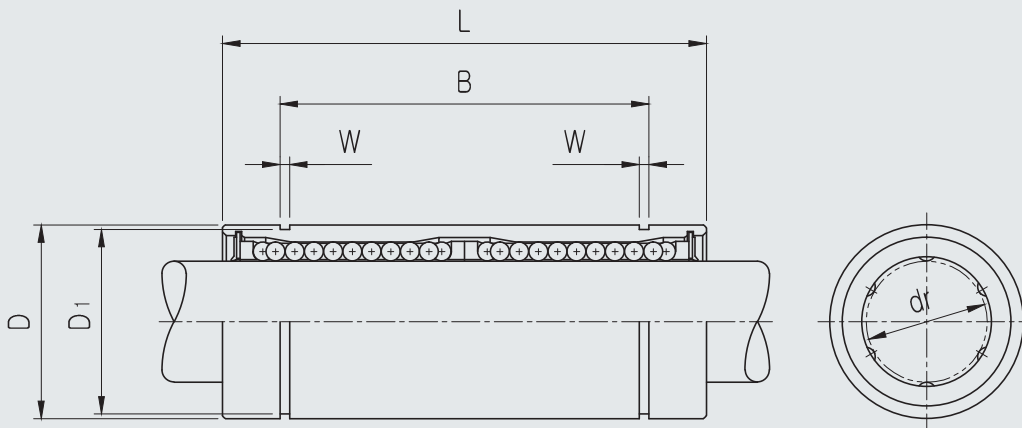

● Part Number Notation

LM 20 L UU - A N S

- SAMICK Linear Bushing
- Nominal Shaft Diameter
- Linear Bushing Long Type (for high load)
- Seal

Blank	No Seal
UU	Both Side Seal
U	One Side Seal

- Retainer (material)

Blank	Resin Retainer(Standard)
A	Steel Retainer(High temperature) ^{★1}

- Outer-sleeves (by corrosion resistance)

Blank	Standard(SUJ2)
N	Electroless nickel plating
R	Raydent treatment

- Ball type (material)

Blank	Standard(High Carbon Chromium Bearing Steel Ball)
S	Stainless steel ball



★1 Steel retainer available from LM06L to LM30L only

LM_L LONG LINEAR BUSHING

PART NUMBER		WORKING BORE DIAMETER		D		L		B		W	D ₁	BASIC LOAD RATING(N) ^{*4}		NO. OF BALL ROW	WEIGHT (gf) ^{*2}		
Resin	Steel ^{*5}	dr. (mm)	Tolerance (mm)	mm	Tolerance (mm)	mm	Tolerance (mm)	mm	Tolerance (mm)			DYNAMIC (C) ^{*1}	STATIC (Co)				
LM06LUU	LM06L-A	6	0 -0.010	12	0 -0.013	35	0 -0.3	27	0 -0.3	1.1	11.5	320	520	4	16		
LM08LUU	LM08L-A	8		15		45		35		1.1	14.3	430	780	4	31		
LM10LUU	LM10L-A	10		19	55	44		1.3		18	580	1,100	4	62			
LM12LUU	LM12L-A	12		21	0 -0.016	57		0 -0.3		46	0 -0.3	1.3	20	650	1,200	4	80
LM13LUU	LM13L-A	13		23		61				46		1.3	22	810	1,570	4	90
LM16LUU	LM16L-A	16		28		70				53		1.6	27	1,230	2,350	5	145
LM20LUU	LM20L-A	20	0 -0.012	32	0 -0.019	80	0 -0.4	61	0 -0.4	1.6	30.5	1,400	2,750	5	180		
LM25LUU	LM25L-A	25		40		112		82		1.85	38	1,560	3,140	6	440		
LM30LUU	LM30L-A	30		45		123		89		1.85	43	2,490	5,490	6	580		
LM35LUU		35	0 -0.015	52	0 -0.022	135	0 -0.4	99	0 -0.4	2.1	49	2,650	6,470	6	795		
LM40LUU		40		60		154		121		2.1	57	3,430	8,040	6	1,170		
LM50LUU		50		80		192		148		2.6	76.5	6,080	15,900	6	3,100		
LM60LUU		60	0 -0.020	90	0 -0.025	211		170		3.15	86.5	7,650	20,000	6	3,500		

- ★1 Dynamic load rating is based on the nominal life of 50km
- ★2 Based on the weight of resin retainer
- ★3 Main unit : mm
- ★4 1N ≒ 0.102kgf
- ★5 Steel retainer available from LM06L to LM30L only

LM_AJ ADJUSTABLE LINEAR BUSHING

● Drawing

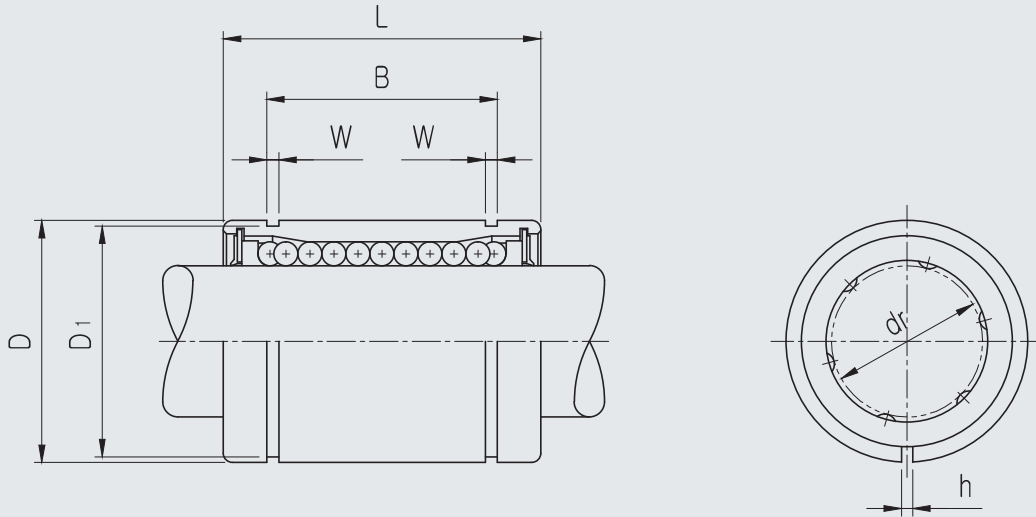

● Part Number Notation

LM 20 UU AJ - A N S



- SAMICK Linear Bushing
- Nominal Shaft Diameter
- Seal

Blank	No Seal
UU	Both Side Seal
U	One Side Seal

- Linear Bushing Adjustable type
- Retainer (material)

Blank	Resin Retainer(Standard)
A	Steel Retainer(High temperature) ★1

- Outer-sleeves (by corrosion resistance)

Blank	Standard(SUJ2)
N	Electroless nickel plating
R	Raydent treatment

- Ball type (material)

Blank	Standard(High Carbon Chromium Bearing Steel Ball)
S	Stainless steel ball

※ ★1 Steel retainer available from LM06AJ to LM30AJ only
LM08S AJ available only with resin retainer

LM_AJ ADJUSTABLE LINEAR BUSHING

PART NUMBER		WORKING BORE DIAMETER		D		L		B		W	h	D ₁	BASIC LOAD RATING(N)		NO. OF BALL ROW	WEIGHT (gf) ^{*2}
Resin	Steel ^{*6}	dr. (mm)	Tolerance (mm)	mm	Tolerance (mm)	mm	Tolerance (mm)	mm	Tolerance (mm)				DYNAMIC (C) ^{*1}	STATIC (Co)		
LM06UUAJ	LM06AJ-A	6		12		19		13.5		1.1	1	11.5	200	260	4	8
LM08SUUAJ		8		15	0 -0.011	17		11.5		1.1	1	14.3	170	220	4	11
LM08UUAJ	LM08AJ-A	8		15		24		17.5		1.1	1	14.3	260	400	4	16
LM10UUAJ	LM10AJ-A	10	0 -0.009	19		29	0 -0.2	22.0	0 -0.2	1.3	1	18	370	540	4	30
LM12UUAJ	LM12AJ-A	12		21	0 -0.013	30		23.0		1.3	1.5	20	410	590	4	31.5
LM13UUAJ	LM13AJ-A	13		23		32		23.0		1.3	1.5	22	500	770	4	43
LM16UUAJ	LM16AJ-A	16		28		37		26.5		1.6	1.5	27	770	1,170	5	69
LM20UUAJ	LM20AJ-A	20		32		42		30.5		1.6	1.5	30.5	860	1,370	5	87
LM25UUAJ	LM25AJ-A	25	0 -0.010	40	0 -0.016	59		41.0		1.85	2	38	980	1,560	6	220
LM30UUAJ	LM30AJ-A	30		45		64		44.5		1.85	2.5	43	1,560	2,740	6	250
LM35UUAJ		35		52		70	0 -0.3	49.5	0 -0.3	2.1	2.5	49	1,660	3,130	6	390
LM40UUAJ		40	0 -0.012	60	0 -0.019	80		60.5		2.1	3	57	2,150	4,010	6	585
LM50UUAJ		50		80		100		74.0		2.6	3	76.5	3,820	7,930	6	1,580
LM60UUAJ		60	0 -0.015	90	0 -0.022	110		85.0		3.15	3	86.5	4,700	9,990	6	2,000

- ★1 Dynamic load rating is based on the nominal life of 50km
- ★2 Based on the weight of resin retainer
- ★3 Main unit : mm
- ★4 Outer diameter is the obtained value before the slotting process.
- ★5 1N ≒ 0.102kgf
- ★6 Steel retainer available from LM06AJ to LM30AJ only
LM08S AJ available only with resin retainer

LM_OP OPEN LINEAR BUSHING

● Drawing

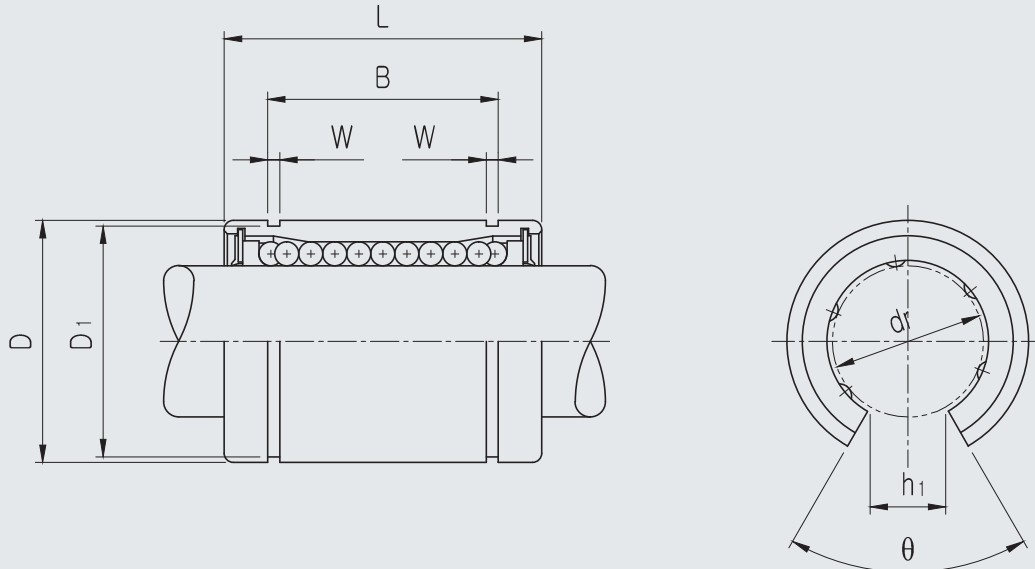

● Part Number Notation

LM 20 UU OP - N S

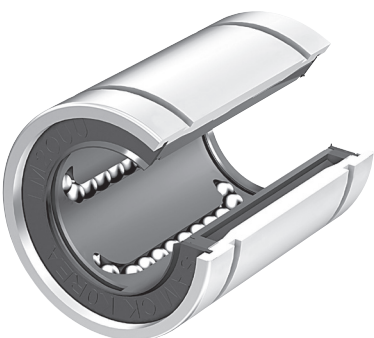

- SAMICK Linear Bushing
- Nominal Shaft Diameter
- Seal

UU	Both Side Seal ^{★1}
----	------------------------------

- Linear Bushing Open type
- Outer-sleeves (by corrosion resistance)

Blank	Standard(SUJ2)
N	Electroless nickel plating
R	Raydent treatment

- Ball type (material)

Blank	Standard(High Carbon Chromium Bearing Steel Ball)
S	Stainless steel ball

* ★1 UU type only available.
 No seal type and one seal type are not available.
 ★ Resin retainer only Available

LM_OP OPEN LINEAR BUSHING

PART NUMBER	WORKING BORE DIAMETER		D*4		L		B		W	h ₁	θ	BASIC LOAD RATING(N)		NO. OF BALL ROW	WEIGHT (gf) ^{*2}
	Resin	dr. (mm)	Tolerance (mm)	mm	Tolerance (mm)	mm	Tolerance (mm)	mm				Tolerance (mm)	DYNAMIC (C) ^{*1}		
LM12UUOP	12		21		30		23.0		1.3	8	80	410	590	3	31.5
LM13UUOP	13	0 -0.009	23	0 -0.013	32	0 -0.2	23.0	0 -0.2	1.3	9	80	500	770	3	43
LM16UUOP	16		28		37		26.5		1.6	11	80	770	1,170	4	69
LM20UUOP	20		32		42		30.5		1.6	11	60	860	1,370	4	87
LM25UUOP	25	0 -0.010	40	0 -0.016	59		41.0		1.85	12	50	980	1,560	5	220
LM30UUOP	30		45		64		44.5		1.85	15	50	1,560	2,740	5	250
LM35UUOP	35		52		70	0 -0.3	49.5	0 -0.3	2.1	17	50	1,660	3,130	5	390
LM40UUOP	40	0 -0.012	60	0 -0.019	80		60.5		2.1	20	50	2,150	4,010	5	585
LM50UUOP	50		80		100		74.0		2.6	25	50	3,820	7,930	5	1,580
LM60UUOP	60	0 -0.015	90	0 -0.022	110		85.0		3.15	30	50	4,700	9,990	5	2,000

- ★1 Dynamic load rating is based on the nominal life of 50km
- ★2 Based on the weight of resin retainer
- ★3 Main unit : mm
- ★4 Outer diameter is the obtained value before the slotting process.
- ★5 1N ≒ 0.102kgf

LMF FLANGED LINEAR BUSHING

● Drawing

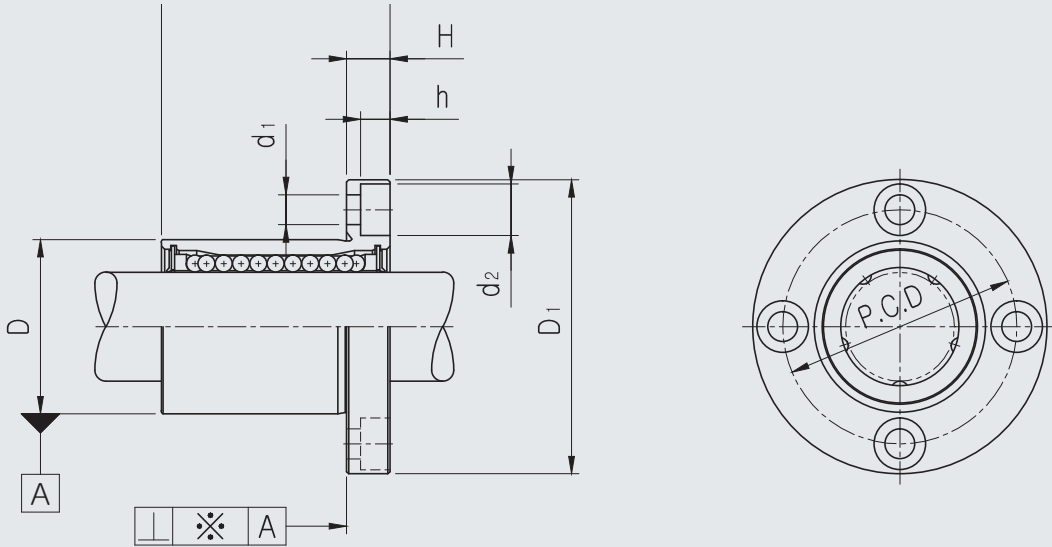

● Part Number Notation

LMF 20 UU - A N S



- SAMICK Circular Flanged Linear Bushing
- Nominal Shaft Diameter
- Seal

Blank	No Seal
UU	Both Side Seal
U	One Side Seal

- Retainer (material)

Blank	Resin Retainer(Standard)
A	Steel Retainer(High temperature) ^{★1}

- Outer-sleeves (by corrosion resistance)

Blank	Standard(SUJ2)
N	Electroless nickel plating
R	Raydent treatment

- Ball type (material)

Blank	Standard(High Carbon Chromium Bearing Steel Ball)
S	Stainless steel ball

★1 Steel retainer available from LMF06 to LMF30 only (LMF08S available with resin retainer only)

LMF FLANGED LINEAR BUSHING

PART NUMBER		WORKING BORE DIAMETER		D		L		D ₁		H	PCD	d ₁	d ₂	h	SQUAR ENESS ※(μm)	BASIC LOAD RATING(N)		NO. OF BALL ROW	WEIGHT (gf) ^{★2}
Resin	Steel ^{★5}	dr. (mm)	Tolerance (mm)	mm	Tolerance (mm)	mm	Tolerance (mm)	mm	Tolerance (mm)							DYNAMIC (C) ^{★1}	STATIC (Co)		
LMF06UU	LMF06-A	6		12		19		28		5	20	3.4	6.5	3.2	12	220	260	4	26.5
LMF08SUU		8		15	0 -0.011	17		32		5	24	3.4	6.5	3.2	12	170	220	4	34
LMF08UU	LMF08-A	8		15		24		32		5	24	3.4	6.5	3.2	12	260	400	4	40
LMF10UU	LMF10-A	10	0 -0.009	19		29	±0.2	40		6	29	4.5	8.0	4.2	12	370	540	4	78
LMF12UU	LMF12-A	12		21	0 -0.013	30		42		6	32	4.5	8.0	4.2	12	410	590	4	76
LMF13UU	LMF13-A	13		23		32		43	0 -0.2	6	33	4.5	8.0	4.2	12	500	770	4	94
LMF16UU	LMF16-A	16		28		37		48		6	38	4.5	8.0	4.2	12	770	1,170	5	134
LMF20UU	LMF20-A	20		32		42		54		8	43	5.5	9.5	5.2	15	860	1,370	5	180
LMF25UU	LMF25-A	25	0 -0.010	40	0 -0.016	59		62		8	51	5.5	9.5	5.2	15	980	1,560	6	340
LMF30UU	LMF30-A	30		45		64		74		10	60	6.6	11.0	6.5	15	1,560	2,740	6	460
LMF35UU		35		52		70		82		10	67	6.6	11.0	6.5	20	1,660	3,130	6	795
LMF40UU		40	0 -0.012	60	0 -0.019	80	±0.3	96		13	78	9.0	14.0	8.6	20	2,150	4,010	6	1,054
LMF50UU		50		80		100		116		13	98	9.0	14.0	8.6	20	3,820	7,930	6	2,200
LMF60UU		60	0 -0.015	90	0 -0.022	110		134	0 -0.3	18	112	11.0	17.5	10.8	25	4,700	9,990	6	2,960
LMF80UU		80		120		140		164		18	142	11.0	17.5	11.1	25	10,130	12,000	6	5,400

- ★1 Dynamic load rating is based on the nominal life of 50km
- ★2 Based on the weight of resin retainer
- ★3 Main unit : mm
- ★4 1N ≒ 0.102kgf
- ★5 Steel retainer available from LMF06 to LMF30 only
(LMF08S available with resin retainer only)

LMF_L FLANGED LONG LINEAR BUSHING

● Drawing

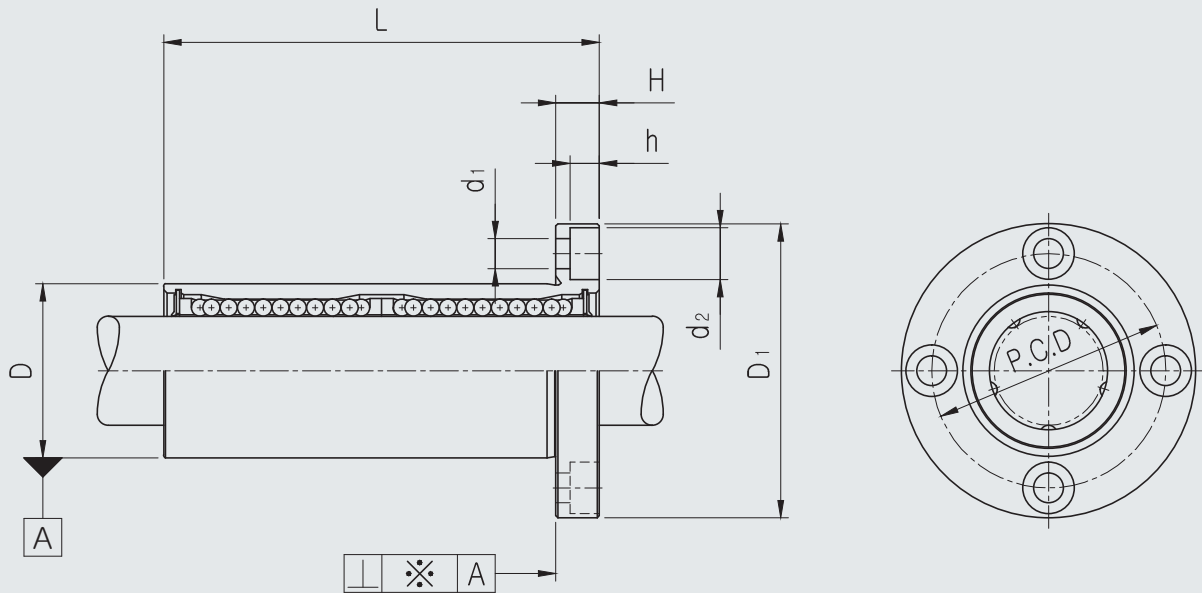

● Part Number Notation

LMF 20 L UU - A N S

- SAMICK Circular Flanged Linear Bushing
- Nominal Shaft Diameter
- Linear Bushing Long Type (for high load)
- Seal

Blank	No Seal
UU	Both Side Seal
U	One Side Seal

- Retainer (material)

Blank	Resin Retainer(Standard)
A	Steel Retainer(High temperature) ★1

- Outer-sleeves (by corrosion resistance)

Blank	Standard(SUJ2)
N	Electroless nickel plating
R	Raydent treatment

- Ball type (material)

Blank	Standard(High Carbon Chromium Bearing Steel Ball)
S	Stainless steel ball



★1 Steel retainer available from LMF06L to LMF30L only

LMF_L FLANGED LONG LINEAR BUSHING

PART NUMBER		WORKING BORE DIAMETER		D		L		D ₁		H	PCD	d ₁	d ₂	h	SQUAR ENESS ※(μm)	BASIC LOAD RATING(N)		NO. OF BALL ROW	WEIGHT (gf) ^{★2}		
Resin	Steel ^{★5}	dr. (mm)	Tolerance (mm)	mm	Tolerance (mm)	mm	Tolerance (mm)	mm	Tolerance (mm)							DYNAMIC (C) ^{★1}	STATIC (Co)				
LMF06LUU	LMF06L-A	6	0 -0.010	12	0 -0.013	35	±0.3	28	0 -0.2	5	20	3.4	6.5	3.2	15	320	520	4	31		
LMF08LUU	LMF08L-A	8		15		45		32		5	24	3.4	6.5	3.2	15	430	780	4	53		
LMF10LUU	LMF10L-A	10		19		55		40		6	29	4.5	8.0	4.2	15	580	1,100	4	105		
LMF12LUU	LMF12L-A	12		21	57	42		6		32	4.5	8.0	4.2	15	650	1,200	4	100			
LMF13LUU	LMF13L-A	13		23	61	43		6		33	4.5	8.0	4.2	15	810	1,570	4	130			
LMF16LUU	LMF16L-A	16		28	70	48		6		38	4.5	8.0	4.2	15	1,230	2,350	5	187			
LMF20LUU	LMF20L-A	20	0 -0.012	32	0 -0.019	80	±0.4	54	0 -0.3	8	43	5.5	9.5	5.2	20	1,400	2,750	5	260		
LMF25LUU	LMF25L-A	25		40		112		62		8	51	5.5	9.5	5.2	20	1,560	3,140	6	515		
LMF30LUU	LMF30L-A	30		45		123		74		10	60	6.6	11.0	6.5	20	2,490	5,490	6	655		
LMF35LUU		35		52		135		82		10	67	6.6	11.0	6.5	25	2,650	6,470	6	970		
LMF40LUU		40		0 -0.015		60		0 -0.022		154	96	13	78	9.0	14.0	8.6	25	3,430	8,040	6	1,560
LMF50LUU		50		80		192		116		13	98	9.0	14.0	8.6	25	6,080	15,900	6	3,500		
LMF60LUU		60	0 -0.020	90	0 -0.025	211	134	18	112	11.0	17.5	10.8	30	7,650	20,000	6	4,500				

★1 Dynamic load rating is based on the nominal life of 50km

★2 Based on the weight of resin retainer

★3 Main unit : mm

★4 1N ≒ 0.102kgf

★5 Steel retainer available from LMF06L to LMF30L only

LMK FLANGED LINEAR BUSHING

● Drawing

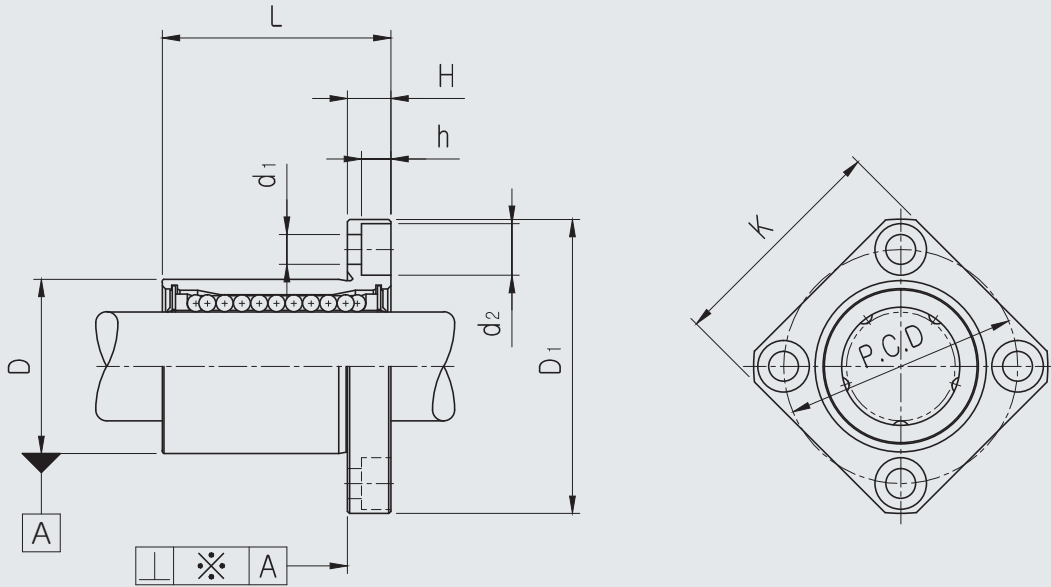

● Part Number Notation

LMK 20 UU - A N S

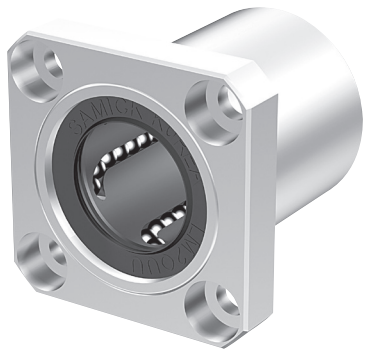

- SAMICK Square Flanged Linear Bushing
- Nominal Shaft Diameter
- Seal

Blank	No Seal
UU	Both Side Seal
U	One Side Seal

- Retainer (material)

Blank	Resin Retainer(Standard)
A	Steel Retainer(High temperature) ^{★1}

- Outer-sleeves (by corrosion resistance)

Blank	Standard(SUJ2)
N	Electroless nickel plating
R	Raydent treatment

- Ball type (material)

Blank	Standard(High Carbon Chromium Bearing Steel Ball)
S	Stainless steel ball

★1 Steel retainer available from LMK06 to LMK30 only
(LMK08S available with resin retainer only)

LMK FLANGED LINEAR BUSHING

PART NUMBER		WORKING BORE DIAMETER		D		L		D ₁		H	PCD	K	d ₁	d ₂	h	SQUAR ENESS ※(μm)	BASIC LOAD RATING(N)		NO. OF BALL ROW	WEIGHT (gf) ^{*2}
Resin	Steel ^{*5}	dr. (mm)	Tolerance (mm)	mm	Tolerance (mm)	mm	Tolerance (mm)	mm	Tolerance (mm)								DYNAMIC (C) ^{*1}	STATIC (Co)		
LMK06UU	LMK06-A	6		12		19		28		5	20	22	3.4	6.5	3.2	12	200	260	4	26.5
LMK08SUU		8		15	0 -0.011	17		32		5	24	25	3.4	6.5	3.2	12	170	220	4	34
LMK08UU	LMK08-A	8		15		24		32		5	24	25	3.4	6.5	3.2	12	260	400	4	40
LMK10UU	LMK10-A	10	0 -0.009	19		29		40		6	29	30	4.5	8.0	4.2	12	370	540	4	78
LMK12UU	LMK12-A	12		21	0 -0.013	30	±0.2	42		6	32	32	4.5	8.0	4.2	12	410	590	4	76
LMK13UU	LMK13-A	13		23		32		43	0 -0.2	6	33	34	4.5	8.0	4.2	12	500	770	4	94
LMK16UU	LMK16-A	16		28		37		48		6	38	37	4.5	8.0	4.2	12	770	1,170	5	134
LMK20UU	LMK20-A	20		32		42		54		8	43	42	5.5	9.5	5.2	15	860	1,370	5	180
LMK25UU	LMK25-A	25	0 -0.010	40	0 -0.016	59		62		8	51	50	5.5	9.5	5.2	15	980	1,560	6	340
LMK30UU	LMK30-A	30		45		64		74		10	60	58	6.6	11.0	6.5	15	1,560	2,740	6	460
LMK35UU		35		52		70		82		10	67	64	6.6	11.0	6.5	20	1,660	3,130	6	795
LMK40UU		40	0 -0.012	60	0 -0.019	80	±0.3	96		13	78	75	9.0	14.0	8.6	20	2,150	4,010	6	1,054
LMK50UU		50		80		100		116		13	98	92	9.0	14.0	8.6	20	3,820	7,930	6	2,200
LMK60UU		60	0 -0.015	90	0 -0.022	110		134	0 -0.3	18	112	106	11.0	17.5	10.8	25	4,700	9,990	6	2,960
LMK80UU		80		120		140		164		18	142	136	11.0	17.5	11.1	25	10,130	12,000	6	4,900

- ★1 Dynamic load rating is based on the nominal life of 50km
- ★2 Based on the weight of resin retainer
- ★3 Main unit : mm
- ★4 1N ≒ 0.102kgf
- ★5 Steel retainer available from LMK06 to LMK30 only
(LMK08S available with resin retainer only)

LMK_L FLANGED LONG LINEAR BUSHING

● Drawing

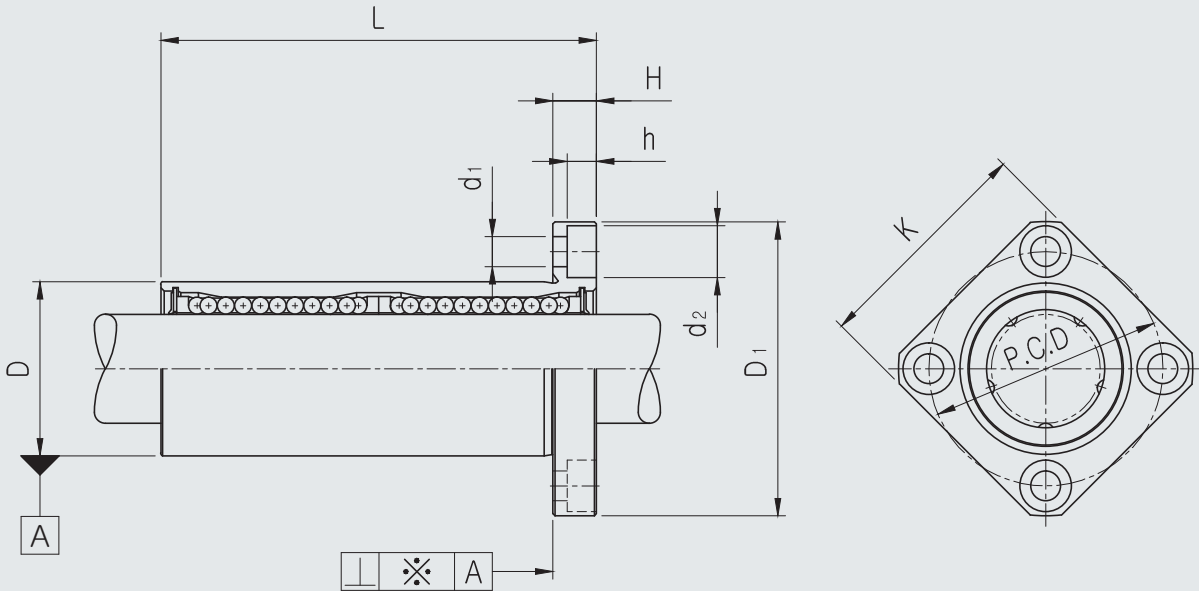

● Part Number Notation

LMK 20 L UU - A N S

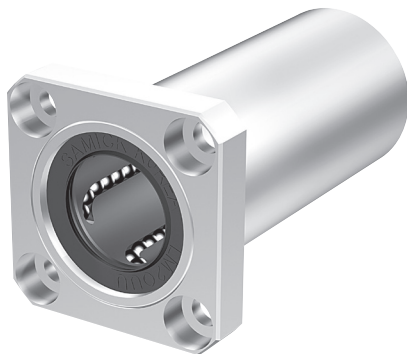

- SAMICK Square Linear Bushing
- Nominal Shaft Diameter
- Linear Bushing Long Type (for high load)
- Seal

Blank	No Seal
UU	Both Side Seal
U	One Side Seal

- Retainer (material)

Blank	Resin Retainer(Standard)
A	Steel Retainer(High temperature) ^{★1}

- Outer-sleeves (by corrosion resistance)

Blank	Standard(SUJ2)
N	Electroless nickel plating
R	Raydent treatment

- Ball type (material)

Blank	Standard(High Carbon Chromium Bearing Steel Ball)
S	Stainless steel ball

★1 Steel retainer available from LMK06L to LMK30L only

LMK_L FLANGED LONG LINEAR BUSHING

PART NUMBER		WORKING BORE DIAMETER		D		L		D ₁		H	PCD	K	d ₁	d ₂	h	SQUAR ENESS ※(μm)	BASIC LOAD RATING(N)		NO. OF BALL ROW	WEIGHT (gf) ^{★2}			
Resin	Steel ^{★5}	dr. (mm)	Tolerance (mm)	mm	Tolerance (mm)	mm	Tolerance (mm)	mm	Tolerance (mm)								DYNAMIC (C) ^{★1}	STATIC (Co)					
LMK06LUU	LMK06L-A	6	0 -0.010	12	0 -0.013	35	±0.3	28	0 -0.2	5	20	22	3.4	6.5	3.2	15	320	520	4	31			
LMK08LUU	LMK08L-A	8		15		45		32		5	24	25	3.4	6.5	3.2	15	430	780	4	53			
LMK10LUU	LMK10L-A	10		19	55	40		6		29	30	4.5	8.0	4.2	15	580	1,100	4	105				
LMK12LUU	LMK12L-A	12		21	0 -0.016	57		42		6	32	32	4.5	8.0	4.2	15	650	1,200	4	100			
LMK13LUU	LMK13L-A	13		23		61		43		6	33	34	4.5	8.0	4.2	15	810	1,570	4	130			
LMK16LUU	LMK16L-A	16		28	70	48		6		38	37	4.5	8.0	4.2	15	1,230	2,350	5	187				
LMK20LUU	LMK20L-A	20		32	80	54		8		43	42	5.5	9.5	5.2	20	1,400	2,750	5	260				
LMK25LUU	LMK25L-A	25		0 -0.012	40	0 -0.019		112		±0.4	62	0 -0.3	8	51	50	5.5	9.5	5.2	20	1,560	3,140	6	515
LMK30LUU	LMK30L-A	30			45			123			74		10	60	58	6.6	11.0	6.5	20	2,490	5,490	6	655
LMK35LUU		35		52	135	82		10		67	64	6.6	11.0	6.5	25	2,650	6,470	6	970				
LMK40LUU		40	0 -0.015	60	0 -0.022	154	±0.4	96	0 -0.3	13	78	75	9.0	14.0	8.6	25	3,430	8,040	6	1,560			
LMK50LUU		50		80		192		116		13	98	92	9.0	14.0	8.6	25	6,080	15,900	6	3,500			
LMK60LUU		60	0 -0.020	90	0 -0.025	211		134		18	112	106	11.0	17.5	10.8	30	7,650	20,000	6	4,500			

- ★1 Dynamic load rating is based on the nominal life of 50km
- ★2 Based on the weight of resin retainer
- ★3 Main unit : mm
- ★4 1N ≒ 0.102kgf
- ★5 Steel retainer available from LMK06L to LMK30L only

LMH FLANGED LINEAR BUSHING

● Drawing

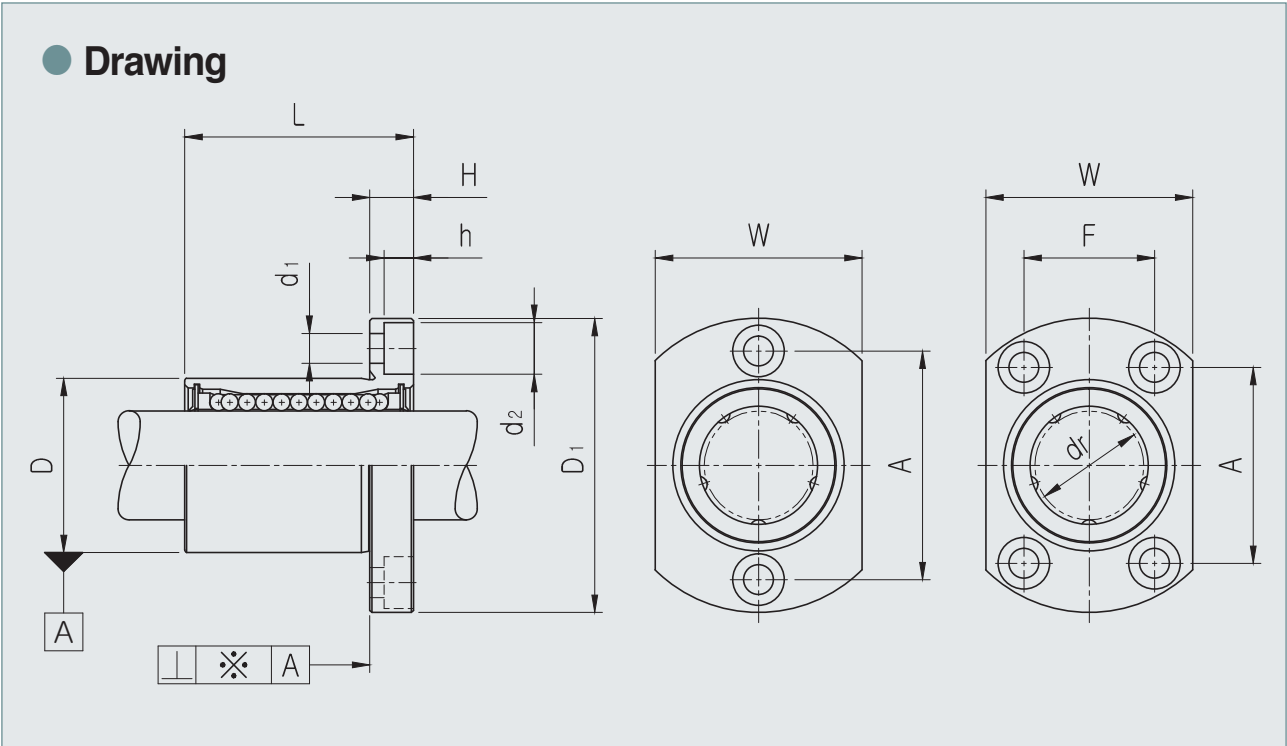

● Part Number Notation

LMH 20 UU - A N S

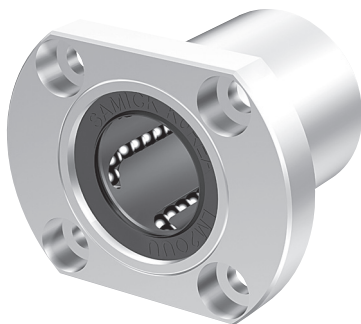

- SAMICK Oval Flanged Linear Bushing
- Nominal Shaft Diameter
- Seal

Blank	No Seal
UU	Both Side Seal
U	One Side Seal

- Retainer (material)

Blank	Resin Retainer(Standard)
A	Steel Retainer(High temperature)*1

- Outer-sleeves (by corrosion resistance)

Blank	Standard(SUJ2)
N	Electroless nickel plating
R	Raydent treatment

- Ball type (material)

Blank	Standard(High Carbon Chromium Bearing Steel Ball)
S	Stainless steel ball

*1 Steel retainer available from LMH06 to LMH30 only

LMH FLANGED LINEAR BUSHING

PART NUMBER		WORKING BORE DIAMETER		D		L		D ₁		H	W	A	F	d ₁	d ₂	h	SQUAR ENESS ※(μm)	BASIC LOAD RATING(N)		NO. OF BALL ROW	WEIGHT (gf) ^{★2}			
Resin	Steel ^{★5}	dr. (mm)	Tolerance (mm)	mm	Tolerance (mm)	mm	Tolerance (mm)	mm	Tolerance (mm)									DYNAMIC (C) ^{★1}	STATIC (Co)					
LMH06UU	LMH06-A	6	0 -0.09	12	0 -0.011	19	±0.2	28	0 -0.2	5	18	20	-	3.4	6.5	3.2	12	200	260	4	26.5			
LMH08UU	LMH08-A	8		15		24		32		5	21	24	-	3.4	6.5	3.2	12	260	400	4	40			
LMH10UU	LMH10-A	10		19	29	40		6		25	29	-	4.5	8.0	4.2	12	370	540	4	78				
LMH12UU	LMH12-A	12		21	0 -0.013	30		42		6	27	32	-	4.5	8.0	4.2	12	410	590	4	76			
LMH13UU	LMH13-A	13		23		32		43		6	29	33	-	4.5	8.0	4.2	12	500	770	4	94			
LMH16UU	LMH16-A	16		28		37		48		6	34	31	22	4.5	8.0	4.2	12	770	1,170	5	134			
LMH20UU	LMH20-A	20		32	42	54		8		38	36	24	5.5	9.5	5.2	15	860	1,370	5	180				
LMH25UU	LMH25-A	25		0 -0.010	40	0 -0.016		59		±0.3	62		8	46	40	32	5.5	9.5	5.2	15	980	1,560	6	340
LMH30UU	LMH30-A	30			45			64			74		10	51	49	35	6.6	11.0	6.5	15	1,560	2,740	6	460

★1 Dynamic load rating is based on the nominal life of 50km

★2 Based on the weight of resin retainer

★3 Main unit : mm

★4 1N ≒ 0.102kgf

★5 Steel retainer available from LMH06 to LMH30 only

LMH_L FLANGED LONG LINEAR BUSHING

● Drawing

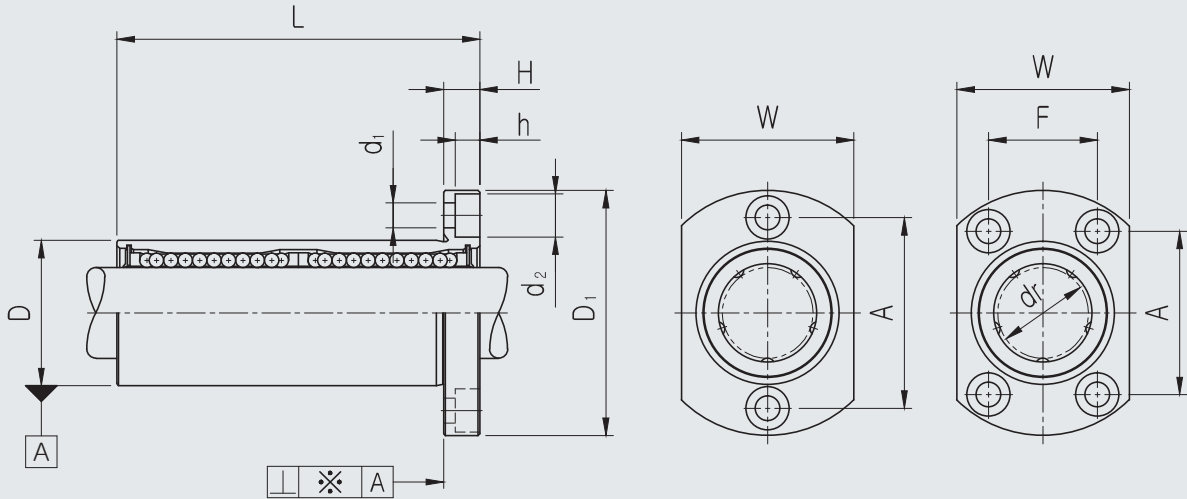

● Part Number Notation

LMH 20 L UU - A N S

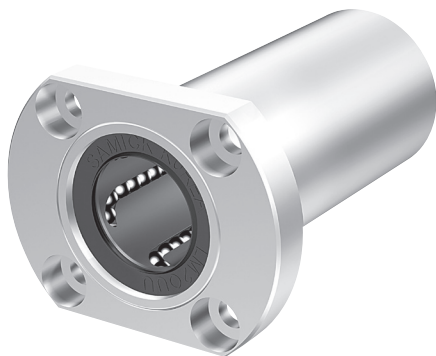

- SAMICK Oval Flanged Linear Bushing
- Nominal Shaft Diameter
- Linear Bushing Long Type (for high load)
- Seal

Blank	No Seal
UU	Both Side Seal
U	One Side Seal

- Retainer (material)

Blank	Resin Retainer(Standard)
A	Steel Retainer(High temperature) ^{★1}

- Outer-sleeves (by corrosion resistance)

Blank	Standard(SUJ2)
N	Electroless nickel plating
R	Raydent treatment

- Ball type (material)

Blank	Standard(High Carbon Chromium Bearing Steel Ball)
S	Stainless steel ball

★1 Steel retainer available from LMH06L to LMH30L only

LMH_L FLANGED LONG LINEAR BUSHING

PART NUMBER		WORKING BORE DIAMETER		D		L		D ₁		H	W	A	F	d ₁	d ₂	h	SQUAREDNESS *(μm)	BASIC LOAD RATING(N)		NO. OF BALL ROW	WEIGHT (gf) ^{*2}
Resin	Steel ^{*5}	dr. (mm)	Tolerance (mm)	mm	Tolerance (mm)	mm	Tolerance (mm)	mm	Tolerance (mm)									DYNAMIC (C) ^{*1}	STATIC (Co)		
LMH06LUU	LMH06L-A	6	0 -0.010	12	0 -0.013	35	±0.3	28	0 -0.2	5	18	20	-	3.4	6.5	3.2	15	320	520	4	31
LMH08LUU	LMH08L-A	8		15		45		32		5	21	24	-	3.4	6.5	3.2	15	430	780	4	53
LMH10LUU	LMH10L-A	10		19	55	40		6		25	29	-	4.5	8.0	4.2	15	580	1,100	4	105	
LMH12LUU	LMH12L-A	12		21	0 -0.016	57		42		6	27	32	-	4.5	8.0	4.2	15	650	1,200	4	100
LMH13LUU	LMH13L-A	13		23		61		43		6	29	33	-	4.5	8.0	4.2	15	810	1,570	4	130
LMH16LUU	LMH16L-A	16		28		70		48		6	34	31	22	4.5	8.0	4.2	15	1,230	2,350	5	187
LMH20LUU	LMH20L-A	20		32	80	54		8		38	36	24	5.5	9.5	5.2	20	1,400	2,750	5	260	
LMH25LUU	LMH25L-A	25		0 -0.012	40	0 -0.019		112		±0.4	62		8	46	40	32	5.5	9.5	5.2	20	1,560
LMH30LUU	LMH30-A	30	45		123		74	10	51		49		35	6.6	11.0	6.5	20	2,490	5,490	6	655

★1 Dynamic load rating is based on the nominal life of 50km

★2 Based on the weight of resin retainer

★3 Main unit : mm

★4 1N ≒ 0.102kgf

★5 Steel retainer available from LMH06L to LMH30L only

LMFP FLANGED LINEAR BUSHING

● Drawing

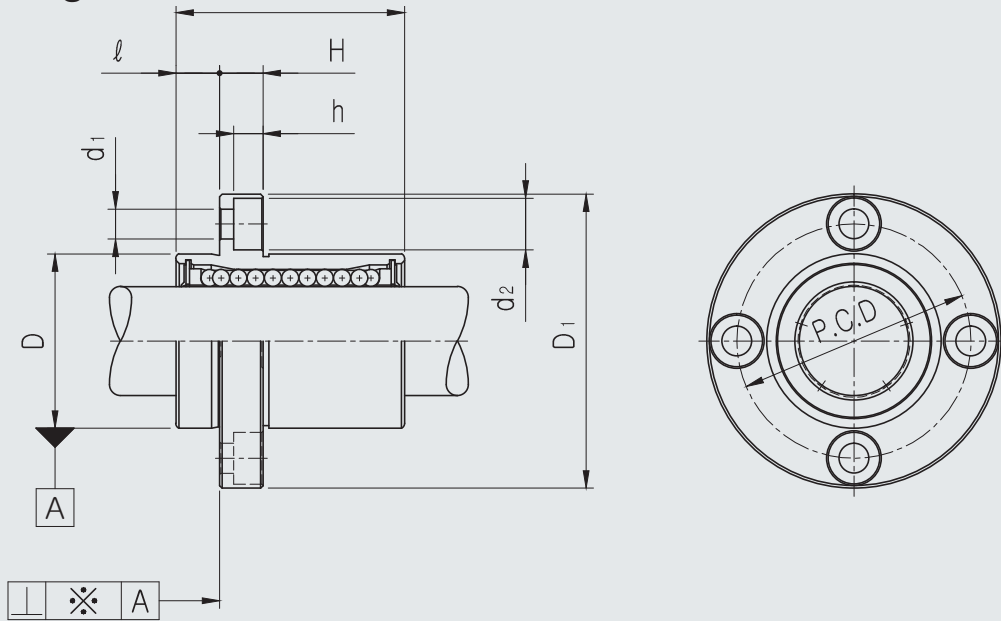

● Part Number Notation

LMFP 20 UU - A N S



- SAMICK Circular Pilot Flanged Linear Bushing
- Nominal Shaft Diameter
- Seal

Blank	No Seal
UU	Both Side Seal
U	One Side Seal

- Retainer (material)

Blank	Resin Retainer(Standard)
A	Steel Retainer(High temperature) ^{★1}

- Outer-sleeves (by corrosion resistance)

Blank	Standard(SUJ2)
N	Electroless nickel plating
R	Raydent treatment

- Ball type (material)

Blank	Standard(High Carbon Chromium Bearing Steel Ball)
S	Stainless steel ball

★1 Steel retainer available from LMFP06 to LMFP30 only

LMFP FLANGED LINEAR BUSHING

PART NUMBER		WORKING BORE DIAMETER		D		L		D ₁		ℓ	H	PCD	d ₁	d ₂	h	SQUAR ENESS *(μm)	BASIC LOAD RATING(N)		NO. OF BALL ROW	WEIGHT (gf) ^{*2}			
Resin	Steel ^{*5}	dr. (mm)	Tolerance (mm)	mm	Tolerance (mm)	mm	Tolerance (mm)	mm	Tolerance (mm)								DYNAMIC (C) ^{*1}	STATIC (Co)					
LMFP06UU	LMFP06-A	6	0 -0.009	12	0 -0.011	19	±0.2	28	0 -0.2	5	5	20	3.4	6.5	3.2	12	200	260	4	26.5			
LMFP08UU	LMFP08-A	8		15		24		32		5	5	24	3.4	6.5	3.2	12	260	400	4	40			
LMFP10UU	LMFP10-A	10		19	29	40		6		6	29	4.5	8	4.2	12	370	540	4	76				
LMFP12UU	LMFP12-A	12		21	30	42		6		6	32	4.5	8	4.2	12	410	590	4	78				
LMFP13UU	LMFP13-A	13		23	32	43		6		6	33	4.5	8	4.2	12	500	770	4	94				
LMFP16UU	LMFP16-A	16		28	37	48		6		6	38	4.5	8	4.2	12	770	1,170	5	134				
LMFP20UU	LMFP20-A	20		32	42	54		8		8	43	5.5	9.5	5.2	15	860	1,370	5	180				
LMFP25UU	LMFP25-A	25		0 -0.010	40	0 -0.016		59		±0.3	62	0 -0.3	8	8	51	5.5	9.5	5.2	15	980	1,560	6	340
LMFP30UU	LMFP30-A	30		45	64	74		10			10		60	6.6	11	6.5	15	1,560	2,740	6	460		
LMFP35UU		35		52	70	82		10			10		67	6.6	11	6.5	20	1,660	3,130	6	795		
LMFP40UU		40	0 -0.012	60	0 -0.019	80	96	13	13		78		9	14	8.6	20	2,150	4,010	6	1,054			
LMFP50UU		50	80	100	116	13	13	98	9		14		8.6	20	3,820	7,930	6	2,200					
LMFP60UU		60	0 -0.015	90	0 -0.022	110	134	18	18		112		11	17.5	10.8	25	4,700	9,990	6	2,960			

- ★1 Dynamic load rating is based on the nominal life of 50km
- ★2 Based on the weight of resin retainer
- ★3 Main unit : mm
- ★4 1N ≒ 0.102kgf
- ★5 Steel retainer available from LMFP06 to LMFP30 only

LMFP_L FLANGED LONG LINEAR BUSHING

● Drawing

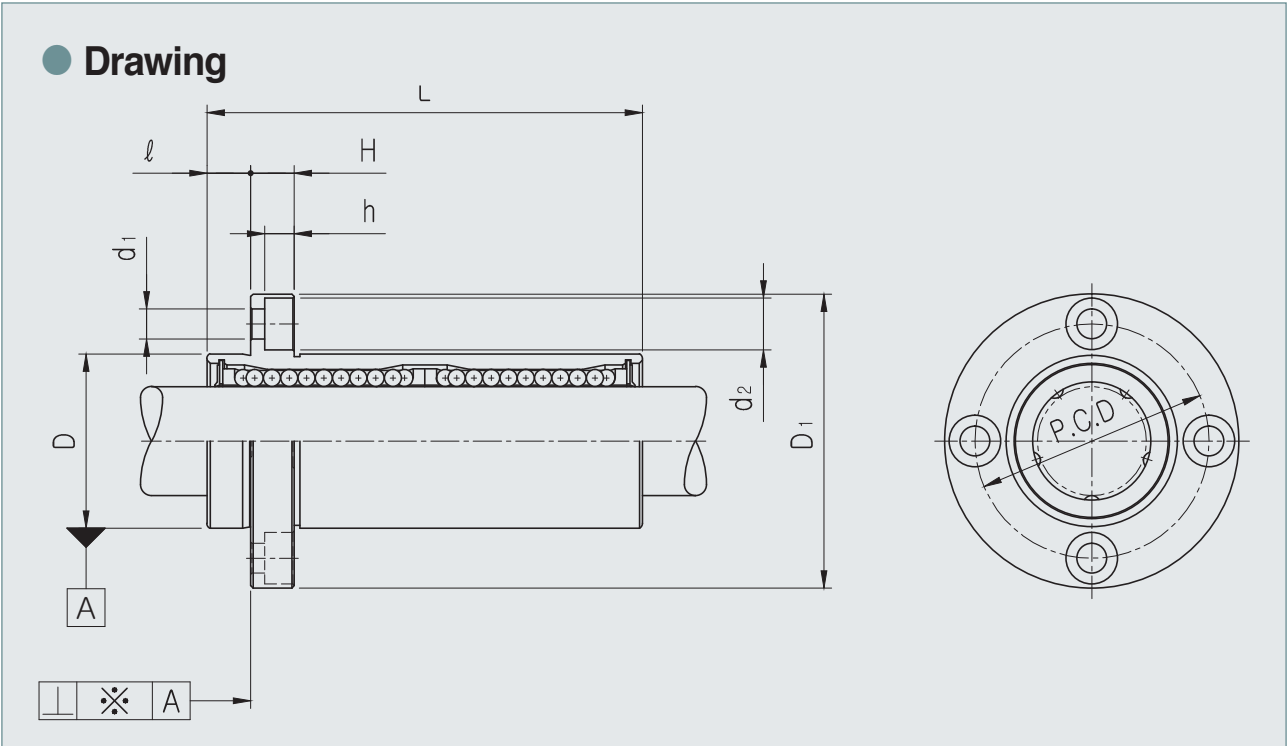

● Part Number Notation

LMFP 20 L UU - A N S



- SAMICK Circular Flanged Linear Bushing
- Nominal Shaft Diameter
- Linear Bushing Long Type (for high load)
- Seal

Blank	No Seal
UU	Both Side Seal
U	One Side Seal

- Retainer (material)

Blank	Resin Retainer(Standard)
A	Steel Retainer(High temperature) ^{★1}

- Outer-sleeves (by corrosion resistance)

Blank	Standard(SUJ2)
N	Electroless nickel plating
R	Raydent treatment

- Ball type (material)

Blank	Standard(High Carbon Chromium Bearing Steel Ball)
S	Stainless steel ball

★1 Steel retainer available from LMFP06L to LMFP30L only

LMFP_L FLANGED LONG LINEAR BUSHING

PART NUMBER		WORKING BORE DIAMETER		D		L		D ₁		ℓ	H	PCD	d ₁	d ₂	h	SQUAR ENESS ※(μm)	BASIC LOAD RATING(N)		NO. OF BALL ROW	WEIGHT (gf) ^{★2}	
Resin	Steel ^{★5}	dr. (mm)	Tolerance (mm)	mm	Tolerance (mm)	mm	Tolerance (mm)	mm	Tolerance (mm)								DYNAMIC (C) ^{★1}	STATIC (Co)			
LMFP06LUU	LMFP6L-A	6	0 -0.010	12	0 -0.013	35	0 -0.3	28	0 -0.2	5	5	20	3.4	6.5	3.2	15	320	520	4	31	
LMFP08LUU	LMFP8L-A	8		15		45		32		5	5	24	3.4	6.5	3.2	15	430	780	4	53	
LMFP10LUU	LMFP10L-A	10		19	55	40		6		6	29	4.5	8	4.2	15	580	1,100	4	105		
LMFP12LUU	LMFP12L-A	12		21	0 -0.016	57		42		6	6	32	4.5	8	4.2	15	650	1,200	4	100	
LMFP13LUU	LMFP13L-A	13		23		61				43	6	6	33	4.5	8	4.2	15	810	1,570	4	130
LMFP16LUU	LMFP16L-A	16		28	70	48		6		6	38	4.5	8	4.2	15	1,230	2,350	5	187		
LMFP20LUU	LMFP20L-A	20		32	80	54		8		8	43	5.5	9.5	5.2	20	1,400	2,750	5	260		
LMFP25LUU	LMFP25L-A	25		0 -0.012	40	0 -0.019		112		62	8	8	51	5.5	9.5	5.2	20	1,560	3,140	6	515
LMFP30LUU	LMFP30L-A	30			45			123			74	10	10	60	6.6	11	6.5	20	2,490	5,490	6
LMFP35LUU		35		52	135	82		10		10	67	6.6	11	6.5	25	2,650	6,470	6	970		
LMFP40LUU		40	0 -0.015	60	0 -0.022	154	96	13	13	78	9	14	8.6	25	3,430	8,040	6	1,560			
LMFP50LUU		50		80		192		116	13	13	98	9	14	8.6	25	6,080	15,900	6	3,500		
LMFP60LUU		60	0 -0.020	90	0 -0.025	211	134	18	18	112	11	17.5	10.8	30	7,650	20,000	6	4,500			

- ★1 Dynamic load rating is based on the nominal life of 50km
- ★2 Based on the weight of resin retainer
- ★3 Main unit : mm
- ★4 1N ≒ 0.102kgf
- ★5 Steel retainer available from LMFP06L to LMFP30L only

LMKP FLANGED LINEAR BUSHING

● Drawing

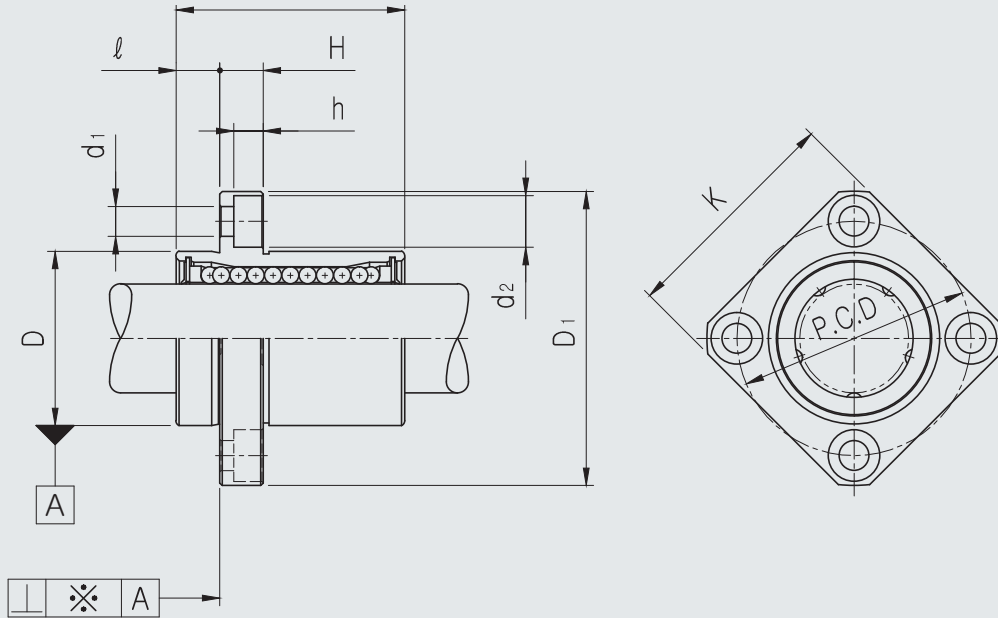

● Part Number Notation

LMKP 20 UU - A N S

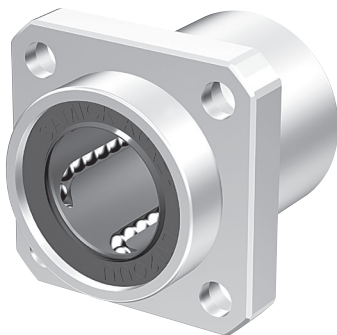

- SAMICK Square Pilot Flanged Linear Bushing
- Nominal Shaft Diameter
- Seal

Blank	No Seal
UU	Both Side Seal
U	One Side Seal

- Retainer (material)

Blank	Resin Retainer(Standard)
A	Steel Retainer(High temperature) ^{★1}

- Outer-sleeves (by corrosion resistance)

Blank	Standard(SUJ2)
N	Electroless nickel plating
R	Raydent treatment

- Ball type (material)

Blank	Standard(High Carbon Chromium Bearing Steel Ball)
S	Stainless steel ball

★1 Steel retainer available from LMKP06 to LMKP30 only

LMKP FLANGED LINEAR BUSHING

PART NUMBER		WORKING BORE DIAMETER		D		L		D ₁		ℓ	H	PCD	K	d ₁	d ₂	h	SQUAREDNESS ※(μm)	BASIC LOAD RATING(N)		NO. OF BALL ROW	WEIGHT (gf) ^{★2}			
Resin	Steel ^{★5}	dr. (mm)	Tolerance (mm)	mm	Tolerance (mm)	mm	Tolerance (mm)	mm	Tolerance (mm)								DYNAMIC (C) ^{★1}	STATIC (Co)						
LMKP06UU	LMKP06-A	6	0 -0.009	12	0 -0.011	19	0 -0.2	28	0 -0.2	5	5	20	22	3.4	6.5	3.2	12	200	260	4	26.5			
LMKP08UU	LMKP08-A	8		15		24		32		5	5	24	25	3.4	6.5	3.2	12	260	400	4	40			
LMKP10UU	LMKP10-A	10		19	29	40		6		6	29	30	4.5	8	4.2	12	370	540	4	76				
LMKP12UU	LMKP12-A	12		21	30	42		6		6	32	32	4.5	8	4.2	12	410	590	4	78				
LMKP13UU	LMKP13-A	13		23	32	43		6		6	33	34	4.5	8	4.2	12	500	770	4	94				
LMKP16UU	LMKP16-A	16		28	37	48		6		6	38	37	4.5	8	4.2	12	770	1,170	5	134				
LMKP20UU	LMKP20-A	20		32	42	54		8		8	43	42	5.5	9.5	5.2	15	860	1,370	5	180				
LMKP25UU	LMKP25-A	25		0 -0.010	40	0 -0.016		59		0 -0.3	62	0 -0.3	8	8	51	50	5.5	9.5	5.2	15	980	1,560	6	340
LMKP30UU	LMKP30-A	30		45	64	74		10			10		60	58	6.6	11	6.5	15	1,560	2,740	6	460		
LMKP35UU		35		52	70	82		10			10		67	64	6.6	11	6.5	20	1,660	3,130	6	795		
LMKP40UU		40	0 -0.012	60	0 -0.019	80	96	13	13		78		75	9	14	8.6	20	2,150	4,010	6	1,054			
LMKP50UU		50	80	100	116	13	13	98	92		9		14	8.6	20	3,820	7,930	6	2,200					
LMKP60UU		60	0 -0.015	90	0 -0.022	110	134	18	18		112		106	11	17.5	10.8	25	4,700	9,990	6	2,960			

- ★1 Dynamic load rating is based on the nominal life of 50km
- ★2 Based on the weight of resin retainer
- ★3 Main unit : mm
- ★4 1N ≒ 0.102kgf
- ★5 Steel retainer available from LMKP06 to LMKP30 only

LMKP_L FLANGED LONG LINEAR BUSHING

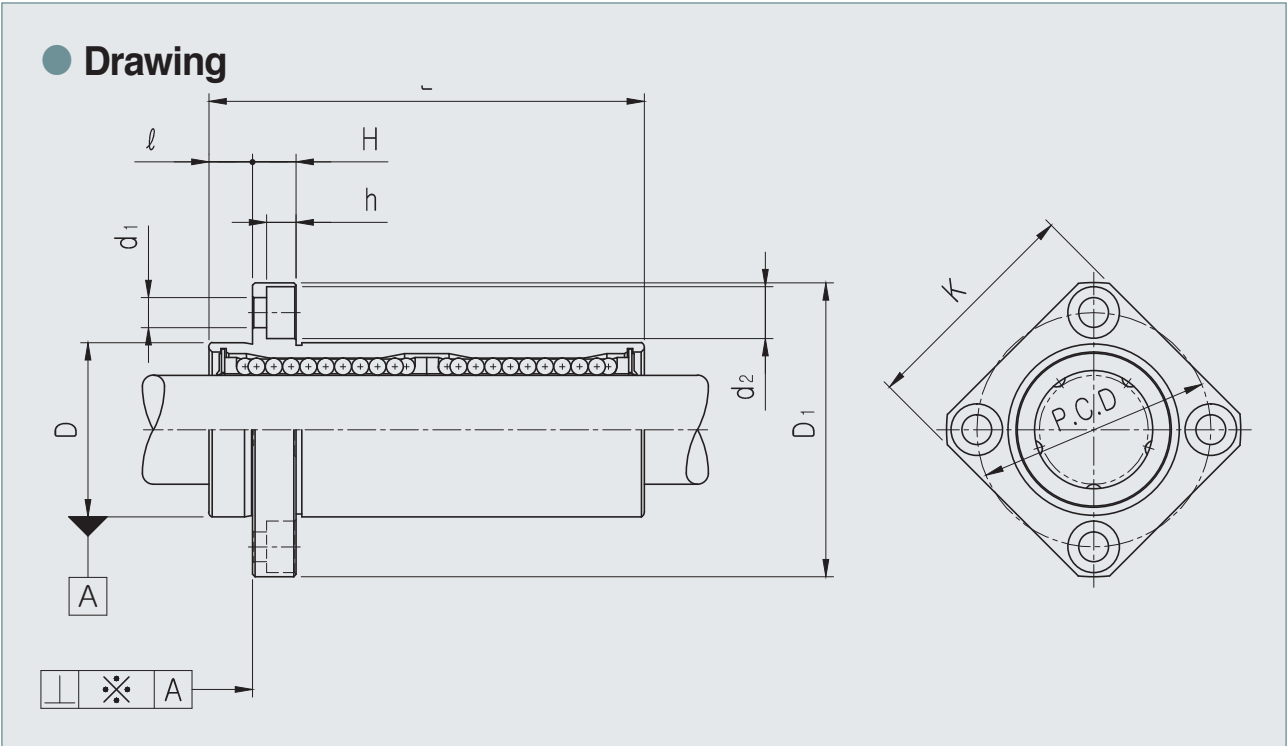

● Part Number Notation

LMKP 20 L UU - A N S

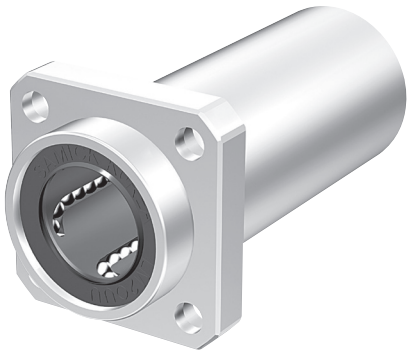

- SAMICK Square Flanged Linear Bushing
- Nominal Shaft Diameter
- Linear Bushing Long Type (for high load)
- Seal

Blank	No Seal
UU	Both Side Seal
U	One Side Seal

- Retainer (material)

Blank	Resin Retainer(Standard)
A	Steel Retainer(High temperature) ^{★1}

- Outer-sleeves (by corrosion resistance)

Blank	Standard(SUJ2)
N	Electroless nickel plating
R	Raydent treatment

- Ball type (material)

Blank	Standard(High Carbon Chromium Bearing Steel Ball)
S	Stainless steel ball

★1 Steel retainer available from LMKP06L to LMKP30L only

LMKP_L FLANGED LONG LINEAR BUSHING

PART NUMBER		WORKING BORE DIAMETER		D		L		D ₁		ℓ	H	PCD	K	d ₁	d ₂	h	SQUARENESSESS ※(μm)	BASIC LOAD RATING(N)		NO. OF BALL ROW	WEIGHT (gf) ^{★2}				
Resin	Steel ^{★5}	dr. (mm)	Tolerance (mm)	mm	Tolerance (mm)	mm	Tolerance (mm)	mm	Tolerance (mm)									DYNAMIC (C) ^{★1}	STATIC (Co)						
LMKP06LUU	LMKP06L-A	6	0 -0.010	12	0 -0.013	35	0 -0.3	28	0 -0.2	5	5	20	22	3.4	6.5	3.2	15	320	520	4	31				
LMKP08LUU	LMKP08L-A	8		15		45		32		5	5	24	25	3.4	6.5	3.2	15	430	780	4	53				
LMKP10LUU	LMKP10L-A	10		19		55		40		6	6	29	30	4.5	8	4.2	15	580	1,100	4	105				
LMKP12LUU	LMKP12L-A	12		21		57		42		6	6	32	32	4.5	8	4.2	15	650	1,200	4	100				
LMKP13LUU	LMKP13L-A	13		23		61		43		6	6	33	34	4.5	8	4.2	15	810	1,570	4	130				
LMKP16LUU	LMKP16L-A	16		28		70		48		6	6	38	37	4.5	8	4.2	15	1,230	2,350	5	187				
LMKP20LUU	LMKP20L-A	20		32		80		54		8	8	43	42	5.5	9.5	5.2	20	1,400	2,750	5	260				
LMKP25LUU	LMKP25L-A	25		0 -0.012		40		0 -0.019		112	0 -0.4	62	0 -0.3	8	8	51	50	5.5	9.5	5.2	20	1,560	3,140	6	515
LMKP30LUU	LMKP30L-A	30		45		123		74		10		10		60	58	6.6	11	6.5	20	2,490	5,490	6	655		
LMKP35LUU		35		52		135		82		10		10		67	64	6.6	11	6.5	25	2,650	6,470	6	970		
LMKP40LUU		40	0 -0.015	60	0 -0.022	154	96	13	13	78		75		9	14	8.6	25	3,430	8,040	6	1,560				
LMKP50LUU		50	80	192	116	13	13	98	92	9		14		8.6	25	6,080	15,900	6	3,500						
LMKP60LUU		60	0 -0.020	90	0 -0.025	211	134	18	18	112		106		11	17.5	10.8	30	7,650	20,000	6	4,500				

- ★1 Dynamic load rating is based on the nominal life of 50km
- ★2 Based on the weight of resin retainer
- ★3 Main unit : mm
- ★4 1N ≒ 0.102kgf
- ★5 Steel retainer available from LMKP06L to LMKP30L only

LMHP FLANGED LINEAR BUSHING

● Drawing

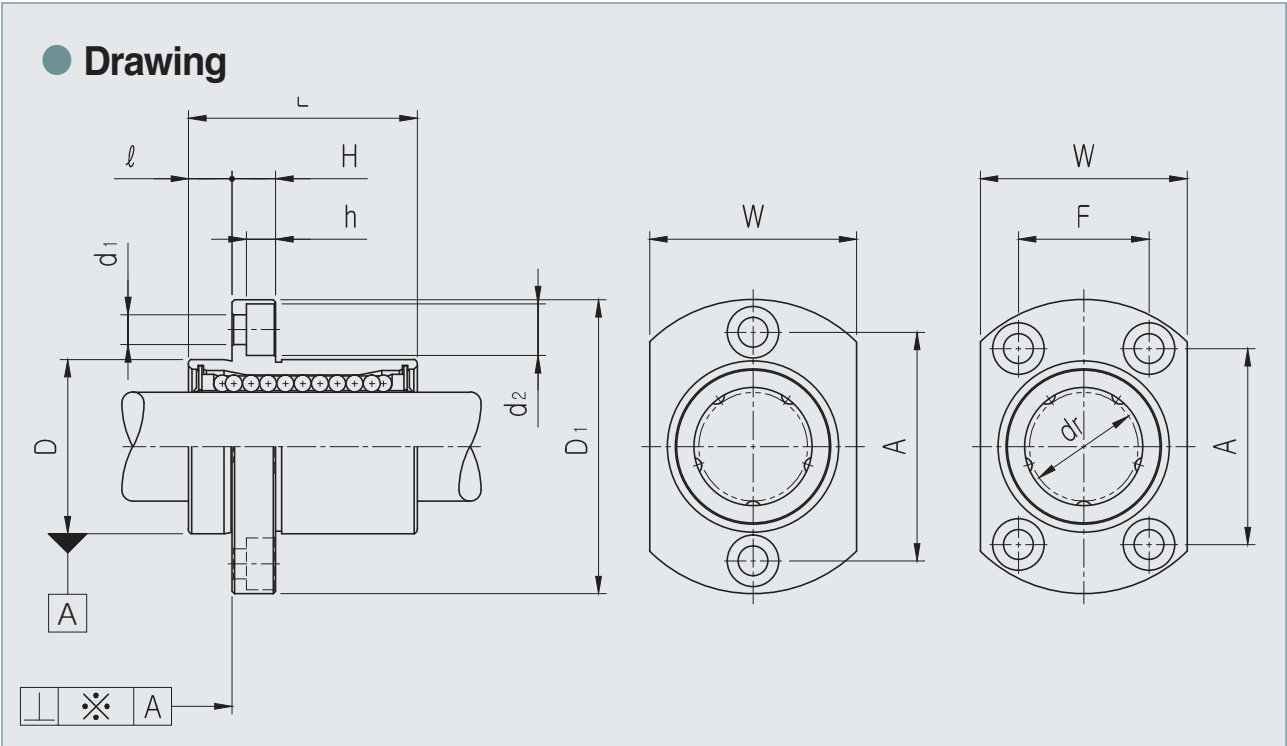

● Part Number Notation

LMHP 20 UU - A N S



- SAMICK Oval Pilot Flanged Linear Bushing
- Nominal Shaft Diameter
- Seal

Blank	No Seal
UU	Both Side Seal
U	One Side Seal

- Retainer (material)

Blank	Resin Retainer(Standard)
A	Steel Retainer(High temperature) ^{★1}

- Outer-sleeves (by corrosion resistance)

Blank	Standard(SUJ2)
N	Electroless nickel plating
R	Raydent treatment

- Ball type (material)

Blank	Standard(High Carbon Chromium Bearing Steel Ball)
S	Stainless steel ball

★1 Steel retainer available from LMHP06 to LMHP30 only

LMHP FLANGED LINEAR BUSHING

PART NUMBER		WORKING BORE DIAMETER		D		L		D ₁		ℓ	H	W	A	F	d ₁	d ₂	h	SQUARENESSE ※(μm)	BASIC LOAD RATING(N)		NO. OF BALL ROW	WEIGHT (gf) ^{★2}			
Resin	Steel ^{★5}	dr. (mm)	Tolerance (mm)	mm	Tolerance (mm)	mm	Tolerance (mm)	mm	Tolerance (mm)									DYNAMIC (C) ^{★1}	STATIC (Co)						
LMHP06UU	LMHP06-A	6	0 -0.009	12	0 -0.011	19	0 -0.2	28	0 -0.2	5	5	18	20		3.4	6.5	3.2	12	200	260	4	26.5			
LMHP08UU	LMHP08-A	8		15		24		32		5	5	21	24		3.4	6.5	3.2	12	260	400	4	40			
LMHP10UU	LMHP10-A	10		19	29	40		6		6	25	29		4.5	8	4.2	12	370	540	4	76				
LMHP12UU	LMHP12-A	12		21	0 -0.013	30		0 -0.2		42	0 -0.2	6	6	27	32		4.5	8	4.2	12	410	590	4	78	
LMHP13UU	LMHP13-A	13		23		32				43		6	6	29	33		4.5	8	4.2	12	500	770	4	94	
LMHP16UU	LMHP16-A	16		28		37				48		6	6	34	31	22	4.5	8	4.2	12	770	1,170	5	134	
LMHP20UU	LMHP20-A	20		32	42	54		8		8	38	36	24	5.5	9.5	5.2	15	860	1,370	5	180				
LMHP25UU	LMHP25-A	25		0 -0.010	40	0 -0.016		59		0 -0.3	62	0 -0.3	8	8	46	40	32	5.5	9.5	5.2	15	980	1,560	6	340
LMHP30UU	LMHP30-A	30			45			64			74		10	10	51	49	35	6.6	11	6.5	15	1,560	2,740	6	460

★1 Dynamic load rating is based on the nominal life of 50km

★2 Based on the weight of resin retainer

★3 Main unit : mm

★4 1N ≒ 0.102kgf

★5 Steel retainer available from LMHP06 to LMHP30 only

LMHP_L FLANGED LONG LINEAR BUSHING

● Drawing

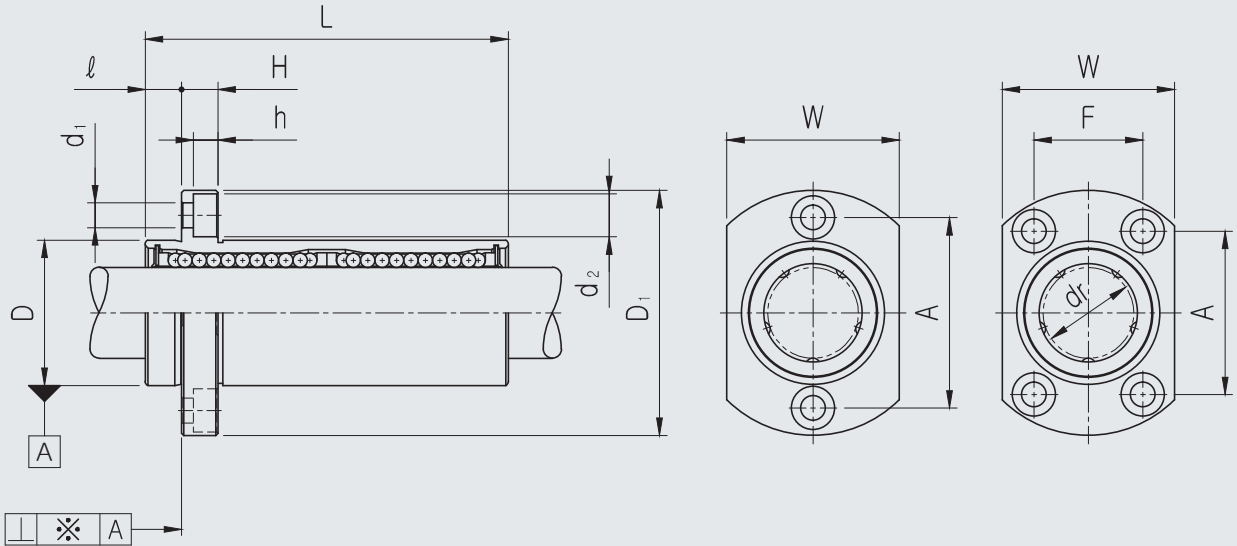

● Part Number Notation

LMHP 20 L UU - A N S

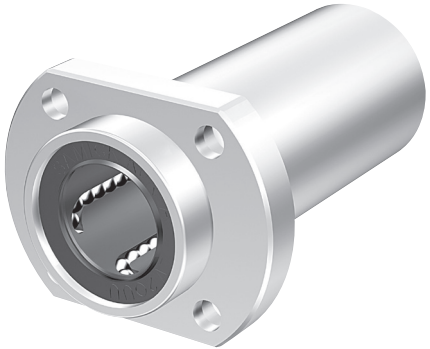

- SAMICK Oval Flanged Linear Bushing
- Nominal Shaft Diameter
- Linear Bushing Long Type (for high load)
- Seal

Blank	No Seal
UU	Both Side Seal
U	One Side Seal

- Retainer (material)

Blank	Resin Retainer(Standard)
A	Steel Retainer(High temperature) ^{★1}

- Outer-sleeves (by corrosion resistance)

Blank	Standard(SUJ2)
N	Electroless nickel plating
R	Raydent treatment

- Ball type (material)

Blank	Standard(High Carbon Chromium Bearing Steel Ball)
S	Stainless steel ball

★1 Steel retainer available from LMHP06L to LMHP30L only

LMHP_L FLANGED LONG LINEAR BUSHING

PART NUMBER		WORKING BORE DIAMETER		D		L		D ₁		ℓ	H	W	A	F	d ₁	d ₂	h	SQUAR ENESS ※(μm)	BASIC LOAD RATING(N)		NO. OF BALL ROW	WEIGHT (g) ^{★2}			
Resin	Steel ^{★5}	dr. (mm)	Tolerance (mm)	mm	Tolerance (mm)	mm	Tolerance (mm)	mm	Tolerance (mm)									DYNAMIC (C) ^{★1}	STATIC (Co)						
LMHP06LUU	LMHP06L-A	6	0 -0.010	12	0 -0.013	35	0 -0.3	28	0 -0.2	5	5	18	20		3.4	6.5	3.2	15	320	520	4	31			
LMHP08LUU	LMHP08L-A	8		15		45		32		5	5	21	24		3.4	6.5	3.2	15	430	780	4	53			
LMHP10LUU	LMHP10L-A	10		19	55	40		6		6	25	29		4.5	8	4.2	15	580	1,100	4	105				
LMHP12LUU	LMHP12L-A	12		21	0 -0.016	57		0 -0.3		42	0 -0.2	6	6	27	32		4.5	8	4.2	15	650	1,200	4	100	
LMHP13LUU	LMHP13L-A	13		23		61				43		6	6	29	33		4.5	8	4.2	15	810	1,570	4	130	
LMHP16LUU	LMHP16L-A	16		28	70	48		6		6	34	31	22	4.5	8	4.2	15	1,230	2,350	5	187				
LMHP20LUU	LMHP20L-A	20		32	80	54		8		8	38	36	24	5.5	9.5	5.2	20	1,400	2,750	5	260				
LMHP25LUU	LMHP25L-A	25		0 -0.012	40	0 -0.019		112		0 -0.4	62	0 -0.2	8	8	46	40	32	5.5	9.5	5.2	20	1,560	3,140	6	515
LMHP30LUU	LMHP30L-A	30			45			123			74		10	10	51	49	35	6.6	11	6.5	20	2,940	5,490	6	655

- ★1 Dynamic load rating is based on the nominal life of 50km
- ★2 Based on the weight of resin retainer
- ★3 Main unit : mm
- ★4 1N ≒ 0.102kgf
- ★5 Steel retainer available from LMHP06L to LMHP30L only

LMFM FLANGED LONG LINEAR BUSHING

● Drawing

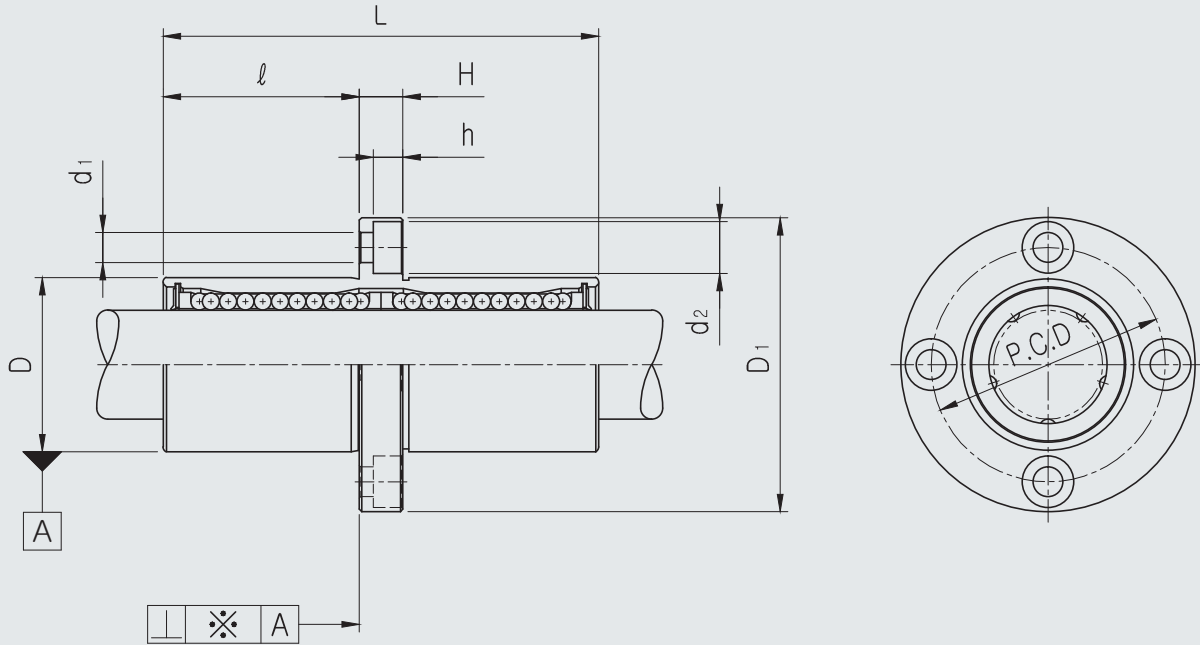

● Part Number Notation

LMFM 20 UU - A N S



- SAMICK Circular Middle Flanged Linear Bushing
- Nominal Shaft Diameter
- Linear Bushing Long Type (for high load)

Blank	No Seal
UU	Both Side Seal
U	One Side Seal

- Retainer (material)

Blank	Resin Retainer(Standard)
A	Steel Retainer(High temperature) ★1

- Outer-sleeves (by corrosion resistance)

Blank	Standard(SUJ2)
N	Electroless nickel plating
R	Raydent treatment

- Ball type (material)

Blank	Standard(High Carbon Chromium Bearing Steel Ball)
S	Stainless steel ball

★1 Steel retainer available from LMFM06 to LMFM30 only

LMFM FLANGED LONG LINEAR BUSHING

PART NUMBER		WORKING BORE DIAMETER		D		L		D ₁		ℓ	H	PCD	d ₁	d ₂	h	SQUAR ENESS ※(μm)	BASIC LOAD RATING(N)		NO. OF BALL ROW	WEIGHT (g) ^{★2}			
Resin	Steel ^{★5}	dr (mm)	Tolerance (mm)	mm	Tolerance (mm)	mm	Tolerance (mm)	mm	Tolerance (mm)								DYNAMIC (C) ^{★1}	STATIC (Co)					
LMFM06UU	LMFM06-A	6	0 -0.010	12	0 -0.013	35	0 -0.3	28	0 -0.2	15	5	20	3.4	6.5	3.2	15	320	520	4	31			
LMFM08UU	LMFM08-A	8		15		45		32		20	5	24	3.4	6.5	3.2	15	430	780	4	53			
LMFM10UU	LMFM10-A	10		19	55	40		24.5		6	29	4.5	8	4.2	15	580	1,100	4	105				
LMFM12UU	LMFM12-A	12		21	0 -0.016	57		0 -0.3		42	0 -0.2	25.5	6	32	4.5	8	4.2	15	650	1,200	4	100	
LMFM13UU	LMFM13-A	13		23		61				43		27.5	6	33	4.5	8	4.2	15	810	1,570	4	130	
LMFM16UU	LMFM16-A	16		28	70	48		32		6	38	4.5	8	4.2	15	1,230	2,350	5	187				
LMFM20UU	LMFM20-A	20		32	80	54		36		8	43	5.5	9.5	5.2	20	1,400	2,750	5	260				
LMFM25UU	LMFM25-A	25		0 -0.012	40	0 -0.019		112		0 -0.4	62	0 -0.3	52	8	51	5.5	9.5	5.2	20	1,560	3,140	6	515
LMFM30UU	LMFM30-A	30			45			123			74		56.5	10	60	6.6	11	6.5	20	2,490	5,490	6	655
LMFM35UU		35		52	135	82		62.5		10	67	6.6	11	6.5	25	2,650	6,470	6	970				
LMFM40UU		40	0 -0.015	60	0 -0.022	154	0 -0.4	96	0 -0.3	70.5	13	78	9	14	8.6	25	3,430	8,040	6	1,560			
LMFM50UU		50		80		192		116		89.5	13	98	9	14	8.6	25	6,080	15,900	6	3,500			
LMFM60UU		60	0 -0.020	90	0 -0.025	211		134		96.5	18	112	11	17.5	10.8	30	7,650	20,000	6	4,500			

- ★1 Dynamic load rating is based on the nominal life of 50km
- ★2 Based on the weight of resin retainer
- ★3 Main unit : mm
- ★4 1N ≒ 0.102kgf
- ★5 Steel retainer available from LMFM06 to LMFM30 only

LMKM FLANGED LONG LINEAR BUSHING

● Drawing

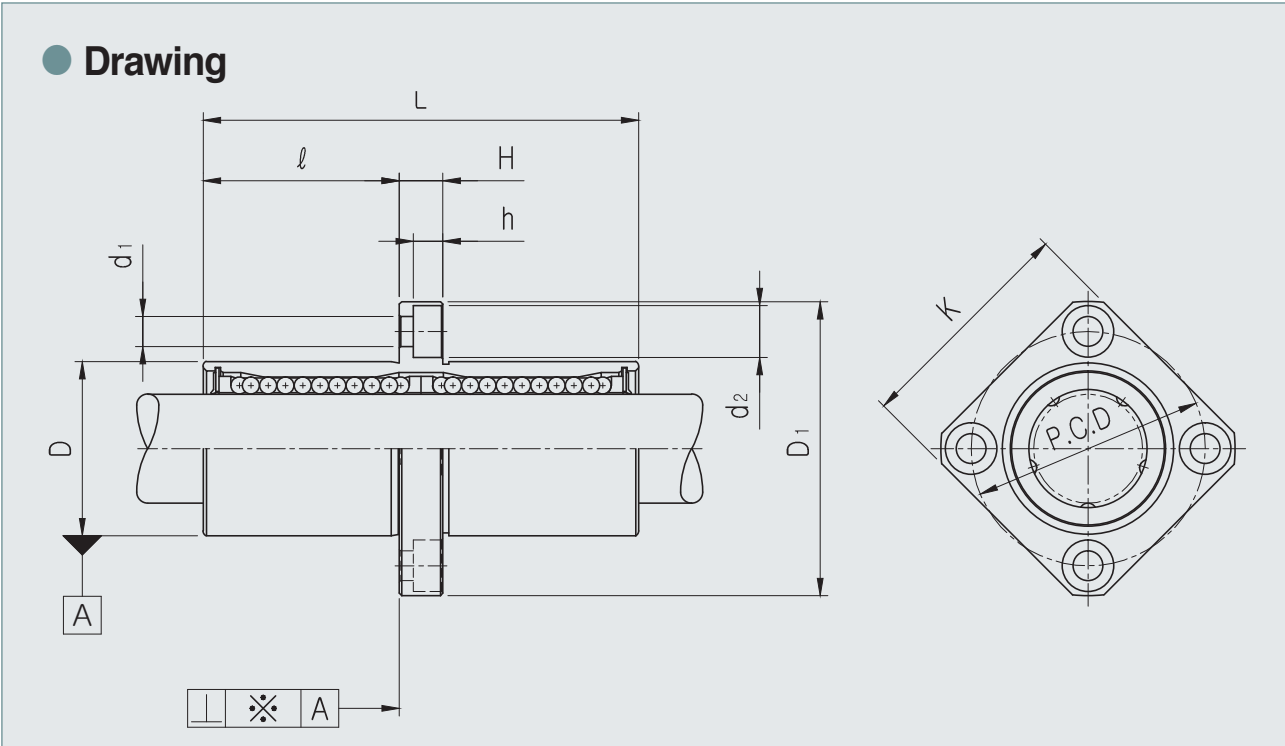

● Part Number Notation

LMKM 20 UU - A N S

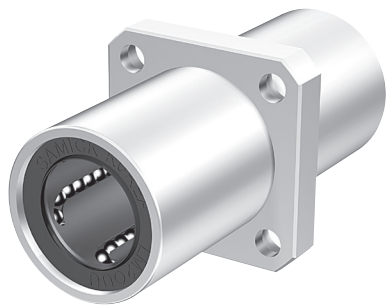

- SAMICK Square Middle Flanged Linear Bushing
- Nominal Shaft Diameter
- Linear Bushing Long Type (for high load)

Blank	No Seal
UU	Both Side Seal
U	One Side Seal

- Retainer (material)

Blank	Resin Retainer(Standard)
A	Steel Retainer(High temperature) ^{★1}

- Outer-sleeves (by corrosion resistance)

Blank	Standard(SUJ2)
N	Electroless nickel plating
R	Raydent treatment

- Ball type (material)

Blank	Standard(High Carbon Chromium Bearing Steel Ball)
S	Stainless steel ball

★1 Steel retainer available from LMKM06 to LMKM30 only

LMKM FLANGED LONG LINEAR BUSHING

PART NUMBER		WORKING BORE DIAMETER		D		L		D ₁		ℓ	H	PCD	K	d ₁	d ₂	h	SQUAR ENESS ※(μm)	BASIC LOAD RATING(N)		NO. OF BALL ROW	WEIGHT (gf) ^{★2}			
Resin	Steel ^{★5}	dr. (mm)	Tolerance (mm)	mm	Tolerance (mm)	mm	Tolerance (mm)	mm	Tolerance (mm)									DYNAMIC (C) ^{★1}	STATIC (Co)					
LMKM06UU	LMKM06-A	6	0 -0.010	12	0 -0.013	35	0 -0.3	28	0 -0.2	15	5	20	22	3.4	6.5	3.2	15	320	520	4	31			
LMKM08UU	LMKM08-A	8		15		45		32		20	5	24	25	3.4	6.5	3.2	15	430	780	4	53			
LMKM10UU	LMKM10-A	10		19	55	40		24.5		6	29	30	4.5	8	4.2	15	580	1,100	4	105				
LMKM12UU	LMKM12-A	12		21	0 -0.016	57		0 -0.2		42	0 -0.2	25.5	6	32	32	4.5	8	4.2	15	650	1,200	4	100	
LMKM13UU	LMKM13-A	13		23		61				43		27.5	6	33	34	4.5	8	4.2	15	810	1,570	4	130	
LMKM16UU	LMKM16-A	16		28		70				48		32	6	38	37	4.5	8	4.2	15	1,230	2,350	5	187	
LMKM20UU	LMKM20-A	20		32	80	54		36		8	43	42	5.5	9.5	5.2	20	1,400	2,750	5	260				
LMKM25UU	LMKM25-A	25		0 -0.012	40	0 -0.019		112		0 -0.4	62	0 -0.3	52	8	51	50	5.5	9.5	5.2	20	1,560	3,140	6	515
LMKM30UU	LMKM30-A	30			45			123			74		56.5	10	60	58	6.6	11	6.5	20	2,490	5,490	6	655
LMKM35UU		35		52	135	82		62.5		10	67	64	6.6	11	6.5	25	2,650	6,470	6	970				
LMKM40UU		40	0 -0.015	60	0 -0.022	154	0 -0.4	96	0 -0.3	70.5	13	78	75	9	14	8.6	25	3,430	8,040	6	1,560			
LMKM50UU		50		80		192		116		89.5	13	98	92	9	14	8.6	25	6,080	15,900	6	3,500			
LMKM60UU		60	0 -0.020	90	0 -0.025	211		134		96.5	18	112	106	11	17.5	10.8	30	7,650	20,000	6	4,500			

- ★1 Dynamic load rating is based on the nominal life of 50km
- ★2 Based on the weight of resin retainer
- ★3 Main unit : mm
- ★4 1N ≒ 0.102kgf
- ★5 Steel retainer available from LMKM06 to LMKM30 only

LMHM FLANGED LONG LINEAR BUSHING

● Drawing

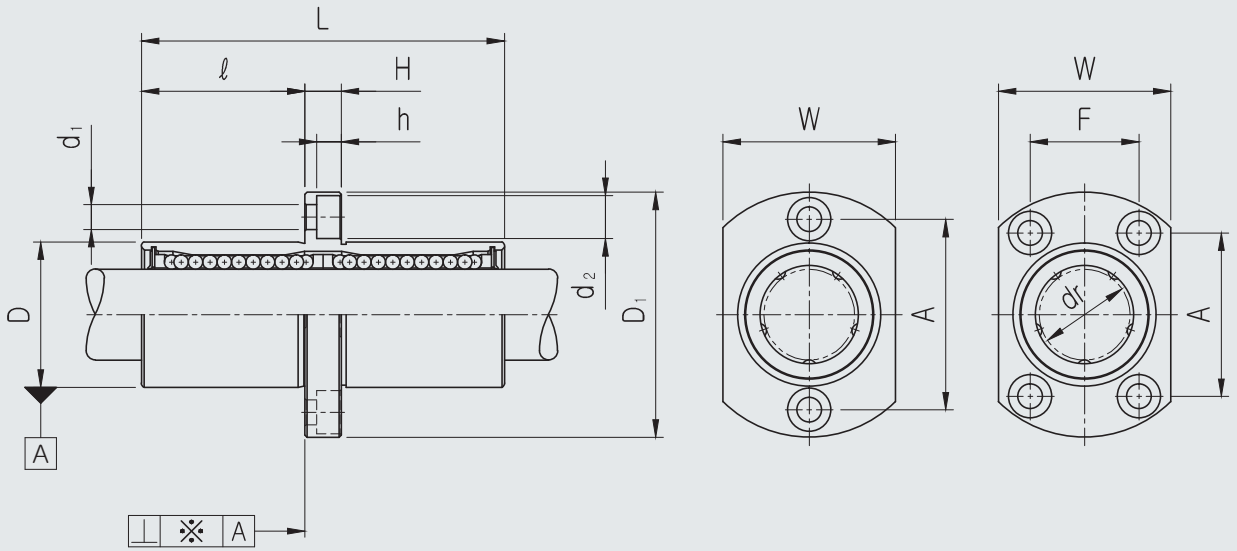

● Part Number Notation

LMHM 20 UU - A N S

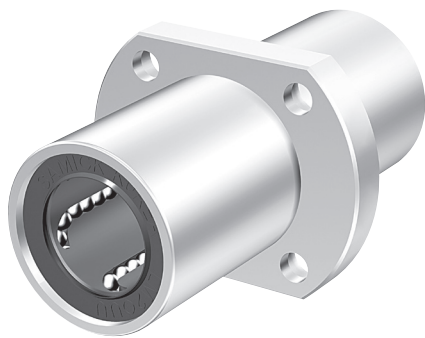

- SAMICK Oval Middle Flanged Linear Bushing
- Nominal Shaft Diameter
- Linear Bushing Long Type (for high load)

Blank	No Seal
UU	Both Side Seal
U	One Side Seal

- Retainer (material)

Blank	Resin Retainer(Standard)
A	Steel Retainer(High temperature) ^{★1}

- Outer-sleeves (by corrosion resistance)

Blank	Standard(SUJ2)
N	Electroless nickel plating
R	Raydent treatment

- Ball type (material)

Blank	Standard(High Carbon Chromium Bearing Steel Ball)
S	Stainless steel ball

★1 Steel retainer available from LMHM06 to LMHM30 only

LMHM FLANGED LONG LINEAR BUSHING

PART NUMBER		WORKING BORE DIAMETER		D		L		D ₁		ℓ	H	W	A	F	d ₁	d ₂	h	SQUAR ENESS ※(μm)	BASIC LOAD RATING(N)		NO. OF BALL ROW	WEIGHT (gf) ^{★2}			
Resin	Steel ^{★5}	dr. (mm)	Tolerance (mm)	mm	Tolerance (mm)	mm	Tolerance (mm)	mm	Tolerance (mm)									DYNAMIC (C) ^{★1}	STATIC (Co)						
LMHM06UU	LMHM06-A	6	0 -0.010	12	0 -0.013	35	0 -0.3	28	0 -0.2	15	5	18	20		3.4	6.5	3.2	15	320	520	4	31			
LMHM08UU	LMHM08-A	8		15		45		32		20	5	21	24		3.4	6.5	3.2	15	430	780	4	53			
LMHM10UU	LMHM10-A	10		19	55	40		24.5		6	25	29		4.5	8	4.2	15	580	1,100	4	105				
LMHM12UU	LMHM12-A	12		21	0 -0.016	57		0 -0.3		42	0 -0.2	25.5	6	27	32		4.5	8	4.2	15	650	1,200	4	100	
LMHM13UU	LMHM13-A	13		23		61				43		27.5	6	29	33		4.5	8	4.2	15	810	1,570	4	130	
LMHM16UU	LMHM16-A	16		28		70				48		32	6	34	31	22	4.5	8	4.2	15	1,230	2,350	5	187	
LMHM20UU	LMHM20-A	20		32	80	54		36		8	38	36	24	5.5	9.5	5.2	20	1,400	2,750	5	260				
LMHM25UU	LMHM25-A	25		0 -0.012	40	0 -0.019		112		0 -0.4	62	0 -0.2	52	8	46	40	32	5.5	9.5	5.2	20	1,560	3,140	6	515
LMHM30UU	LMHM30-A	30			45			123			74		56.5	10	51	49	35	6.6	11	6.5	20	2,490	5,490	6	655

- ★1 Dynamic load rating is based on the nominal life of 50km
- ★2 Based on the weight of resin retainer
- ★3 Main unit : mm
- ★4 1N ≒ 0.102kgf
- ★5 Steel retainer available from LMHM06 to LMHM30 only

117

EUROPEAN STANDARD LINEARBUSHING(LME)

LME CLOSED LINEAR BUSHING

● Drawing

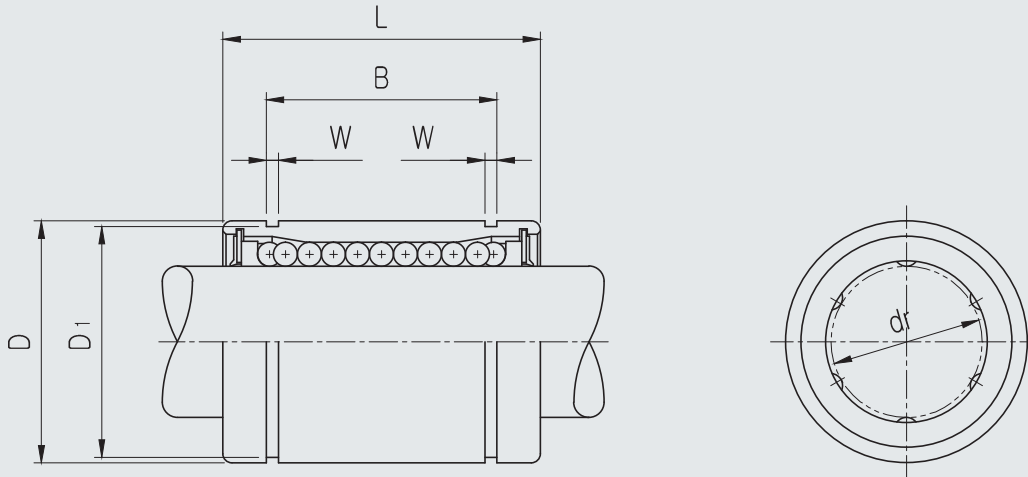

● Part Number Notation

LME 20 UU - A N S



- European Standard Samick Linear Bushing
- Nominal Shaft Diameter
- Seal

Blank	No Seal
UU	Both Side Seal
U	One Side Seal

- Retainer (material)

Blank	Resin Retainer(Standard)
A	Steel Retainer(High temperature) ★ ¹

- Outer-sleeves (by corrosion resistance)

Blank	Standard(SUJ2)
N	Electroless nickel plating
R	Raydent treatment

- Ball type (material)

Blank	Standard(High Carbon Chromium Bearing Steel Ball)
S	Stainless steel ball

★¹ Steel retainer available from LME08 to LME30 only

LME CLOSED LINEAR BUSHING

PART NUMBER		WORKING BORE DIAMETER		D		L		B		W	D ₁	BASIC LOAD RATING(N)		NO. OF BALL ROW	WEIGHT (gf) ^{*2}
Resin	Steel ^{*5}	dr. (mm)	Tolerance (mm)	mm	Tolerance (mm)	mm	Tolerance (mm)	mm	Tolerance (mm)			DYNAMIC (C) ^{*1}	STATIC (Co)		
LME05UU		5	+0.008 0	12	0 -0.008	22	0 -0.2	14.5	0 -0.2	1.1	11.5	200	260	4	12
LME08UU	LME08-A	8		16		25		16.5		1.1	15.2	260	400	4	20
LME12UU	LME12-A	12		22	0 -0.009	32		22.9		1.3	21	410	590	4	41
LME16UU	LME16-A	16	26	36		24.9	1.3	24.9	770	1,170	5	57			
LME20UU	LME20-A	20	+0.009 -0.001	32	0 -0.011	45	0 -0.3	31.5	0 -0.3	1.6	30.3	860	1,370	5	91
LME25UU	LME25-A	25		40		58		44.1		1.85	37.5	980	1,560	6	215
LME30UU	LME30-A	30	47	68	52.1	1.85		44.5		1,560	2,740	6	325		
LME40UU		40	+0.013 -0.002	62	0 -0.013	80	0 -0.4	60.6	0 -0.4	2.15	59	2,150	4,010	6	705
LME50UU		50		75		100		77.6		2.65	72	3,820	7,930	6	1,130
LME60UU		60		90	125	101.7		3.15		86.5	4,700	9,990	6	2,220	

- ★1 Dynamic load rating is based on the nominal life of 50km
- ★2 Based on the weight of resin retainer
- ★3 Main unit : mm
- ★4 1N ≒ 0.102kgf
- ★5 Steel retainer available from LME08 to LME30 only

LME_L LONG LINEAR BUSHING

● Drawing

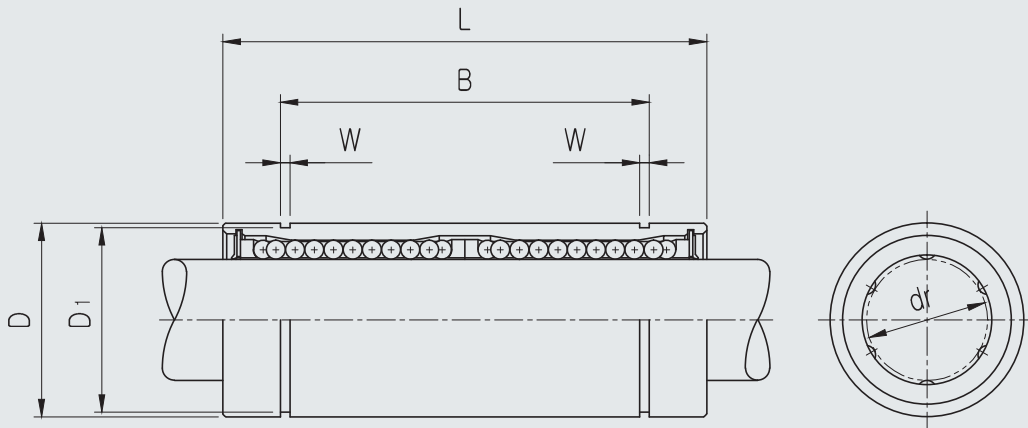

● Part Number Notation

LME 20 L UU - A N S



- European Standard Samick Linear Bushing
- Nominal Shaft Diameter
- Linear Bushing Long Type (for high load)
- Seal

Blank	No Seal
UU	Both Side Seal
U	One Side Seal

- Retainer (material)

Blank	Resin Retainer(Standard)
A	Steel Retainer(High temperature) ★1

- Outer-sleeves (by corrosion resistance)

Blank	Standard(SUJ2)
N	Electroless nickel plating
R	Raydent treatment

- Ball type (material)

Blank	Standard(High Carbon Chromium Bearing Steel Ball)
S	Stainless steel ball

★1 Steel retainer available from LME08L to LME30L only

LME_L LONG LINEAR BUSHING

PART NUMBER		WORKING BORE DIAMETER		D		L		B		W	D ₁	BASIC LOAD RATING(N)		NO. OF BALL ROW	WEIGHT (gf) ^{*2}
Resin	Steel ^{*5}	dr. (mm)	Tolerance (mm)	mm	Tolerance (mm)	mm	Tolerance (mm)	mm	Tolerance (mm)			DYNAMIC (C) ^{*1}	STATIC (Co)		
LME08LUU	LME08L-A	8	+0.009 -0.001	16	0 -0.009	45	0 -0.3	33	0 -0.3	1.1	15.2	430	780	4	31
LME12LUU	LME12L-A	12		22	0 -0.011	57		45.8		1.3	21	650	1,200	4	80
LME16LUU	LME16L-A	16	+0.011 -0.001	26	0 -0.013	70	0 -0.4	49.8	0 -0.4	1.3	24.9	1,230	2,350	5	145
LME20LUU	LME20L-A	20		32		80		61		1.6	30.3	1,400	2,750	5	180
LME25LUU	LME25L-A	25	+0.013 -0.002	40	0 -0.015	112	0 -0.4	82	0 -0.4	1.85	38	1,560	3,140	6	440
LME30LUU	LME30L-A	30		47		123		104.2		1.85	44.5	2,490	5,490	6	580
LME40LUU		40	+0.016 -0.004	62	0 -0.020	154	0 -0.4	121.2	0 -0.4	2.15	59	3,430	8,040	6	1,170
LME50LUU		50		75		192		155.2		2.65	72	6,080	15,900	6	3,100
LME60LUU		60		90		211		170		3.15	86.5	7,650	20,000	6	3,500

- ★1 Dynamic load rating is based on the nominal life of 50km
- ★2 Based on the weight of resin retainer
- ★3 Main unit : mm
- ★4 1N ≒ 0.102kgf
- ★5 Steel retainer available from LME08L to LME30L only

LME_AJ ADJUSTABLE LINEAR BUSHING

● Drawing

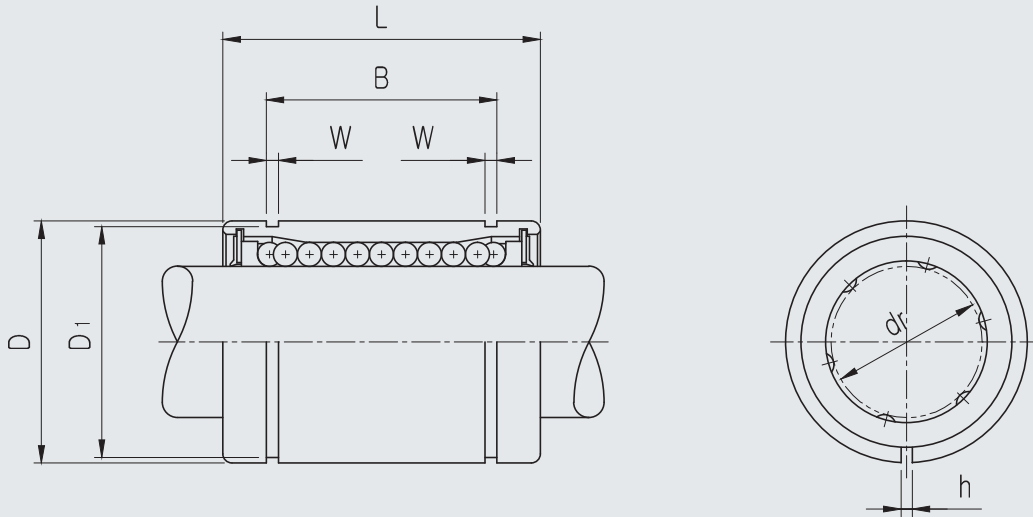

● Part Number Notation

LME 20 UU AJ - A N S



- European Standard Samick Linear Bushing
- Nominal Shaft Diameter
- Seal

Blank	No Seal
UU	Both Side Seal
U	One Side Seal

- Linear Bushing Adjustable type
- Retainer (material)

Blank	Resin Retainer(Standard)
A	Steel Retainer(High temperature) ★1

- Outer-sleeves (by corrosion resistance)

Blank	Standard(SUJ2)
N	Electroless nickel plating
R	Raydent treatment

- Ball type (material)

Blank	Standard(High Carbon Chromium Bearing Steel Ball)
S	Stainless steel ball

★1 Steel retainer available from LME08AJ to LME30AJ only

LME_AJ ADJUSTABLE LINEAR BUSHING

PART NUMBER		WORKING BORE DIAMETER		D* ⁴		L		B		W	D ₁	h	BASIC LOAD RATING(N)		NO. OF BALL ROW	WEIGHT (g) ^{*2}
Resin	Steel* ⁶	dr. (mm)	Tolerance (mm)	mm	Tolerance (mm)	mm	Tolerance (mm)	mm	Tolerance (mm)				DYNAMIC (C) ^{*1}	STATIC (Co)		
LME05UUAJ		5	+0.008 0	12	0 -0.008	22	0 -0.2	14.5	0 -0.2	1.1	11.5	1	200	260	4	12
LME08UUAJ	LME08AJ-A	8		16	25	16.5		1.1		15.2	1	260	400	4	20	
LME12UUAJ	LME12AJ-A	12	+0.009 -0.001	22	0 -0.009	32	0 -0.3	22.9	0 -0.3	1.3	21	1.5	410	590	4	41
LME16UUAJ	LME16AJ-A	16		26	36	24.9		1.3		24.9	1.5	770	1,170	5	57	
LME20UUAJ	LME20AJ-A	20	+0.011 -0.001	32	0 -0.011	45	0 -0.3	31.5	0 -0.3	1.6	30.3	2	860	1,370	5	91
LME25UUAJ	LME25AJ-A	25		40		58		44.1		1.85	37.5	2	980	1,560	6	215
LME30UUAJ	LME30AJ-A	30	+0.013 -0.002	47	0 -0.013	68	0 -0.4	52.1	0 -0.4	1.85	44.5	2	1,560	2,740	6	325
LME40UUAJ		40		62		80		60.6		2.15	59	3	2,150	4,010	6	705
LME50UUAJ		50	+0.013 -0.002	75	0 -0.015	100	0 -0.4	77.6	0 -0.4	2.65	72	3	3,820	7,930	6	1,130
LME60UUAJ		60		90		125		101.7		3.15	86.5	3	4,700	9,990	6	2,220

- ★1 Dynamic load rating is based on the nominal life of 50km
- ★2 Based on the weight of resin retainer
- ★3 Main unit : mm
- ★4 Outer diameter is the obtained value before the slotting process.
- ★5 1N ≒ 0.102kgf
- ★6 Steel retainer available from LME08AJ to LME30AJ only

LME_OP OPEN LINEAR BUSHING

● Drawing

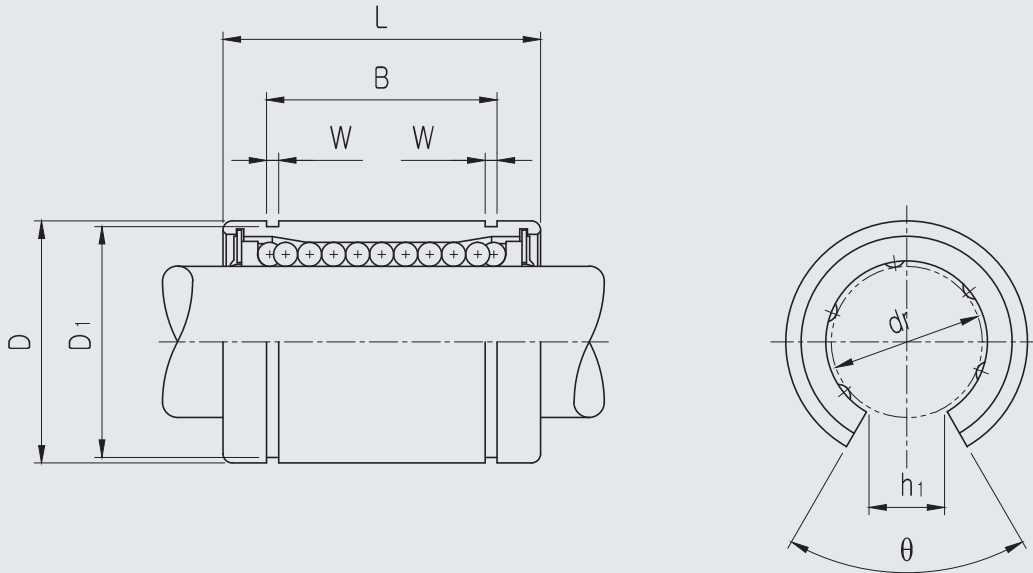

● Part Number Notation

LME 20 UU OP - N S

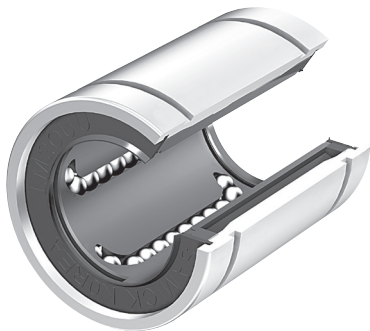

- European Standard Samick Linear Bushing
- Nominal Shaft Diameter
- Seal

UU	Both Side Seal ^{★1}
----	------------------------------

- Linear Bushing Open type
- Outer-sleeves (by corrosion resistance)

Blank	Standard(SUJ2)
N	Electroless nickel plating
R	Raydent treatment

- Ball type (material)

Blank	Standard(High Carbon Chromium Bearing Steel Ball)
S	Stainless steel ball

* ★1 UU type only available.
 No seal type & One side seal type not available.
 ★ Resin retainer only available

LME_OP OPEN LINEAR BUSHING

PART NUMBER	WORKING BORE DIAMETER		D*4		L		B		W	D ₁	h	θ	BASIC LOAD RATING(N)		NO. OF BALL ROW	WEIGHT (gf)*2
	Resin	dr. (mm)	Tolerance (mm)	mm	Tolerance (mm)	mm	Tolerance (mm)	mm					Tolerance (mm)	DYNAMIC (C)*1		
LME12UUOP	12	+0.008 0	22	0 -0.009	32	0 -0.2	22.9	0 -0.2	1.3	21	7.5	78°	410	590	3	41
LME16UUOP	16	+0.009 -0.001	26	0 -0.011	36	0 -0.3	24.9	0 -0.3	1.3	24.9	10	78°	770	1,170	4	57
LME20UUOP	20	+0.011 -0.0011	32	0 -0.013	45	0 -0.4	31.5	0 -0.4	1.6	30.3	10	60°	860	1,370	4	91
LME25UUOP	25	+0.013 -0.002	40	0 -0.015	58	0 -0.4	44.1	0 -0.4	1.85	37.5	12.5	60°	980	1,560	5	215
LME30UUOP	30	+0.013 -0.002	47	0 -0.015	68	0 -0.4	52.1	0 -0.4	1.85	44.5	12.5	50°	1,560	2,740	5	325
LME40UUOP	40	+0.013 -0.002	62	0 -0.015	80	0 -0.4	60.6	0 -0.4	2.15	59	16.8	50°	2,150	4,010	5	705
LME50UUOP	50	+0.013 -0.002	75	0 -0.015	100	0 -0.4	77.6	0 -0.4	2.65	72	21	50°	3,820	7,930	5	1,130
LME60UUOP	60	+0.013 -0.002	90	0 -0.015	125	0 -0.4	101.7	0 -0.4	3.15	86.5	27.2	54°	4,700	9,990	5	2,220

- ★1 Dynamic load rating is based on the nominal life of 50km
- ★2 Based on the weight of resin retainer
- ★3 Main unit : mm
- ★4 Outer diameter is the obtained value before the slotting process.
- ★5 1N ≙ 0.102kgf

LMEF FLANGED LINEAR BUSHING

● Drawing

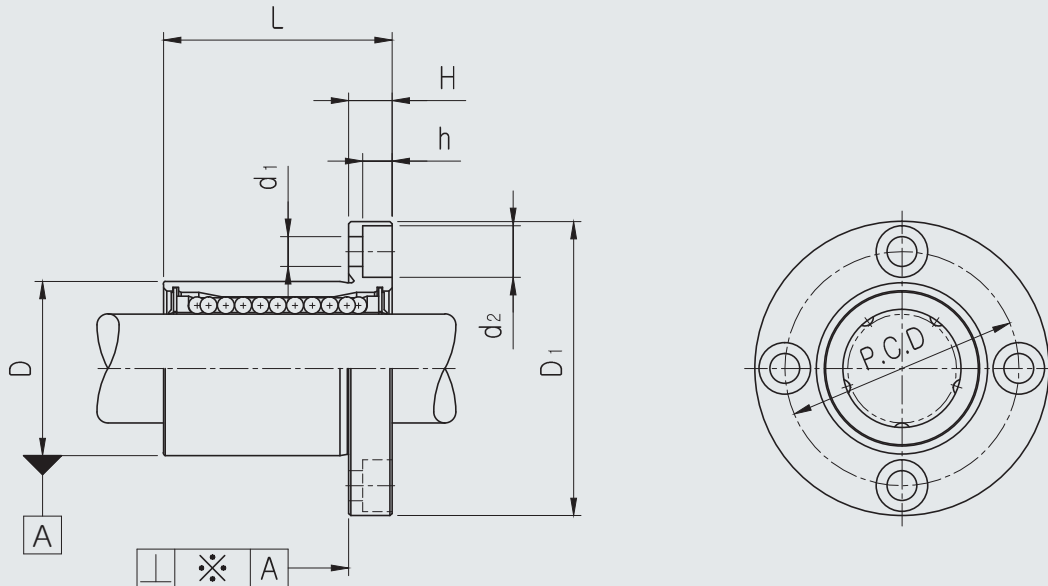

● Part Number Notation

LMEF 20 UU - A N S



- European Standard Samick Circular Flanged Linear Bushing
- Nominal Shaft Diameter
- Seal

Blank	No Seal
UU	Both Side Seal
U	One Side Seal

- Retainer (material)

Blank	Resin Retainer(Standard)
A	Steel Retainer(High temperature) ^{★1}

- Outer-sleeves (by corrosion resistance)

Blank	Standard(SUJ2)
N	Electroless nickel plating
R	Raydent treatment

- Ball type (material)

Blank	Standard(High Carbon Chromium Bearing Steel Ball)
S	Stainless steel ball

★1 Resin retainer available from LMEF08 to LMEF30 only

LMEF FLANGED LINEAR BUSHING

PART NUMBER		WORKING BORE DIAMETER		D		L		B		H	PCD	d ₁	d ₂	h	SQUARENESSE ※(μm)	BASIC LOAD RATING(N)		NO. OF BALL ROW	WEIGHT (gf) ^{*2}
Resin	Steel ^{*5}	dr. (mm)	Tolerance (mm)	mm	Tolerance (mm)	mm	Tolerance (mm)	mm	Tolerance (mm)							DYNAMIC (C) ^{*1}	STATIC (Co)		
LMEF08UU	LMEF08-A	8	+0.008 0	16	0 -0.008	25	±0.2	32	0	5	24	3.4	6.5	3.2	12	260	400	4	44
LMEF12UU	LMEF12-A	12	+0.009 -0.001	22	0 -0.009	32		42		6	32	4.5	8	4.2	12	410	590	4	86
LMEF16UU	LMEF16-A	16		+0.011 -0.001	26	0 -0.011	36	±0.3	46	0	6	36	4.5	8	4.2	12	770	1,170	5
LMEF20UU	LMEF20-A	20	32		45		54		8		43	5.5	9.5	5.2	15	860	1,370	5	184
LMEF25UU	LMEF25-A	25	+0.013 -0.002	40	0 -0.013	58	±0.4	62	0	8	51	5.5	9.5	5.2	15	980	1,560	6	335
LMEF30UU	LMEF30-A	30		47		68		76		10	62	6.6	11	6.5	15	1,560	2,740	6	545
LMEF40UU		40	+0.013 -0.002	62	0 -0.013	80	±0.4	98	0	13	80	9	14	8.6	20	2,150	4,010	6	1,185
LMEF50UU		50		75		100		112		13	94	9	14	8.6	20	3,820	7,930	6	1,730
LMEF60UU		60		90	0 -0.015	125	±0.4	134		18	112	11	17.5	10.8	25	4,700	9,990	6	3,180

- ★1 Dynamic load rating is based on the nominal life of 50km
- ★2 Based on the weight of resin retainer
- ★3 Main unit : mm
- ★4 1N ≒ 0.102kgf
- ★5 Resin retainer available from LMEF08 to LMEF30 only

LMEF_L FLANGED LONG LINEAR BUSHING

● Drawing

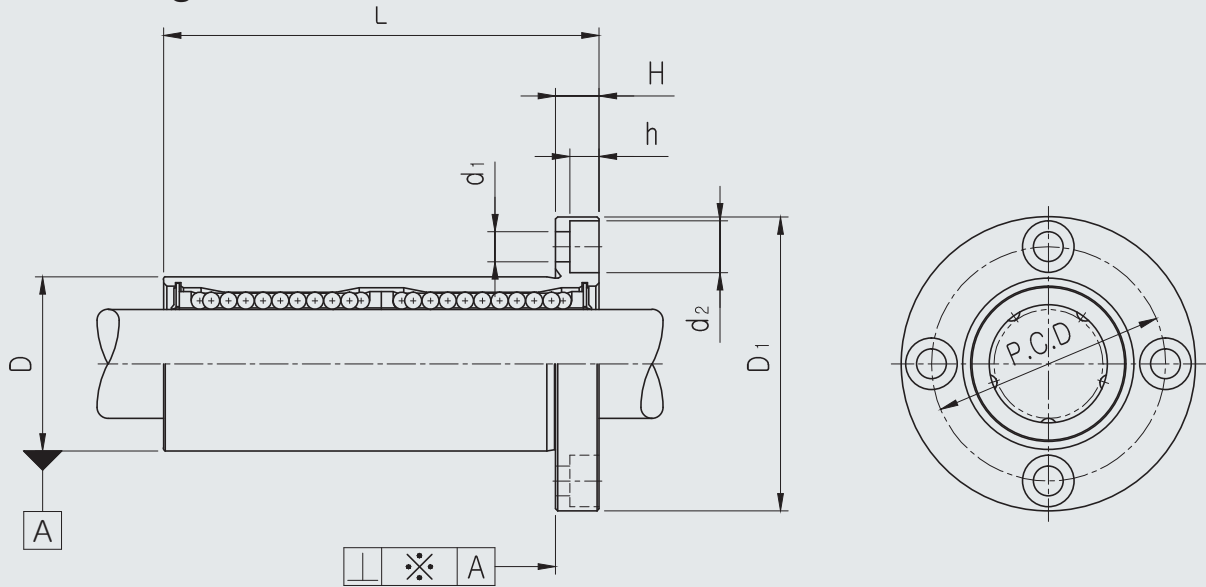

● Part Number Notation

LMEF 20 L UU - A N S



- European Standard Samick Circular Flanged Linear Bushing
- Nominal Shaft Diameter
- Linear Bushing Long Type (for high load)
- Seal

Blank	No Seal
UU	Both Side Seal
U	One Side Seal

- Retainer (material)

Blank	Resin Retainer(Standard)
A	Steel Retainer(High temperature) ★1

- Outer-sleeves (by corrosion resistance)

Blank	Standard(SUJ2)
N	Electroless nickel plating
R	Raydent treatment

- Ball type (material)

Blank	Standard(High Carbon Chromium Bearing Steel Ball)
S	Stainless steel ball

★1 Steel retainer available from LMEF08L to LMEF30L only

LMEF_L FLANGED LONG LINEAR BUSHING

PART NUMBER		WORKING BORE DIAMETER		D		L		B		H	PCD	d ₁	d ₂	h	SQUAREDNESS ※(μm)	BASIC LOAD RATING(N)		NO. OF BALL ROW	WEIGHT (gf) ^{★2}
Resin	Steel ^{★5}	dr. (mm)	Tolerance (mm)	mm	Tolerance (mm)	mm	Tolerance (mm)	mm	Tolerance (mm)							DYNAMIC (C) ^{★1}	STATIC (Co)		
LMEF08LUU	LMEF08L-A	8	+0.009 -0.001	16	0 -0.009	45	±0.3	32	0 -0.2	5	24	3.4	6.5	3.2	15	430	780	4	53
LMEF12LUU	LMEF12L-A	12		22	0 -0.011	57		42		6	32	4.5	8	4.2	15	650	1,200	4	100
LMEF16LUU	LMEF16L-A	16	+0.011 -0.001	26	0 -0.013	70	±0.4	46	0 -0.3	6	36	4.5	8	4.2	15	1,230	2,350	5	187
LMEF20LUU	LMEF20L-A	20		32		80		54		8	43	5.5	9.5	5.2	17	1,400	2,750	5	260
LMEF25LUU	LMEF25L-A	25	+0.013 -0.002	40	0 -0.015	112	±0.4	62	0 -0.3	8	51	5.5	9.5	5.2	17	1,560	3,140	6	515
LMEF30LUU	LMEF30L-A	30		47		123		76		10	62	6.6	11	6.5	17	2,490	5,490	6	655
LMEF40LUU		40	+0.016 -0.004	62	0 -0.020	154	±0.4	98	0 -0.3	13	80	9	14	8.6	20	3,430	8,040	6	1,560
LMEF50LUU		50		75		192		112		13	94	9	14	8.6	20	6,080	15,900	6	3,500
LMEF60LUU		60		90		211		134		18	112	11	17.5	10.8	30	7,650	20,000	6	4,500

- ★1 Dynamic load rating is based on the nominal life of 50km
- ★2 Based on the weight of resin retainer
- ★3 Main unit : mm
- ★4 1N ≒ 0.102kgf
- ★5 Steel retainer available from LMEF08L to LMEF30L only

LMEK FLANGED LINEAR BUSHING

● Drawing

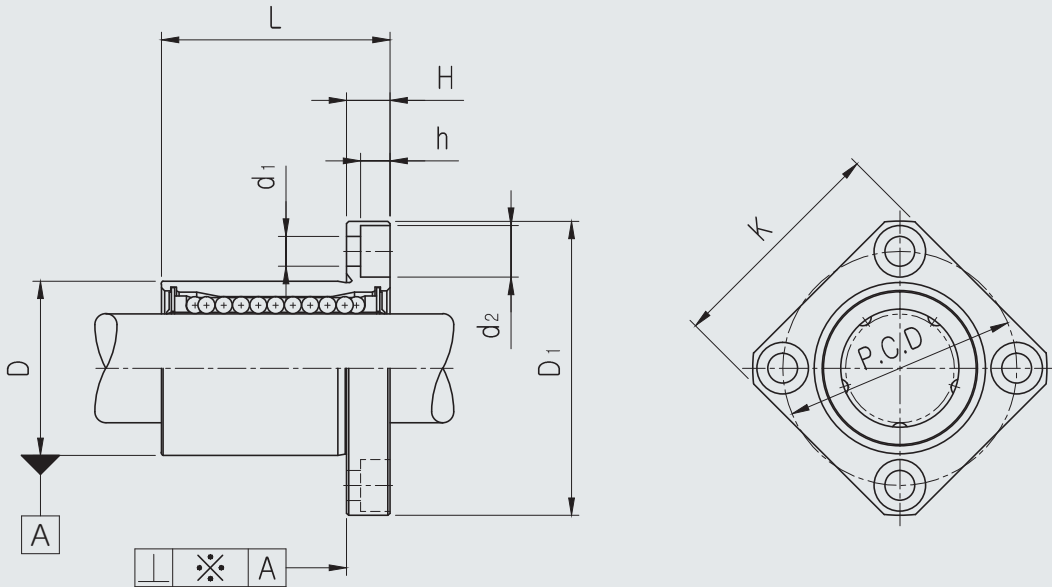

● Part Number Notation

LMEK 20 UU - A N S

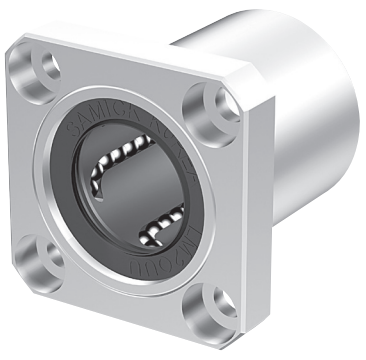

- European Standard Samick Square Flanged Linear Bushing
- Nominal Shaft Diameter
- Seal

Blank	No Seal
UU	Both Side Seal
U	One Side Seal

- Retainer (material)

Blank	Resin Retainer(Standard)
A	Steel Retainer(High temperature) ^{★1}

- Outer-sleeves (by corrosion resistance)

Blank	Standard(SUJ2)
N	Electroless nickel plating
R	Raydent treatment

- Ball type (material)

Blank	Standard(High Carbon Chromium Bearing Steel Ball)
S	Stainless steel ball

★1 Steel retainer available from LMEK08 to LMEK30 only

LMEK FLANGED LINEAR BUSHING

PART NUMBER		WORKING BORE DIAMETER		D		L		D ₁		H	PCD	K	d ₁	d ₂	h	SQUAR ENESS ※(μm)	BASIC LOAD RATING(N)		NO. OF BALL ROW	WEIGHT (gf) ^{★2}
Resin	Steel ^{★5}	dr. (mm)	Tolerance (mm)	mm	Tolerance (mm)	mm	Tolerance (mm)	mm	Tolerance (mm)								DYNAMIC (C) ^{★1}	STATIC (Co)		
LMEK08UU	LMEK08-A	8	+0.008 0	16	0 -0.008	25		32		5	24	25	3.4	6.5	3.2	12	260	400	4	44
LMEK12UU	LMEK12-A	12		22	0 -0.009	32	±0.2	42		6	32	32	4.5	8	4.2	12	410	590	4	86
LMEK16UU	LMEK16-A	16	+0.009 -0.001	26		36		46	0	6	36	35	4.5	8	4.2	12	770	1,170	5	120
LMEK20UU	LMEK20-A	20		32		45		54	-0.2	8	43	42	5.5	9.5	5.2	15	860	1,370	5	184
LMEK25UU	LMEK25-A	25	+0.011 -0.001	40	0 -0.011	58		62		8	51	50	5.5	9.5	5.2	15	980	1,560	6	335
LMEK30UU	LMEK30-A	30		47		68	±0.3	76		10	62	60	6.6	11	6.5	15	1,560	2,740	6	545
LMEK40UU		40		62	0 -0.013	80		98		13	80	75	9	14	8.6	20	2,150	4,010	6	1,185
LMEK50UU		50	+0.013 -0.002	75		100		112	0 -0.3	13	94	88	9	14	8.6	20	3,820	7,930	6	1,730
LMEK60UU		60		90	0 -0.015	125	±0.4	134		18	112	106	11	17.5	10.8	25	4,700	9,990	6	3,180

- ★1 Dynamic load rating is based on the nominal life of 50km
- ★2 Based on the weight of resin retainer
- ★3 Main unit : mm
- ★4 1N ≒ 0.102kgf
- ★5 Steel retainer available from LMEK08 to LMEK30 only

LMEK_L FLANGED LONG LINEAR BUSHING

● Drawing

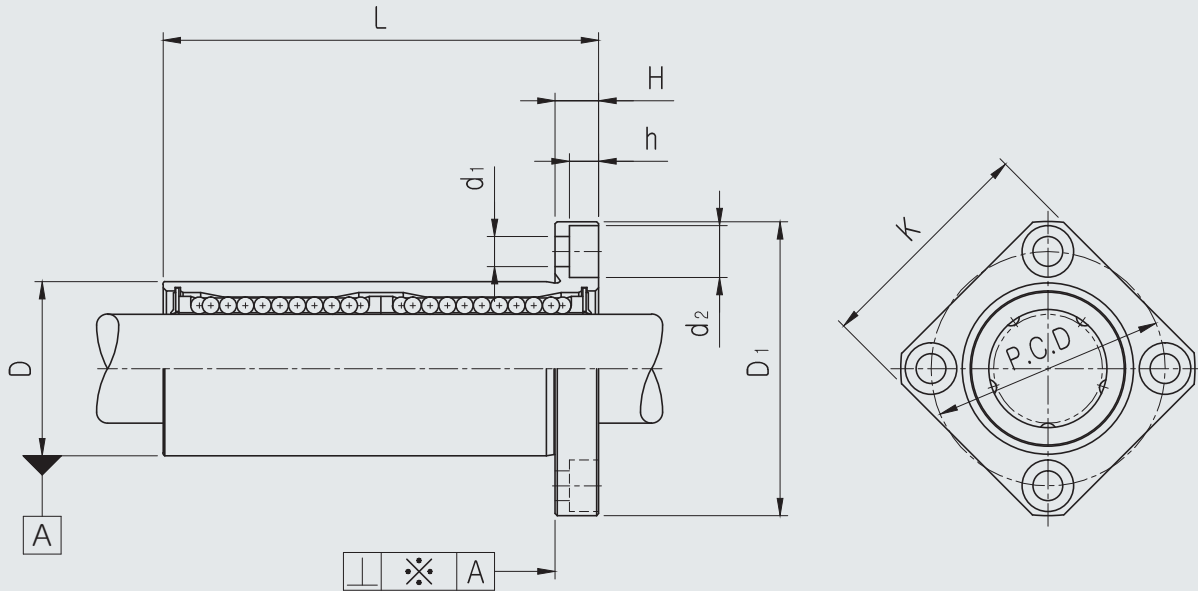

● Part Number Notation

LMEK 20 L UU - A N S

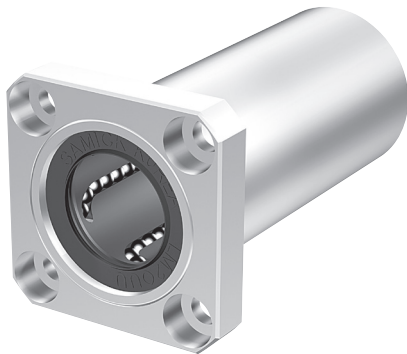

- European Standard Samick Square Flanged Linear Bushing
- Nominal Shaft Diameter
- Linear Bushing Long Type (for high load)
- Seal

Blank	No Seal
UU	Both Side Seal
U	One Side Seal

- Retainer (material)

Blank	Resin Retainer(Standard)
A	Steel Retainer(High temperature) ★1

- Outer-sleeves (by corrosion resistance)

Blank	Standard(SUJ2)
N	Electroless nickel plating
R	Raydent treatment

- Ball type (material)

Blank	Standard(High Carbon Chromium Bearing Steel Ball)
S	Stainless steel ball

★1 Steel retainer available from LMEK08L to LMEK30L only

LMEK_L FLANGED LONG LINEAR BUSHING

PART NUMBER		WORKING BORE DIAMETER		D		L		D ₁		H	PCD	K	d ₁	d ₂	h	SQUAR ENESS ※(μm)	BASIC LOAD RATING(N)		NO. OF BALL ROW	WEIGHT (gf) ^{★2}	
Resin	Steel ^{★5}	dr. (mm)	Tolerance (mm)	mm	Tolerance (mm)	mm	Tolerance (mm)	mm	Tolerance (mm)								DYNAMIC (C) ^{★1}	STATIC (Co)			
LMEK08LUU	LMEK08L-A	8	+0.009 -0.001	16	0 -0.009	45	±0.3	32	0 -0.2	5	24	25	3.4	6.5	3.2	15	430	780	4	53	
LMEK12LUU	LMEK12L-A	12		22	0 -0.011	57		42		6	32	32	4.5	8	4.2	15	650	1,200	4	100	
LMEK16LUU	LMEK16L-A	16	+0.011 -0.001	26	0 -0.013	70		46		6	36	35	4.5	8	4.2	15	1,230	2,350	5	187	
LMEK20LUU	LMEK20L-A	20		32		80		54		8	43	42	5.5	9.5	5.2	17	1,400	2,750	5	260	
LMEK25LUU	LMEK25L-A	25	+0.013 -0.002	40	0 -0.015	112	±0.4	62		0 -0.3	8	51	50	5.5	9.5	5.2	17	1,560	3,140	6	515
LMEK30LUU	LMEK30L-A	30		47		123		76			10	62	60	6.6	11	6.5	17	2,490	5,490	6	655
LMEK40LUU		40	+0.016 -0.004	62	0 -0.020	154		98			13	80	75	9	14	8.6	20	3,430	8,40	6	1,560
LMEK50LUU		50		75		192		112			13	94	88	9	14	8.6	20	6,080	15,900	6	3,500
LMEK60LUU		60		90		211	134	18			112	106	11	17.5	10.8	30	7,650	20,000	6	4,500	

★1 Dynamic load rating is based on the nominal life of 50km

★2 Based on the weight of resin retainer

★3 Main unit : mm

★4 1N ≒ 0.102kgf

★5 Steel retainer available from LMEK08L to LMEK30L only

LMEFP FLANGED LINEAR BUSHING

● Drawing

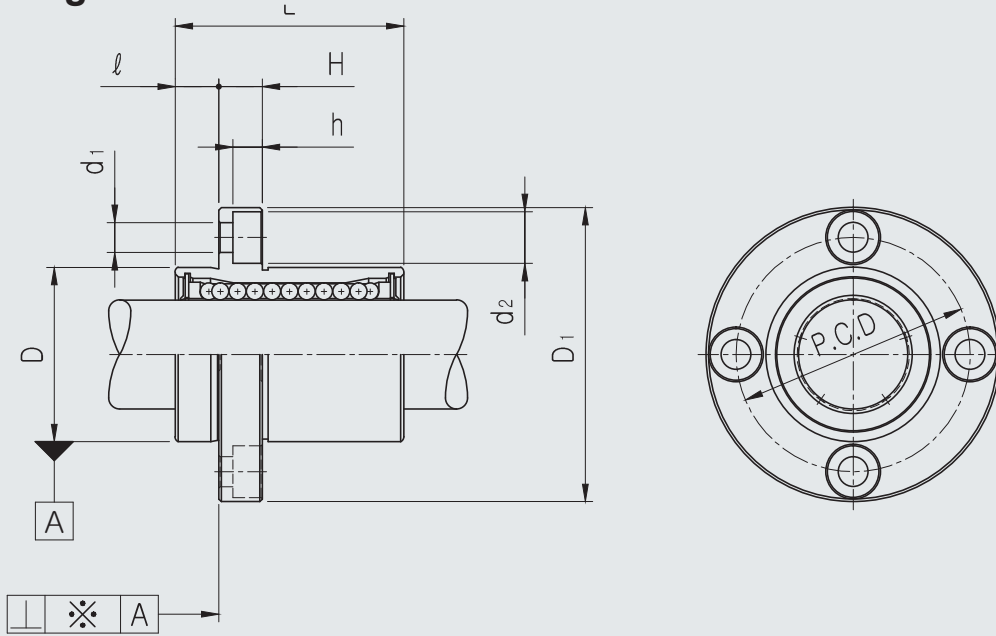

● Part Number Notation

LMEFP 20 UU - A N S



- European Standard Samick Circular Pilot Flanged Linear Bushing
- Nominal Shaft Diameter
- Seal

Blank	No Seal
UU	Both Side Seal
U	One Side Seal

- Retainer (material)

Blank	Resin Retainer(Standard)
A	Steel Retainer(High temperature) ^{★1}

- Outer-sleeves (by corrosion resistance)

Blank	Standard(SUJ2)
N	Electroless nickel plating
R	Raydent treatment

- Ball type (material)

Blank	Standard(High Carbon Chromium Bearing Steel Ball)
S	Stainless steel ball

★1 Steel retainer available from LMEFP08 to LMEFP30 only

LMEFP FLANGED LINEAR BUSHING

PART NUMBER		WORKING BORE DIAMETER		D		L		D ₁		ℓ	H	PCD	d ₁	d ₂	h	SQUARENESSE ※(μm)	BASIC LOAD RATING(N)		NO. OF BALL ROW	WEIGHT (gf) ^{★2}
Resin	Steel ^{★5}	dr. (mm)	Tolerance (mm)	mm	Tolerance (mm)	mm	Tolerance (mm)	mm	Tolerance (mm)								DYNAMIC (C) ^{★1}	STATIC (Co)		
LMEFP08UU	LMEFP08-A	8	+0.008 0	16	0 -0.008	25		32		5	5	24	3.4	6.5	3.2	12	260	400	4	44
LMEFP12UU	LMEFP12-A	12		22	0 -0.009	32	0 -0.2	42		6	6	32	4.5	8	4.2	12	410	590	4	86
LMEFP16UU	LMEFP16-A	16	+0.009 -0.001	26		36		46	0 -0.2	6	6	36	4.5	8	4.2	12	770	1,170	5	120
LMEFP20UU	LMEFP20-A	20		32		45		54		8	8	43	5.5	9.5	5.2	15	860	1,370	5	184
LMEFP25UU	LMEFP25-A	25	+0.011 -0.001	40	0 -0.011	58		62		8	8	51	5.5	9.5	5.2	15	980	1,560	6	335
LMEFP30UU	LMEFP30-A	30		47		68	0 -0.3	76		10	10	62	6.6	11	6.5	15	1,560	2,740	6	545
LMEFP40UU		40		62	0 -0.013	80		98		13	13	80	9	14	8.6	20	2,150	4,010	6	1,185
LMEFP50UU		50	+0.013 -0.002	75		100		112	0 -0.3	13	13	94	9	14	8.6	20	3,820	7,930	6	1,730
LMEFP60UU		60		90	0 -0.015	125	0 -0.4	134		18	18	112	11	17.5	10.8	25	4,700	9,990	6	3,180

- ★1 Dynamic load rating is based on the nominal life of 50km
- ★2 Based on the weight of resin retainer
- ★3 Main unit : mm
- ★4 1N ≒ 0.102kgf
- ★5 Steel retainer available from LMEFP08 to LMEFP30 only

LMEFP_L FLANGED LONG LINEAR BUSHING

● Drawing

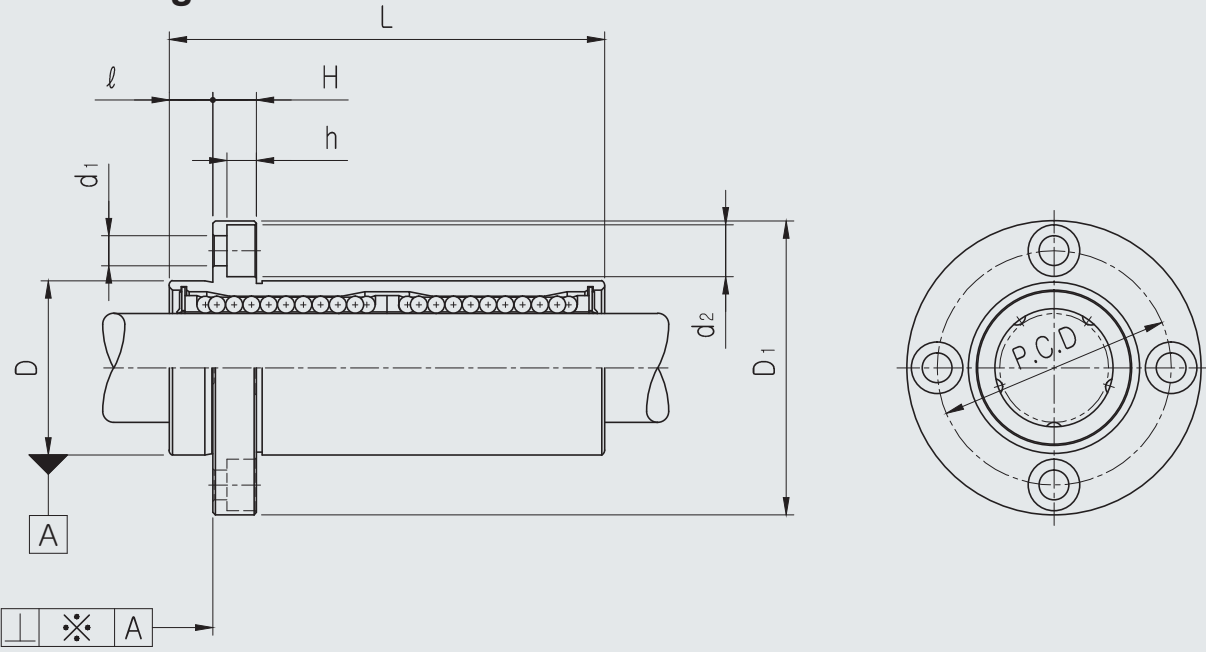

● Part Number Notation

LMEFP 20 L UU - A N S



- European Standard Samick Circular Pilot Flanged Linear Bushing
- Nominal Shaft Diameter
- Linear Bushing Long Type (for high load)
- Seal

Blank	No Seal
UU	Both Side Seal
U	One Side Seal

- Retainer (material)

Blank	Resin Retainer(Standard)
A	Steel Retainer(High temperature) ★1

- Outer-sleeves (by corrosion resistance)

Blank	Standard(SUJ2)
N	Electroless nickel plating
R	Raydent treatment

- Ball type (material)

Blank	Standard(High Carbon Chromium Bearing Steel Ball)
S	Stainless steel ball

★1 Steel retainer available from LMEFP08L to LMEFP30L only

LMEFP_L FLANGED LONG LINEAR BUSHING

PART NUMBER		WORKING BORE DIAMETER		D		L		D ₁		ℓ	H	PCD	d ₁	d ₂	h	SQUAR ENESS ※(μm) [*]	BASIC LOAD RATING(N)		NO. OF BALL ROW	WEIGHT (gf) ^{*2}
Resin	Steel ^{*5}	dr. (mm)	Tolerance (mm)	mm	Tolerance (mm)	mm	Tolerance (mm)	mm	Tolerance (mm)								DYNAMIC (C) ^{*1}	STATIC (Co)		
LMEFP08LUU	LMEFP08L-A	8	+0.009 -0.001	16	0 -0.009	45	0 -0.3	32	0 -0.2	5	5	24	3.4	6.5	3.2	15	430	780	4	53
LMEFP12LUU	LMEFP12L-A	12		22	0 -0.011	57		42		6	6	32	4.5	8	4.2	15	650	1,200	4	100
LMEFP16LUU	LMEFP16L-A	16	+0.011 -0.001	26	0 -0.013	70	0 -0.4	46	0 -0.3	6	6	36	4.5	8	4.2	15	1,230	2,350	5	187
LMEFP20LUU	LMEFP20L-A	20		32		80		54		8	8	43	5.5	9.5	5.2	17	1,400	2,750	5	260
LMEFP25LUU	LMEFP25L-A	25	+0.013 -0.002	40	0 -0.013	112	0 -0.4	62	0 -0.3	8	8	51	5.5	9.5	5.2	17	1,560	3,140	6	515
LMEFP30LUU	LMEFP30L-A	30		47	123	76		10		10	62	6.6	11	6.5	17	2,490	5,490	6	655	
LMEFP40LUU		40	+0.016 -0.004	62	0 -0.015	154	0 -0.4	98	0 -0.3	13	13	80	9	14	8.6	20	3,430	8,040	6	1,560
LMEFP50LUU		50		75	192	112		13		13	94	9	14	8.6	20	6,080	15,900	6	3,500	
LMEFP60LUU		60		90	0 -0.020	211		134		18	18	112	11	17.5	10.8	30	7,650	20,000	6	4,500

- ★1 Dynamic load rating is based on the nominal life of 50km
- ★2 Based on the weight of resin retainer
- ★3 Main unit : mm
- ★4 1N ≒ 0.102kgf
- ★5 Steel retainer available from LMEFP08L to LMEFP30L only

LMEKP FLANGED LINEAR BUSHING

● Drawing

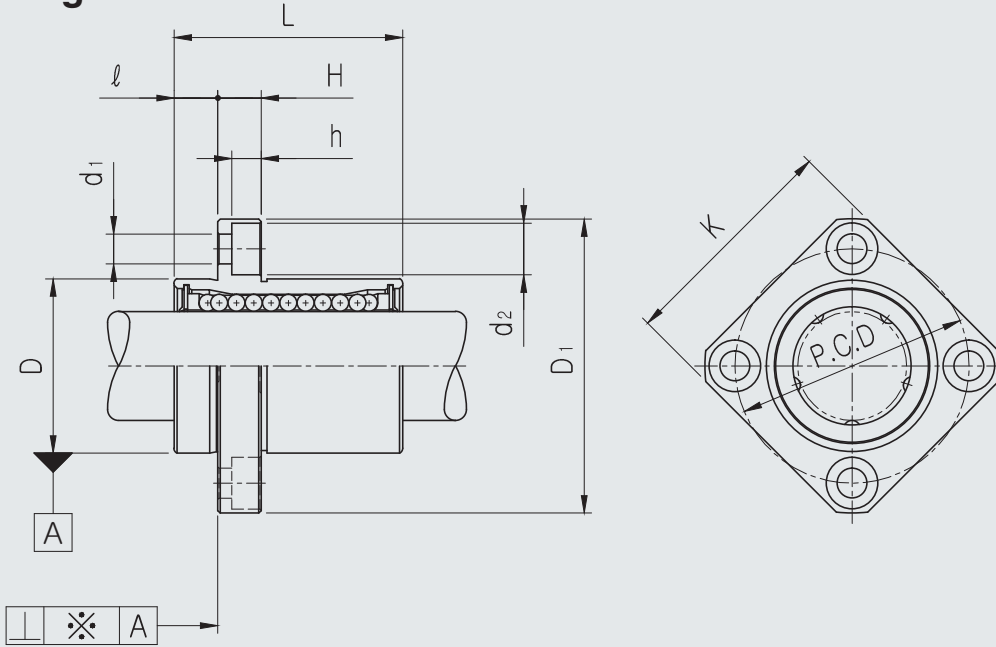

● Part Number Notation

LMEKP 20 UU - A N S

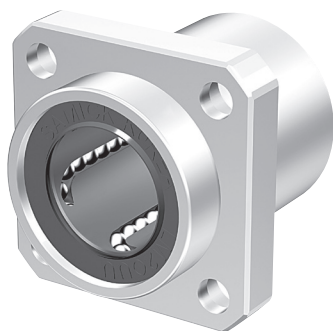

- European Standard Samick Squared Pilot Flanged Linear Bushing
- Nominal Shaft Diameter
- Seal

Blank	No Seal
UU	Both Side Seal
U	One Side Seal

- Retainer (material)

Blank	Resin Retainer(Standard)
A	Steel Retainer(High temperature) ^{★1}

- Outer-sleeves (by corrosion resistance)

Blank	Standard(SUJ2)
N	Electroless nickel plating
R	Raydent treatment

- Ball type (material)

Blank	Standard(High Carbon Chromium Bearing Steel Ball)
S	Stainless steel ball

★1 Steel retainer available from LMEKP08 to LMEKP30 only

LMEKP FLANGED LINEAR BUSHING

PART NUMBER		WORKING BORE DIAMETER		D		L		D ₁		ℓ	H	PCD	K	d ₁	d ₂	h	SQUARENESSE ※(μm) [★]	BASIC LOAD RATING(N)		NO. OF BALL ROW	WEIGHT (gf) ^{★2}
Resin	Steel ^{★5}	dr. (mm)	Tolerance (mm)	mm	Tolerance (mm)	mm	Tolerance (mm)	mm	Tolerance (mm)									DYNAMIC (C) ^{★1}	STATIC (Co)		
LMEKP08UU	LMEKP08-A	8	+0.008 0	16	0 -0.008	25	0 -0.2	32	0 -0.2	5	5	24	25	3.4	6.5	3.2	12	260	400	4	44
LMEKP12UU	LMEKP12-A	12		22	0 -0.009	32		42		6	6	32	32	4.5	8	4.2	12	410	590	4	86
LMEKP16UU	LMEKP16-A	16	+0.009 -0.001	26	0 -0.011	36	0 -0.3	46	0 -0.3	6	6	36	35	4.5	8	4.2	12	770	1,170	5	120
LMEKP20UU	LMEKP20-A	20		32		45		54		8	8	43	42	5.5	9.5	5.2	15	860	1,370	5	184
LMEKP25UU	LMEKP25-A	25	+0.011 -0.001	40	0 -0.013	58	0 -0.3	62	0 -0.3	8	8	51	50	5.5	9.5	5.2	15	980	1,560	6	335
LMEKP30UU	LMEKP30-A	30		47		68		76		10	10	62	60	6.6	11	6.5	15	1,560	2,740	6	545
LMEKP40UU		40	+0.013 -0.002	62	0 -0.015	80	0 -0.4	98	0 -0.4	13	13	80	75	9	14	8.6	20	2,150	4,010	6	1,185
LMEKP50UU		50		75		100		112		13	13	94	88	9	14	8.6	20	3,820	7,930	6	1,730
LMEKP60UU		60	90	125	134	18	18	112	106	11	17.5	10.8	25	4,700	9,990	6	3,180				

- ★1 Dynamic load rating is based on the nominal life of 50km
- ★2 Based on the weight of resin retainer
- ★3 Main unit : mm
- ★4 1N ≒ 0.102kgf
- ★5 Steel retainer available from LMEKP08 to LMEKP30 only

LMEKP_L FLANGED LONG LINEAR BUSHING

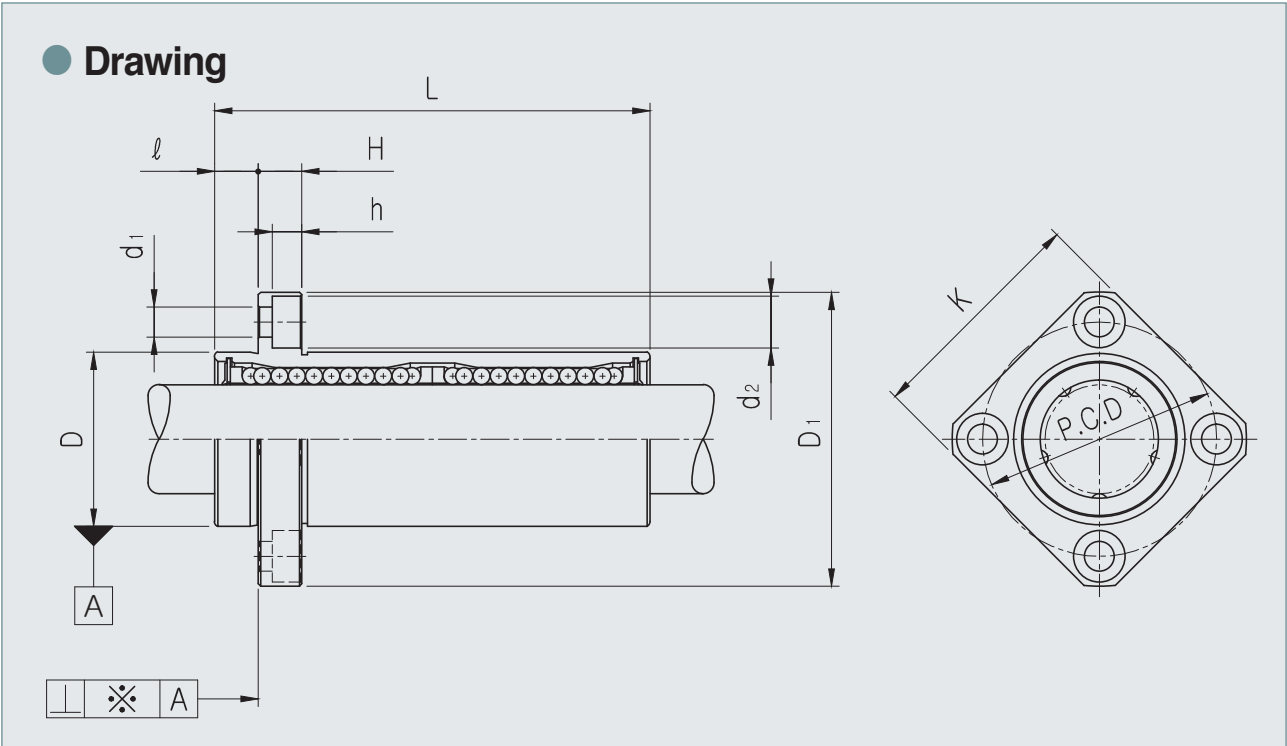

● **Part Number Notation**

LMEKP 20 L UU - A N S

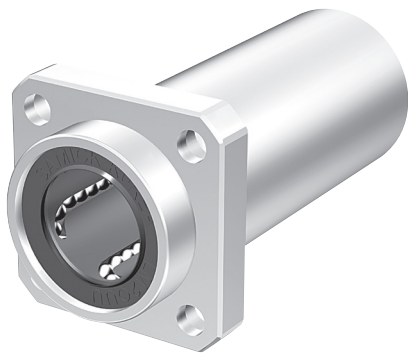

- European Standard Samick Square Pilot Flanged Linear Bushing
- Nominal Shaft Diameter
- Linear Bushing Long Type (for high load)
- Seal

Blank	No Seal
UU	Both Side Seal
U	One Side Seal

- Retainer (material)

Blank	Resin Retainer(Standard)
A	Steel Retainer(High temperature) ^{★1}

- Outer-sleeves (by corrosion resistance)

Blank	Standard(SUJ2)
N	Electroless nickel plating
R	Raydent treatment

- Ball type (material)

Blank	Standard(High Carbon Chromium Bearing Steel Ball)
S	Stainless steel ball

★1 Steel retainer available from LMEKP08L to LMEKP30L only

LMEKP_L FLANGED LONG LINEAR BUSHING

PART NUMBER		WORKING BORE DIAMETER		D		L		D ₁		ℓ	H	PCD	K	d ₁	d ₂	h	SQUAR ENESS ※(mm) [★]	BASIC LOAD RATING(N)		NO. OF BALL ROW	WEIGHT (gf) ^{★2}
Resin	Steel ^{★5}	dr. (mm)	Tolerance (mm)	mm	Tolerance (mm)	mm	Tolerance (mm)	mm	Tolerance (mm)								DYNAMIC (C) ^{★1}	STATIC (Co)			
LMEKP08LUU	LMEKP08L-A	8	+0.009 -0.001	16	0 -0.009	45	0 -0.3	32	0 -0.2	5	5	24	25	3.4	6.5	3.2	15	430	780	4	53
LMEKP12LUU	LMEKP12L-A	12		22	0 -0.011	57		42		6	6	32	32	4.5	8	4.2	15	650	1,200	4	100
LMEKP16LUU	LMEKP16L-A	16	+0.011 -0.001	26	0 -0.013	70	0 -0.4	46	0 -0.3	6	6	36	35	4.5	8	4.2	15	1,230	2,350	5	187
LMEKP20LUU	LMEKP20L-A	20		32		80		54		8	8	43	42	5.5	9.5	5.2	17	1,400	2,750	5	260
LMEKP25LUU	LMEKP25L-A	25	+0.013 -0.002	40	0 -0.015	112	0 -0.3	62	0 -0.2	8	8	51	50	5.5	9.5	5.2	17	1,560	3,140	6	515
LMEKP30LUU	LMEKP30L-A	30		47		123		76		10	10	62	60	6.6	11	6.5	17	2,490	5,490	6	655
LMEKP40LUU		40	+0.016 -0.004	62	0 -0.015	154	0 -0.3	98	0 -0.2	13	13	80	75	9	14	8.6	20	3,430	8,040	6	1,560
LMEKP50LUU		50		75		192		112		13	13	94	88	9	14	8.6	20	6,080	15,900	6	3,500
LMEKP60LUU		60		90	0 -0.020	211		134		18	18	112	106	11	17.5	10.8	30	7,650	20,000	6	4,500

- ★1 Dynamic load rating is based on the nominal life of 50km
- ★2 Based on the weight of resin retainer
- ★3 Main unit : mm
- ★4 1N ≒ 0.102kgf
- ★5 Steel retainer available from LMEKP08L to LMEKP30L only

LMEFM FLANGED LONG LINEAR BUSHING

● Drawing

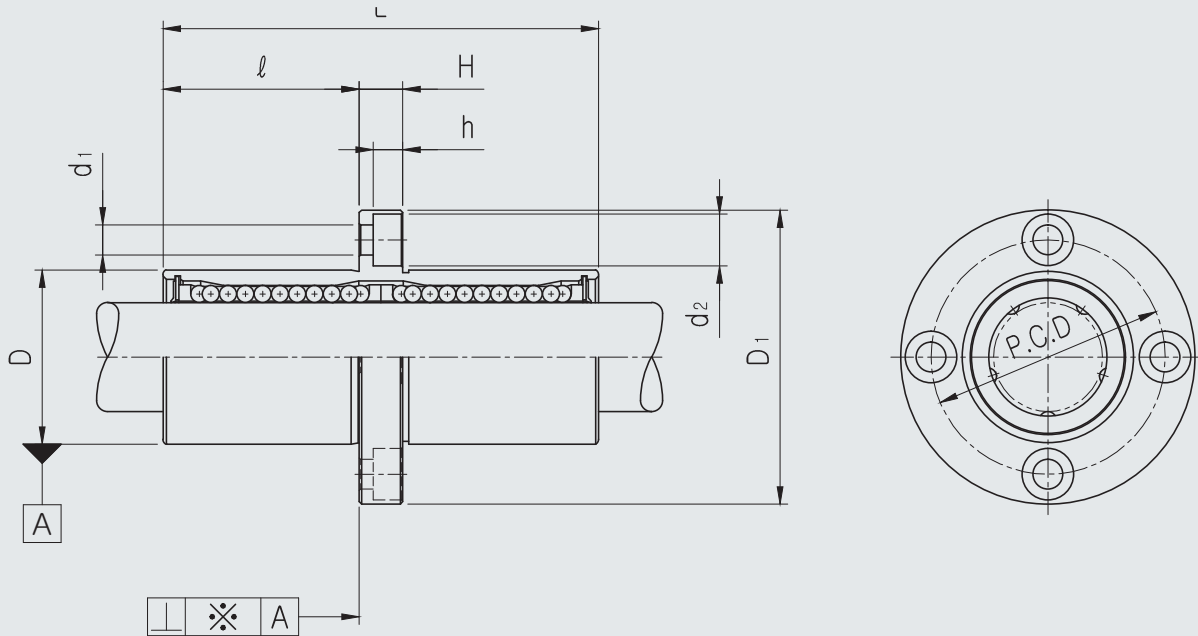

● Part Number Notation

LMEFM 20 UU - A N S



- European Standard Samick Circular Middle Flanged Linear Bushing
- Nominal Shaft Diameter
- Seal

Blank	No Seal
UU	Both Side Seal
U	One Side Seal

- Retainer (material)

Blank	Resin Retainer(Standard)
A	Steel Retainer(High temperature) ^{★1}

- Outer-sleeves (by corrosion resistance)

Blank	Standard(SUJ2)
N	Electroless nickel plating
R	Raydent treatment

- Ball type (material)

Blank	Standard(High Carbon Chromium Bearing Steel Ball)
S	Stainless steel ball

★1 Steel retainer available from LMEFM08 to LMEFM30 only

LMEFM FLANGED LONG LINEAR BUSHING

PART NUMBER		WORKING BORE DIAMETER		D		L		D ₁		ℓ	H	PCD	d ₁	d ₂	h	SQUAR ENESS ※(μm)	BASIC LOAD RATING(N)		NO. OF BALL ROW	WEIGHT (gf) ^{★2}
Resin	Steel ^{★5}	dr. (mm)	Tolerance (mm)	mm	Tolerance (mm)	mm	Tolerance (mm)	mm	Tolerance (mm)								DYNAMIC (C) ^{★1}	STATIC (Co)		
LMEFM08UU	LMEFM08-A	8	+0.009 -0.001	16	0 -0.009	45	0 -0.3	32	0 -0.2	20	5	24	3.4	6.5	3.2	15	430	780	4	53
LMEFM12UU	LMEFM12-A	12		22	0 -0.011	57		42		25.5	6	32	4.5	8	4.2	15	650	1,200	4	100
LMEFM16UU	LMEFM16-A	16	+0.011 -0.001	26	0 -0.013	70	0 -0.4	46	0 -0.3	32	6	36	4.5	8	4.2	15	1,230	2,350	5	187
LMEFM20UU	LMEFM20-A	20		32		80		54		36	8	43	5.5	9.5	5.2	17	1,400	2,750	5	260
LMEFM25UU	LMEFM25-A	25	+0.013 -0.002	40	0 -0.015	112	0 -0.4	62	0 -0.3	52	8	51	5.5	9.5	5.2	17	1,560	3,140	6	515
LMEFM30UU	LMEFM30-A	30		47		123		76		56.5	10	62	6.6	11	6.5	17	2,940	5,490	6	655
LMEFM40UU		40	+0.016 -0.004	62	0 -0.020	154	0 -0.4	98	0 -0.3	70.5	13	80	9	14	8.6	20	3,430	8,040	6	1,560
LMEFM50UU		50		75		192		112		89.5	13	94	9	14	8.6	20	6,080	15,900	6	3,500
LMEFM60UU		60		90		211		134		96.5	18	112	11	17.5	10.8	30	7,650	20,000	6	4,500

- ★1 Dynamic load rating is based on the nominal life of 50km
- ★2 Based on the weight of resin retainer
- ★3 Main unit : mm
- ★4 1N ≒ 0.102kgf
- ★5 Steel retainer available from LMEFM08 to LMEFM30 only

LMEKM FLANGED LONG LINEAR BUSHING

● Drawing

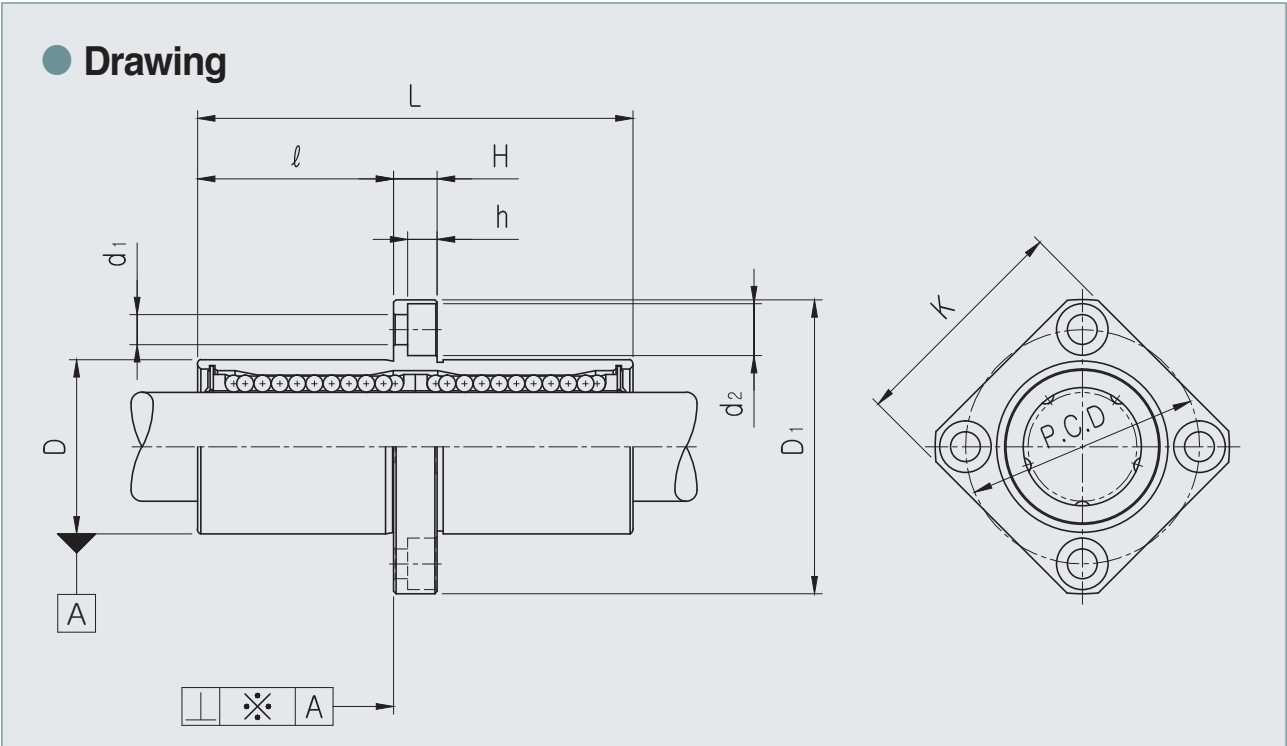

● Part Number Notation

LMEKM 20 UU - A N S



- European Standard Samick Square Middle Flanged Linear Bushing
- Nominal Shaft Diameter
- Seal

Blank	No Seal
UU	Both Side Seal
U	One Side Seal

- Retainer (material)

Blank	Resin Retainer(Standard)
A	Steel Retainer(High temperature) ^{★1}

- Outer-sleeves (by corrosion resistance)

Blank	Standard(SUJ2)
N	Electroless nickel plating
R	Raydent treatment

- Ball type (material)

Blank	Standard(High Carbon Chromium Bearing Steel Ball)
S	Stainless steel ball

★1 Steel retainer available from LMEKM08 to LMEKM30 only

LMEKM FLANGED LONG LINEAR BUSHING

PART NUMBER		WORKING BORE DIAMETER		D		L		D ₁		ℓ	H	PCD	K	d ₁	d ₂	h	SQUAR ENESS ※(μm)	BASIC LOAD RATING(N)		NO. OF BALL ROW	WEIGHT (g) ^{★2}
Resin	Steel ^{★5}	dr. (mm)	Tolerance (mm)	mm	Tolerance (mm)	mm	Tolerance (mm)	mm	Tolerance (mm)									DYNAMIC (C) ^{★1}	STATIC (Co)		
LMEKM08UU	LMEKM08-A	8	+0.009 -0.001	16	0 -0.009	45	0 -0.3	32	0 -0.2	20	5	24	25	3.4	6.5	3.2	15	430	780	4	53
LMEKM12UU	LMEKM12-A	12		22	0 -0.011	57		42		25.5	6	32	32	4.5	8	4.2	15	650	1,200	4	100
LMEKM16UU	LMEKM16-A	16	+0.011 -0.001	26	0 -0.013	70	0 -0.4	46	0 -0.3	32	6	36	35	4.5	8	4.2	15	1,230	2,350	5	187
LMEKM20UU	LMEKM20-A	20		32		80		54		36	8	43	42	5.5	9.5	5.2	17	1,400	2,750	5	260
LMEKM25UU	LMEKM25-A	25	+0.013 -0.002	40	0 -0.015	112	0 -0.4	62	0 -0.3	52	8	51	50	5.5	9.5	5.2	17	1,560	3,140	6	515
LMEKM30UU	LMEKM30-A	30		47		123		76		56.5	10	62	60	6.6	11	6.5	17	2,940	5,490	6	655
LMEKM40UU		40	+0.016 -0.004	62	0 -0.020	154	0 -0.4	98	0 -0.3	70.5	13	80	75	9	14	8.6	20	3,430	8,040	6	1,560
LMEKM50UU		50		75		192		112		89.5	13	94	88	9	14	8.6	20	6,080	15,900	6	3,500
LMEKM60UU		60		90		211		134		96.5	18	112	106	11	17.5	10.8	30	7,650	20,000	6	4,500

- ★1 Dynamic load rating is based on the nominal life of 50km
- ★2 Based on the weight of resin retainer
- ★3 Main unit : mm
- ★4 1N ≒ 0.102kgf
- ★5 Steel retainer available from LMEKM08 to LMEKM30 only



147

ALUMINUM CASE UNIT(SC, SCE, SCB, SLB)

SC ALUMINUM CASE UNIT

● Drawing

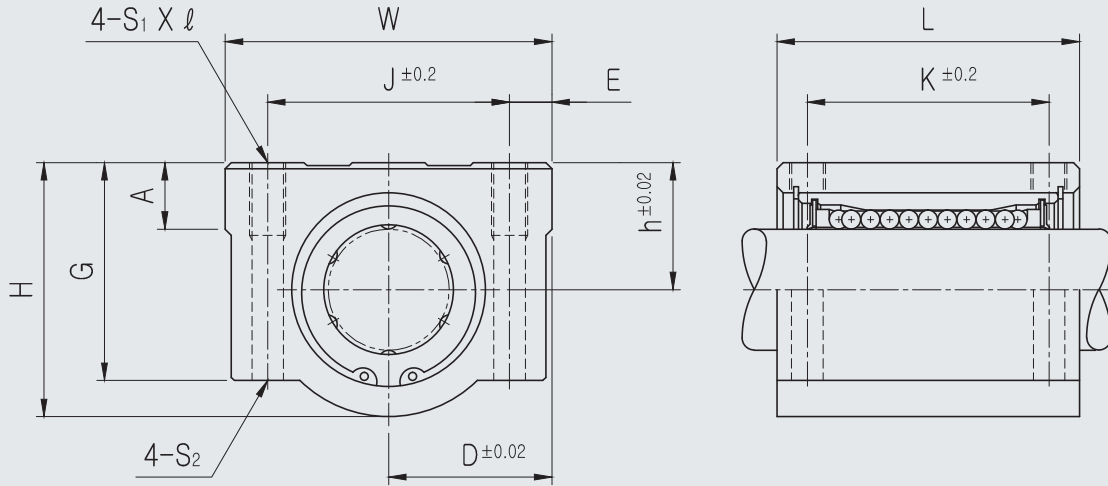

● Part Number Notation

SC 20 UU N - A N S



- Aluminum Case Unit
- Nominal Shaft Diameter
- Seal

Blank	No Seal
UU	Both Side Seal
U	One Side Seal

- New type
- Retainer (material)

Blank	Resin Retainer(Standard)
A	Steel Retainer(High temperature) ^{★1}

- Outer-sleeves (by corrosion resistance)

Blank	Standard(SUJ2)
N	Electroless nickel plating
R	Raydent treatment

- Ball type (material)

Blank	Standard(High Carbon Chromium Bearing Steel Ball)
S	Stainless steel ball

★1 Steel retainer available from SC08 to SC30 only

SC ALUMINUM CASE UNIT

PART NUMBER	L/B	h	D	W	H	G	A	J	E	S ₁ ×l	S ₂	K	L	BASIC LOAD RATING(N) ^{*4}		WEIGHT (gf) ^{*2}
														DYNAMIC (C) ^{*1}	STATIC (C ₀)	
SC08UU	LM08UU	11	17	34	22	18	6	24	5	M4×8	Ø3.4	18	30	260	400	56
SC10UU	LM10UU	13	20	40	26	21	8	28	6	M5×12	Ø4.3	21	35	370	540	90
SC12UU	LM12UU	15	22	44	30	24.5	8	33	5.5	M5×12	Ø4.3	26	39	410	590	112
SC12UUN	LM12UU	15	21	42	28	24	7.4	30.5	5.75	M5×12	Ø4.3	26	36	410	590	112
SC13UU	LM13UU	15	22	44	30	24.5	8	33	5.5	M5×12	Ø4.3	26	39	500	770	123
SC16UU	LM16UU	19	25	50	38.5	32.5	9	36	7	M5×12	Ø4.3	34	44	770	1,170	189
SC20UU	LM20UU	21	27	54	41	35	11	40	7	M6×12	Ø5.2	40	50	860	1,370	237
SC25UU	LM25UU	26	38	76	51.5	41	12	54	11	M8×18	Ø6.8	50	67	980	1,560	555
SC30UU	LM30UU	30	39	78	59.5	49	15	58	10	M8×18	Ø6.8	58	72	1,560	2,740	685
SC35UU	LM35UU	34	45	90	68	54	18	70	10	M8×18	Ø6.8	60	80	1,660	3,130	1,100
SC40UU	LM40UU	40	51	102	78	62	20	80	11	M10×25	Ø8.6	60	90	2,150	4,010	1,600
SC50UU	LM50UU	52	61	122	102	80	24	100	11	M10×25	Ø8.6	80	110	3,820	7,930	3,350

- ★1 Dynamic load rating is based on the nominal life of 50km
- ★2 Based on the weight of resin retainer
- ★3 Main unit : mm
- ★4 1N ≒ 0.102kgf
- ★5 Steel retainer applicable from SC08 to SC30 only

SCW ALUMINUM CASE UNIT LONG

● Drawing

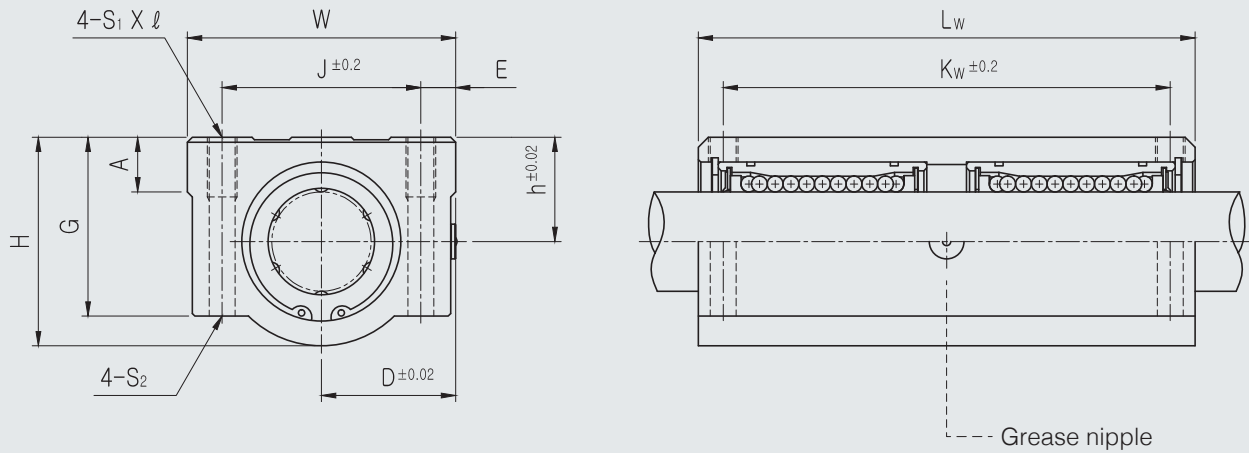

● Part Number Notation

SC 20 W UU - A N S



- Aluminum Case Unit
- Nominal Shaft Diameter
- Linear Bushing Long Type (for high load)
- Seal

Blank	No Seal
UU	Both Side Seal
U	One Side Seal

- Retainer (material)

Blank	Resin Retainer(Standard)
A	Steel Retainer(High temperature) ^{★1}

- Outer-sleeves (by corrosion resistance)

Blank	Standard(SUJ2)
N	Electroless nickel plating
R	Raydent treatment

- Ball type (material)

Blank	Standard(High Carbon Chromium Bearing Steel Ball)
S	Stainless steel ball

★1 Steel retainer available from SC08W to SC30W only

SCW ALUMINUM CASE UNIT LONG

PART NUMBER	L/B	h	D	W	H	G	A	J	E	S ₁ × <i>l</i>	S ₂	K _w	L _w	BASIC LOAD RATING(N) ^{*4}		WEIGHT (gf) ^{*2}
														DYNAMIC (C) ^{*1}	STATIC (Co)	
SC08WUU	LM08U×2	11	17	34	22	18	6	24	5	M4×8	Ø3.4	42	58	410	800	94
SC10WUU	LM10U×2	13	20	40	26	21	8	28	6	M5×10	Ø4.3	46	68	590	1,080	147
SC12WUU	LM12U×2	15	22	44	30	24.5	8	33	5.5	M5×10	Ø4.3	64	77	650	1,180	220
SC13WUU	LM13U×2	15	22	44	30	24.5	8	33	5.5	M5×10	Ø4.3	64	77	800	1,540	245
SC16WUU	LM16U×2	19	25	50	38.5	32.5	9	36	7	M5×12	Ø4.3	79	89	1,230	2,340	376
SC20WUU	LM20U×2	21	27	54	41	35	11	40	7	M6×12	Ø5.2	90	100	1,370	2,740	476
SC25WUU	LM25U×2	26	38	76	51.5	41	12	54	11	M8×18	Ø6.8	119	136	1,560	3,120	1,115
SC30WUU	LM30U×2	30	39	78	59.5	49	15	58	10	M8×18	Ø6.8	132	146	2,490	5,480	1,375
SC35WUU	LM35U×2	34	45	90	68	54	18	70	10	M8×18	Ø6.8	140	160	2,650	6,260	2,200
SC40WUU	LM40U×2	40	51	102	78	62	20	80	11	M10×25	Ø8.6	150	180	3,440	8,020	3,200
SC50WUU	LM50U×2	52	61	122	102	80	24	100	11	M10×25	Ø8.6	200	230	6,110	15,860	6,720

★1 Dynamic load rating is based on the nominal life of 50km

★2 Based on the weight of resin retainer

★3 Main unit : mm

★4 1N ≒ 0.102kgf

★5 Steel retainer applicable from SC08W to SC30W only

SCW_N ALUMINUM CASE UNIT LONG

● Drawing

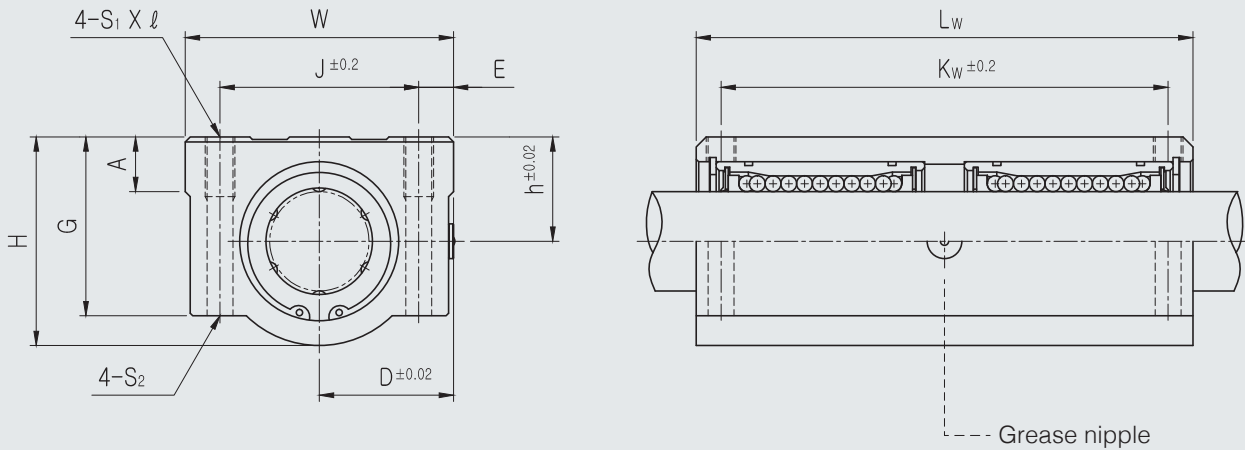

● Part Number Notation

SC 20 W UU N - A N S



- Aluminum Case Unit
- Nominal Shaft Diameter
- Linear Bushing Long Type (for high load)
- Seal

Blank	No Seal
UU	Both Side Seal
U	One Side Seal

- New type
- Retainer (material)

Blank	Resin Retainer(Standard)
A	Steel Retainer(High temperature) ★1

- Outer-sleeves (by corrosion resistance)

Blank	Standard(SUJ2)
N	Electroless nickel plating
R	Raydent treatment

- Ball type (material)

Blank	Standard(High Carbon Chromium Bearing Steel Ball)
S	Stainless steel ball

★1 Steel retainer available from SC08WN to SC30WN only

SCW_N ALUMINUM CASE UNIT LONG

PART NUMBER	L/B	h	D	W	H	G	A	J	E	S ₁ ×ℓ	S ₂	K _w	L _w	BASIC LOAD RATING(N) ^{*4}		WEIGHT (gf) ^{*2}
														DYNAMIC (C) ^{*1}	STATIC (C ₀)	
SC08WUUN	LM08Ux2	11	17	34	22	18	6	24	5	M4x8	Ø3.4	42	58	410	800	94
SC10WUUN	LM10Ux2	13	20	40	26	21	8	28	6	M5x12	Ø4.3	46	68	590	1,080	147
SC12WUUN	LM12Ux2	15	21	42	28	24	7.4	30.5	5.75	M5x12	Ø4.3	50	70	650	1,180	220
SC13WUUN	LM13Ux2	15	22	44	30	24.5	8	33	5.5	M5x12	Ø4.3	50	75	800	1,540	245
SC16WUUN	LM16Ux2	19	25	50	38.5	32.5	9	36	7	M5x12	Ø4.3	60	85	1,230	2,340	376
SC20WUUN	LM20Ux2	21	27	54	41	35	11	40	7	M6x12	Ø5.2	70	96	1,370	2,740	476
SC25WUUN	LM25Ux2	26	38	76	51.5	41	12	54	11	M8x18	Ø6.8	100	130	1,560	3,120	1,115
SC30WUUN	LM30Ux2	30	39	78	59.5	49	15	58	10	M8x18	Ø6.8	110	140	2,490	5,480	1,375
SC35WUUN	LM35Ux2	34	45	90	68	54	18	70	10	M8x18	Ø6.8	120	155	2,650	6,260	2,200
SC40WUUN	LM40Ux2	40	51	102	78	62	20	80	11	M10x25	Ø8.6	140	175	3,440	8,020	3,200
SC50WUUN	LM50Ux2	52	61	122	102	80	24	100	11	M10x25	Ø8.6	160	215	6,110	15,860	6,720

- ★1 Dynamic load rating is based on the nominal life of 50km
- ★2 Based on the weight of resin retainer
- ★3 Main unit : mm
- ★4 1N ≒ 0.102kgf
- ★5 Steel retainer applicable from SC08WN to SC30WN only

SCV ALUMINUM CASE UNIT

● Drawing

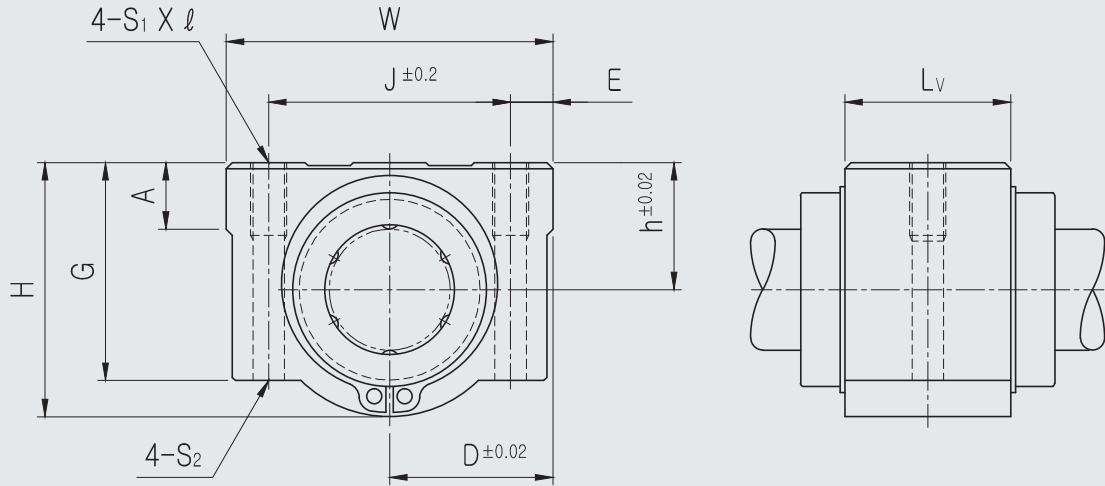

● Part Number Notation

SC 20 V UU N - A N S

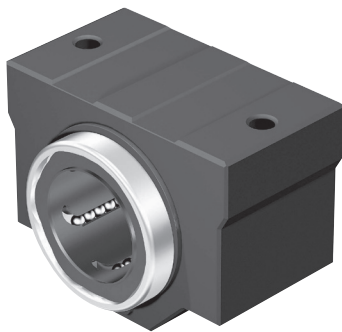

- Aluminum Case Unit
- Nominal Shaft Diameter
- Compact type
- Seal

Blank	No Seal
UU	Both Side Seal
U	One Side Seal

- New type
- Retainer (material)

Blank	Resin Retainer(Standard)
A	Steel Retainer(High temperature) ^{★1}

- Outer-sleeves (by corrosion resistance)

Blank	Standard(SUJ2)
N	Electroless nickel plating
R	Raydent treatment

- Ball type (material)

Blank	Standard(High Carbon Chromium Bearing Steel Ball)
S	Stainless steel ball

★1 Steel retainer available from SC08V to SC30V only

SCV ALUMINUM CASE UNIT

PART NUMBER	L/B	h	D	W	H	G	A	J	E	S ₁ ×ℓ	S ₂	L _w	BASIC LOAD RATING(N) ^{*4}		WEIGHT (gf) ^{*2}
													DYNAMIC (C) ^{*1}	STATIC (C ₀)	
SC08VUU	LM08UU	11	17	34	22	18	6	24	5	M4×8	Ø3.4	15.4	260	400	36
SC10VUU	LM10UU	13	20	40	26	21	8	28	6	M5×10	Ø4.3	19.5	370	540	63
SC12VUU	LM12UU	15	22	44	30	24.5	8	33	5.5	M5×12	Ø4.3	20.5	410	590	74
SC12VUUN	LM12UU	15	21	42	28	24	7.4	30.5	5.75	M5×12	Ø4.3	20.5	410	590	74
SC13VUU	LM13UU	15	22	44	30	24.5	8	33	5.5	M5×12	Ø4.3	20.5	500	770	85
SC16VUU	LM16UU	19	25	50	38.5	32.5	9	36	7	M5×12	Ø4.3	23.5	770	1,170	132
SC20VUU	LM20UU	21	27	54	41	35	11	40	7	M6×12	Ø5.2	27.4	860	1,370	170
SC25VUU	LM25UU	26	38	76	51.5	41	12	54	11	M8×18	Ø6.8	37.4	980	1,560	405
SC30VUU	LM30UU	30	39	78	59.5	49	15	58	10	M8×18	Ø6.8	40.9	1,560	2,740	495
SC35VUU	LM35UU	34	45	90	68	54	18	70	10	M8×18	Ø6.8	45.4	1,660	3,130	790
SC40VUU	LM40UU	40	51	102	78	62	20	80	11	M10×25	Ø8.6	56.4	2,150	4,010	1,220
SC50VUU	LM50UU	52	61	122	102	80	24	100	11	M10×25	Ø8.6	68.9	3,820	7,930	2,300

- ★1 Dynamic load rating is based on the nominal life of 50km
- ★2 Based on the weight of resin retainer
- ★3 Main unit : mm
- ★4 1N ≒ 0.102kgf
- ★5 Steel retainer applicable from SC08V to SC30V only

SCJ ADJUSTABLE ALUMINUM CASE UNIT

● Drawing

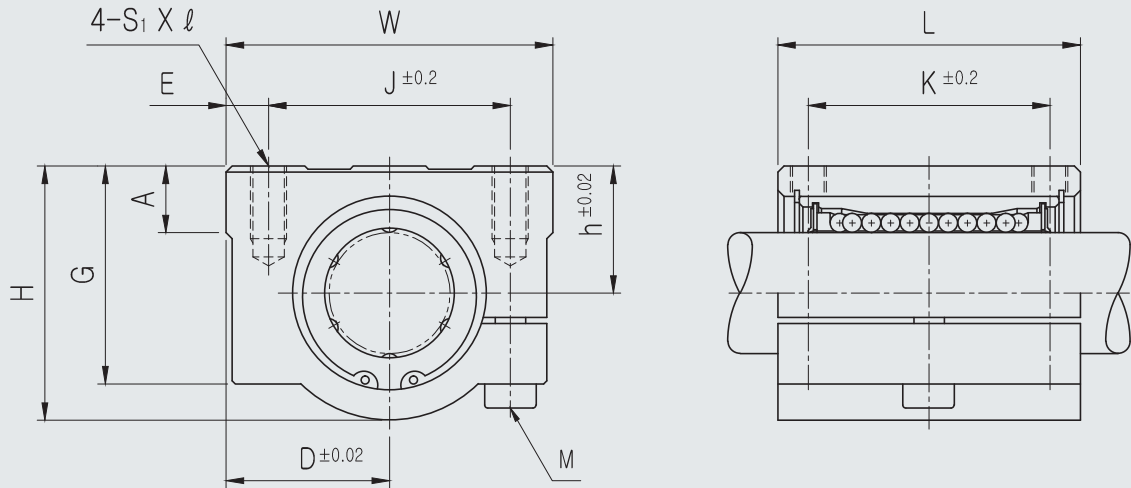

● Part Number Notation

SCJ 20 UU - A N S

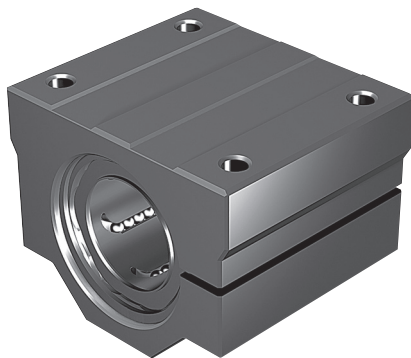

- Aluminum Case Unit(Adjustable type)
- Nominal Shaft Diameter
- Seal

Blank	No Seal
UU	Both Side Seal
U	One Side Seal

- Retainer (material)

Blank	Resin Retainer(Standard)
A	Steel Retainer(High temperature) ^{★1}

- Outer-sleeves (by corrosion resistance)

Blank	Standard(SUJ2)
N	Electroless nickel plating
R	Raydent treatment

- Ball type (material)

Blank	Standard(High Carbon Chromium Bearing Steel Ball)
S	Stainless steel ball

★1 Steel retainer available from SCJ10 to SCJ30 only

SCJ ADJUSTABLE ALUMINUM CASE UNIT

PART NUMBER	L/B	h	D	W	H	G	A	J	E	S ₁ × <i>l</i>	K	L	M	BASIC LOAD RATING(N) ^{*4}		OUTER DIAMETER	WEIGHT (g) ^{*2}
														DYNAMIC (C) ^{*1}	STATIC (Co)		
SCJ10UU	LM10UUAJ	13	20	40	26	21	8	28	6	M5×12	21	35	M4	370	540	Ø10	90
SCJ12UU	LM12UUAJ	15	21	42	28	24	7.4	30.5	5.75	M5×12	26	36	M4	410	590	Ø12	112
SCJ13UU	LM13UUAJ	15	22	44	30	24.5	8	33	5.5	M5×12	26	39	M4	500	770	Ø13	123
SCJ16UU	LM16UUAJ	19	25	50	38.5	32.5	9	36	7	M5×12	34	44	M4	770	1,170	Ø16	189
SCJ20UU	LM20UUAJ	21	27	54	41	35	11	40	7	M6×12	40	50	M5	860	1,370	Ø20	237
SCJ25UU	LM25UUAJ	26	38	76	51.5	41	12	54	11	M8×18	50	67	M6	980	1,560	Ø25	555
SCJ30UU	LM30UUAJ	30	39	78	59.5	49	15	58	10	M8×18	58	72	M6	1,560	2,740	Ø30	685
SCJ35UU	LM35UUAJ	34	45	90	68	54	18	70	10	M8×18	60	80	M6	1,660	3,130	Ø35	1,100
SCJ40UU	LM40UUAJ	40	51	102	78	62	20	80	11	M10×25	60	90	M8	2,150	4,010	Ø40	1,600
SCJ50UU	LM50UUAJ	52	61	122	102	80	24	100	11	M10×25	80	110	M8	3,820	7,930	Ø50	3,350

- ★1 Dynamic load rating is based on the nominal life of 50km
- ★2 Based on the weight of resin retainer
- ★3 Main unit : mm
- ★4 1N ≒ 0.102kgf
- ★5 Steel retainer applicable from SCJ10 to SCJ30 only

SBR ALUMINUM CASE UNIT OPEN

● Drawing

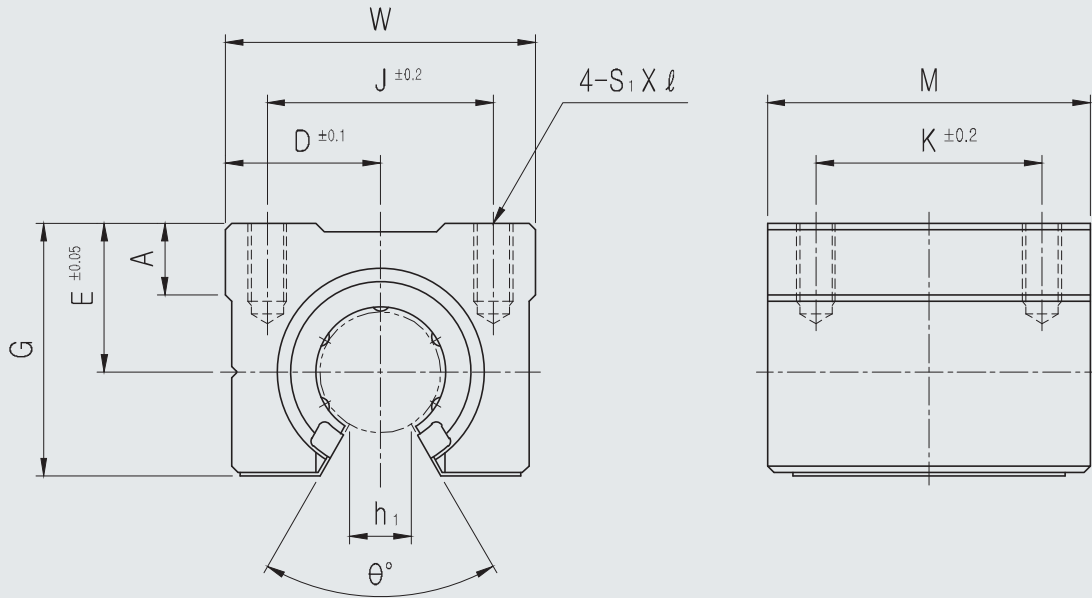

● Part Number Notation

SBR 20 UU - N S

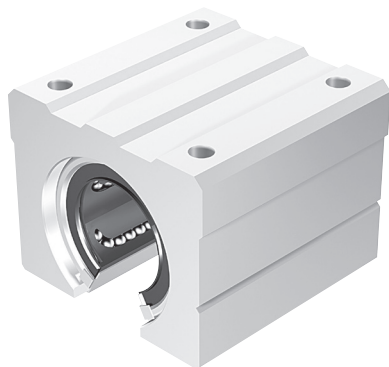

● Aluminum Case Unit(Open type)

● Nominal Shaft Diameter

● Seal

UU	Both Side Seal ^{★1}
----	------------------------------

● Outer-sleeves (by corrosion resistance)

Blank	Standard(SUJ2)
N	Electroless nickel plating
R	Raydent treatment

● Ball type (material)

Blank	Standard(High Carbon Chromium Bearing Steel Ball)
S	Stainless steel ball

※ ★1 UU type only available.

No seal type & One side seal type not available.

★ Resin retainer only available

SBR ALUMINUM CASE UNIT OPEN

PART NUMBER	L/B	D	W	G	θ	A	M	S ₁ ×ℓ	h ₁	E	J	K	BASIC LOAD RATING(N) ^{★4}		WEIGHT (gf) ^{★2}
													DYNAMIC (C) ^{★1}	STATIC (Co)	
SBR16UU	LM16UUOP	22.5	45	33	80°	9	45	M5×12	11	20	32	30	770	1,170	150
SBR20UU	LM20UUOP	24	48	39	60°	11	50	M6×12	11	23	35	35	860	1,370	200
SBR25UU	LM25UUOP	30	60	47	50°	14	65	M6×12	12	27	40	40	980	1,560	450
SBR30UU	LM30UUOP	35	70	56	50°	15	70	M8×18	15	33	50	50	1,560	2,740	630
SBR35UU	LM35UUOP	40	80	63	50°	18	80	M8×18	17	37	55	55	1,660	3,130	920
SBR40UU	LM40UUOP	45	90	72	50°	20	90	M10×20	20	42	65	65	2,150	4,010	1,330
SBR50UU	LM50UUOP	60	120	91	50°	25	110	M10×20	25	53	94	80	3,820	7,930	3,000

★1 Dynamic load rating is based on the nominal life of 50km

★2 Based on the weight of resin retainer

★3 Main unit : mm

★4 1N ≒ 0.102kgf

TBR ALUMINUM CASE UNIT OPEN

● Drawing

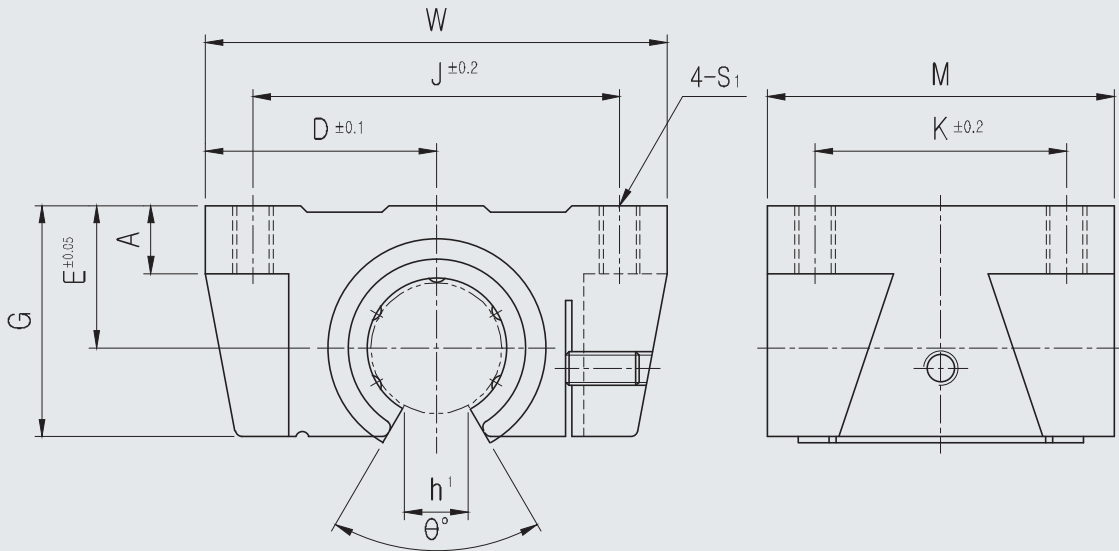

● Part Number Notation

TBR 20 UU - N S

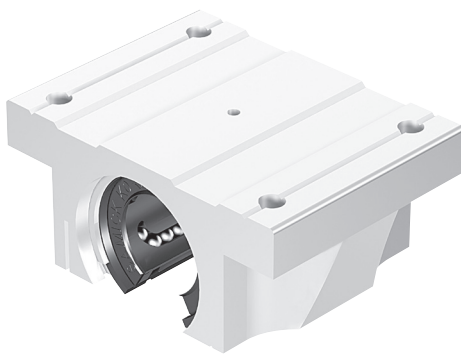

- Aluminum Case Unit(Open type)
- Nominal Shaft Diameter
- Seal

Blank	No Seal
UU	Both Side Seal
U	One Side Seal

- Outer-sleeves (by corrosion resistance)

Blank	Standard(SUJ2)
N	Electroless nickel plating
R	Raydent treatment

- Ball type (material)

Blank	Standard(High Carbon Chromium Bearing Steel Ball)
S	Stainless steel ball

TBR ALUMINUM CASE UNIT OPEN

PART NUMBER	L/B	D	W	G	θ	A	M	S ₁	h ₁	E	J	K	BASIC LOAD RATING(N) ^{*4}		WEIGHT (gf) ^{*2}
													DYNAMIC (C) ^{*1}	STATIC (Co)	
TBR16UU	LM16UUOP	31	62	26	80°	8	42	M5	11	18	50	30	770	1,170	180
TBR20UU	LM20UUOP	34	68	31	60°	10	51	M6	11	21	54	37	860	1,370	300
TBR25UU	LM25UUOP	41	82	41	50°	12	65	M8	12	28	65	50	980	1,560	600
TBR30UU	LM30UUOP	45.5	91	48	50°	12	75	M8	15	34	75	60	1,560	2,740	900

★1 Dynamic load rating is based on the nominal life of 50km

★2 Based on the weight of resin retainer

★3 Main unit : mm

★4 1N \approx 0.102kgf

SCE ALUMINUM CASE UNIT

● Drawing

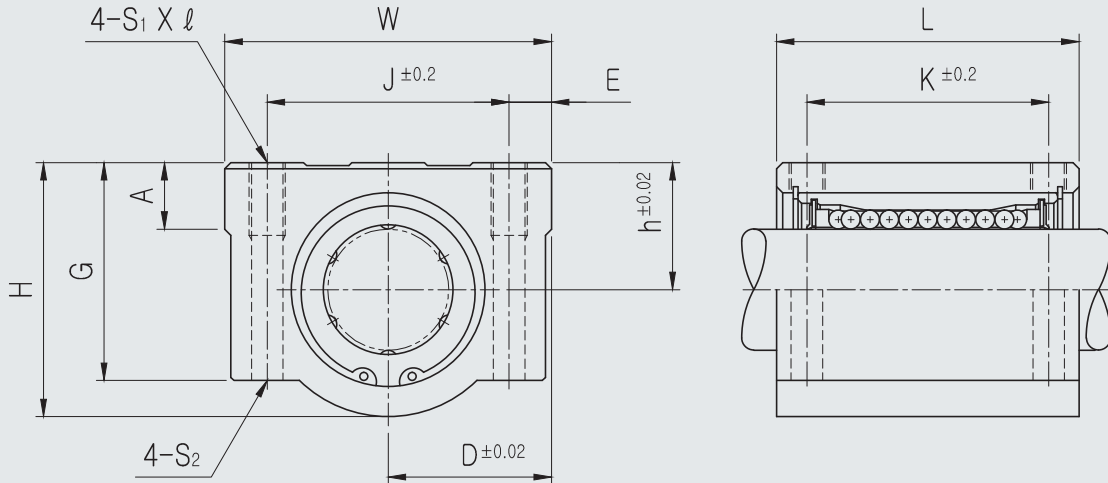

● Part Number Notation

SCE 20 UU - A N S



- European Standard Aluminum Case Unit
- Nominal Shaft Diameter
- Seal

Blank	No Seal
UU	Both Side Seal
U	One Side Seal

- Retainer (material)

Blank	Resin Retainer(Standard)
A	Steel Retainer(High temperature) ^{★1}

- Outer-sleeves (by corrosion resistance)

Blank	Standard(SUJ2)
N	Electroless nickel plating
R	Raydent treatment

- Ball type (material)

Blank	Standard(High Carbon Chromium Bearing Steel Ball)
S	Stainless steel ball

★1 Steel retainer available from SCE08 to SCE30 only

SCE ALUMINUM CASE UNIT

PART NUMBER	L/B	h	D	W	H	G	A	J	E	S ₁ ×l	S ₂	K	L	BASIC LOAD RATING(N) ^{*4}		WEIGHT (gf) ^{*2}
														DYNAMIC (C) ^{*1}	STATIC (C ₀)	
SCE08UU	LME08UU	11	17	34	22	18	6	24	5	M4×8	Ø3.4	18	30	260	400	60
SCE12UU	LME12UU	15	22	44	30	24.5	8	33	5.5	M5×10	Ø4.3	26	39	410	590	118
SCE16UU	LME16UU	19	25	50	38.5	32.5	9	36	7	M5×12	Ø4.3	34	44	770	1,170	180
SCE20UU	LME20UU	21	27	54	41	35	11	40	7	M6×12	Ø5.2	40	53	860	1,370	245
SCE25UU	LME25UU	26	38	76	51.5	41	12	54	11	M8×18	Ø6.8	50	67	980	1,560	550
SCE30UU	LME30UU	30	39	78	59.5	49	15	58	10	M8×18	Ø6.8	58	76	1,560	2,740	760
SCE40UU	LME40UU	40	51	102	78	62	20	80	11	M10×25	Ø8.6	60	90	2,150	4,010	1,700
SCE50UU	LME50UU	52	61	122	102	80	24	100	11	M10×25	Ø8.6	80	110	3,820	7,930	2,950

- ★1 Dynamic load rating is based on the nominal life of 50km
- ★2 Based on the weight of resin retainer
- ★3 Main unit : mm
- ★4 1N ≒ 0.102kgf
- ★5 Steel retainer applicable from SCE08 to SCE30 only

SCE_W ALUMINUM CASE UNIT LONG

● Drawing

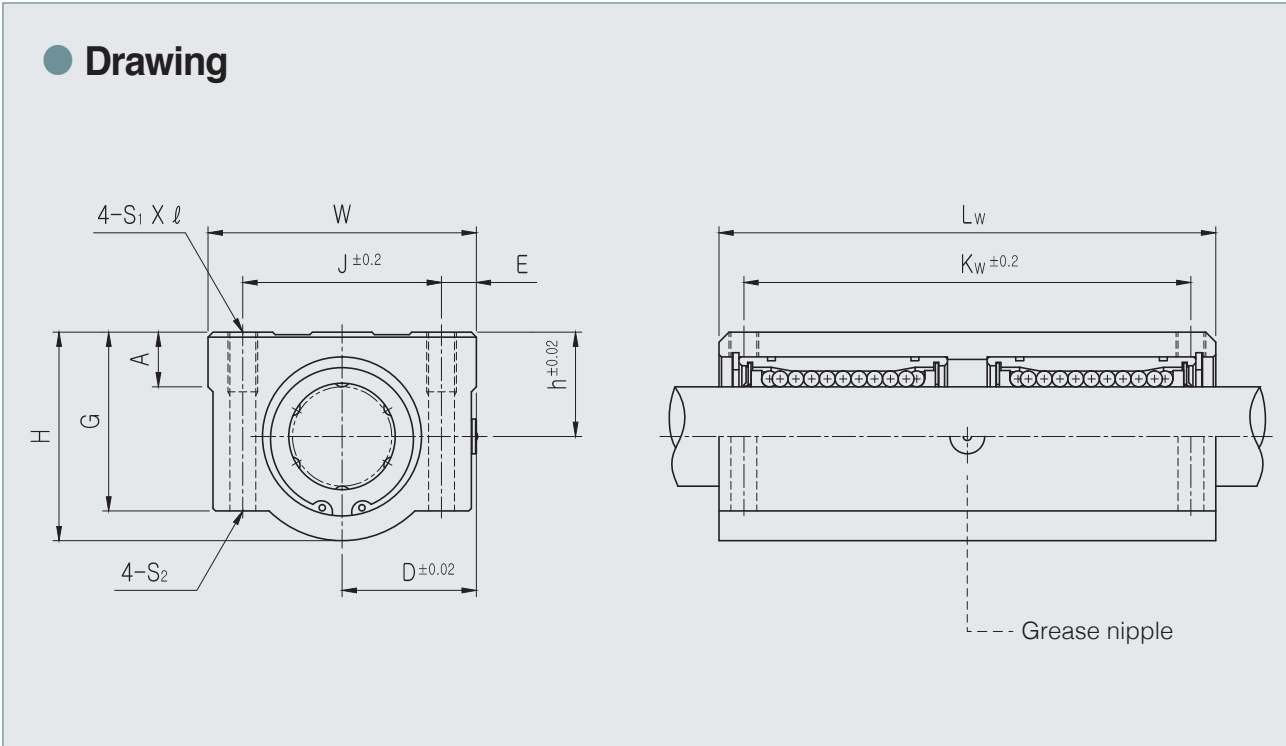

● Part Number Notation

SCE 20 W UU - A N S



- Aluminum Case Unit
- Nominal Shaft Diameter
- Linear Bushing Long Type (for high load)
- Seal

Blank	No Seal
UU	Both Side Seal
U	One Side Seal

- Retainer (material)

Blank	Resin Retainer(Standard)
A	Steel Retainer(High temperature)★1

- Outer-sleeves (by corrosion resistance)

Blank	Standard(SUJ2)
N	Electroless nickel plating
R	Raydent treatment

- Ball type (material)

Blank	Standard(High Carbon Chromium Bearing Steel Ball)
S	Stainless steel ball

★1 Steel retainer available from SCE08W to SCE30W only

SCE_W ALUMINUM CASE UNIT LONG

PART NUMBER	L/B	h	D	W	H	G	A	J	E	S ₁ ×l	S ₂	K _w	L _w	BASIC LOAD RATING(N) ^{*4}		WEIGHT (gf) ^{*2}
														DYNAMIC (C) ^{*1}	STATIC (C ₀)	
SCE08WUU	LME08U×2	11	17	34	22	18	6	24	5	M4×8	Ø3.4	42	58	410	800	98
SCE12WUU	LME12U×2	15	22	44	30	24.5	8	33	5.5	M5×10	Ø4.3	64	77	650	1,180	232
SCE16WUU	LME16U×2	19	25	50	38.5	32.5	9	36	7	M5×12	Ø4.3	79	89	1,230	2,340	360
SCE20WUU	LME20U×2	21	27	54	41	35	11	40	7	M6×12	Ø5.2	90	106	1,370	2,740	490
SCE25WUU	LME25U×2	26	38	76	51.5	41	12	54	11	M8×18	Ø6.8	119	136	1,560	3,120	1,100
SCE30WUU	LME30U×2	30	39	78	59.5	49	15	58	10	M8×18	Ø6.8	132	154	2,490	5,480	1,525
SCE40WUU	LME40U×2	40	51	102	78	62	20	80	11	M10×25	Ø8.6	150	180	3,440	8,020	3,400
SCE50WUU	LME50U×2	52	61	122	102	80	24	100	11	M10×25	Ø8.6	200	230	6,110	15,860	5,920

- ★1 Dynamic load rating is based on the nominal life of 50km
- ★2 Based on the weight of resin retainer
- ★3 Main unit : mm
- ★4 1N ≒ 0.102kgf
- ★5 Steel retainer applicable from SCE08W to SCE30W only

SCE_V ALUMINUM CASE UNIT

● Drawing

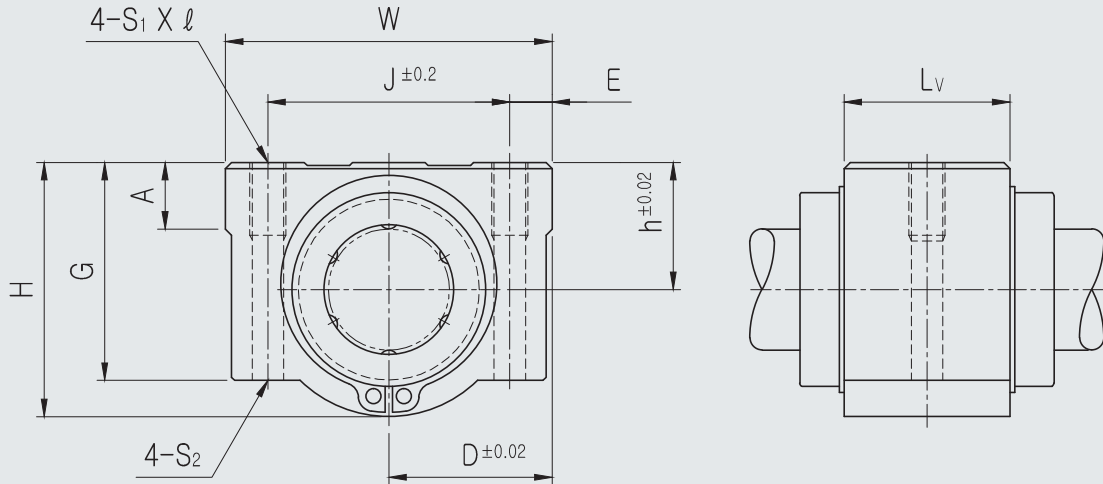

● Part Number Notation

SCE 20 V UU - A N S

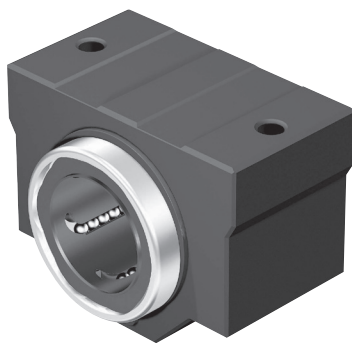

- European Standard Aluminum Case Unit
- Nominal Shaft Diameter
- Compact type
- Seal

Blank	No Seal
UU	Both Side Seal
U	One Side Seal

- Retainer (material)

Blank	Resin Retainer(Standard)
A	Steel Retainer(High temperature) ★1

- Outer-sleeves (by corrosion resistance)

Blank	Standard(SUJ2)
N	Electroless nickel plating
R	Raydent treatment

- Ball type (material)

Blank	Standard(High Carbon Chromium Bearing Steel Ball)
S	Stainless steel ball

★1 Steel retainer available from SCE08V to SCE30V only

SCE_V ALUMINUM CASE UNIT

PART NUMBER	L/B	h	D	W	H	G	A	J	E	S ₁ × <i>l</i>	S ₂	L _w	BASIC LOAD RATING(N) ^{*4}		WEIGHT (gf) ^{*2}
													DYNAMIC (C) ^{*1}	STATIC (Co)	
SCE08VUU	LME08UU	11	17	34	22	18	6	24	5	M4×8	Ø3.4	14.4	260	400	40
SCE12VUU	LME12UU	15	22	44	30	24.5	8	33	5.5	M5×10	Ø4.3	20.3	410	590	82
SCE16VUU	LME16UU	19	25	50	38.5	32.5	9	36	7	M5×12	Ø4.3	22.3	770	1,170	122
SCE20VUU	LME20UU	21	27	54	41	35	11	40	7	M6×12	Ø5.2	28.3	860	1,370	176
SCE25VUU	LME25UU	26	38	76	51.5	41	12	54	11	M8×18	Ø6.8	40.4	980	1,560	400
SCE30VUU	LME30UU	30	39	78	59.5	49	15	58	10	M8×18	Ø6.8	48.4	1,560	2,740	570
SCE40VUU	LME40UU	40	51	102	78	62	20	80	11	M10×25	Ø8.6	56.4	2,150	4,010	1,320
SCE50VUU	LME50UU	52	61	122	102	80	24	100	11	M10×25	Ø8.6	72.3	3,820	7,930	1,900

- ★1 Dynamic load rating is based on the nominal life of 50km
- ★2 Based on the weight of resin retainer
- ★3 Main unit : mm
- ★4 1N ≒ 0.102kgf
- ★5 Steel retainer applicable from SCE08V to SCE30V only

SCB ALUMINUM CASE UNIT

● Drawing

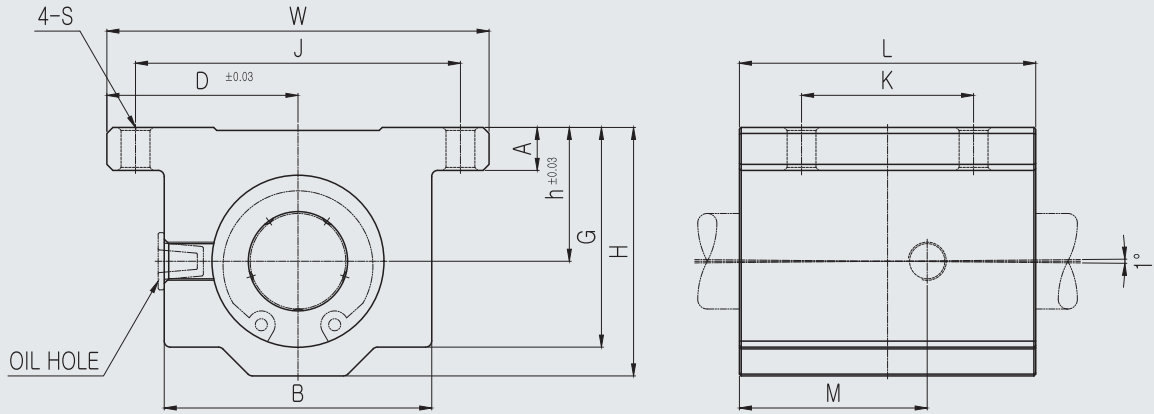

● Part Number Notation

SCB 20 UU - N S



● Aluminum Case Unit
Self-Aligning Linear Bushing(inch type)

● Nominal Shaft Diameter

● Seal

Blank	No Seal
UU	Both Side Seal
U	One Side Seal

● Corrosion resistance type

Blank	Stainless steel
N	Electroless nicked plating

● Ball type (material)

Blank	Standard(High Carbon Chromium Bearing Steel Ball)
S	Stainless steel ball

SCB ALUMINUM CASE UNIT

PART NUMBER	L/B	W	L	H	J	K	S	D	h	A	G	B	M	BASIC LOAD RATING(lbf)		WEIGHT (gf)
								±0.0012	±0.0012					DYNAMIC (C) ^{★2}	STATIC (Co)	
SCB04UU	LMBS04UU	1.63	1.19	0.81	1.312	0.750	0.16	0.8125	0.4370	0.19	0.75	1.00	0.80	60	49	0.089
SCB06UU	LMBS06UU	1.75	1.31	0.94	1.437	0.875	0.16	0.8750	0.5000	0.19	0.88	1.13	0.88	75	66	0.185
SCB08UU	LMBS08UU	2.00	1.69	1.25	1.688	1.000	0.16	1.0000	0.6870	0.25	1.13	1.38	1.10	195	190	0.240
SCB10UU	LMBS10UU	2.50	1.94	1.63	2.125	1.125	0.19	1.2500	0.8750	0.28	1.44	1.75	1.23	365	340	0.455
SCB12UU	LMBS12UU	2.75	2.06	1.75	2.375	1.250	0.19	1.3750	0.9370	0.31	1.56	1.88	1.35	505	430	0.550
SCB16UU	LMBS16UU	3.25	2.81	2.19	2.875	1.750	0.22	1.6250	1.1870	0.38	1.94	2.38	1.84	895	780	1.180
SCB20UU	LMBS20UU	4.00	3.63	2.81	3.500	2.000	0.22	2.0000	1.5000	0.44	2.50	3.00	2.31	1,320	1,270	2.350
SCB24UU	LMBS24UU	4.75	4.00	3.25	4.125	2.500	0.28	2.3750	1.7500	0.50	2.88	3.50	2.62	1,850	1,540	3.440
SCB32UU	LMBS32UU	6.00	5.00	4.06	5.250	3.250	0.41	3.0000	2.1250	0.63	3.63	4.50	3.35	2,735	2,580	6.810

★1 Dynamic load rating is based on the nominal life of 50km

★2 Main unit : inch

★3 1 lbf = 0.453kgf

SCB_OP OPEN ALUMINUM CASE UNIT

● Drawing

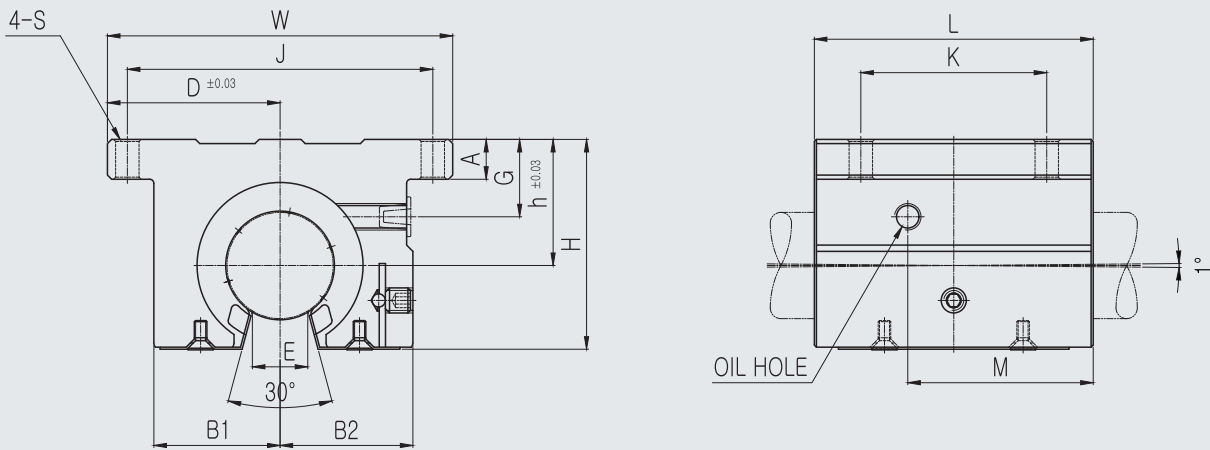

● Part Number Notation

SCB 20 UU OP - N S



● Aluminum Case Unit
Self-Aligning Linear Bushing(inch type)

● Nominal Shaft Diameter

● Seal

Blank	No Seal
UU	Both Side Seal
U	One Side Seal

● Open type Linear Bushing

● Corrosion resistance type

Blank	Stainless steel
N	Electroless nicked plating

● Ball type (material)

Blank	Standard(High Carbon Chromium Bearing Steel Ball)
S	Stainless steel ball

SCB_OP OPEN ALUMINUM CASE UNIT

PART NUMBER	L/B	W	H	L	J	K	S	D	h	A	B1	B2	M	G	E	BASIC LOAD RATING(lbf)		WEIGHT (gf)
								±0.0012	±0.0012							DYNAMIC (C) ^{*2}	STATIC (Co)	
SCB08UUOP	LMBS08UUOP	2.00	1.100	1.50	1.688	1.000	0.16	1.000	0.687	0.25	0.69	0.75	0.99	0.44	0.27	195	190	0.185
SCB10UUOP	LMBS10UUOP	2.50	1.405	1.75	2.125	1.125	0.19	1.250	0.875	0.28	0.88	0.94	1.08	0.47	0.33	480	340	0.361
SCB12UUOP	LMBS12UUOP	2.75	1.535	1.88	2.375	1.250	0.19	1.375	0.937	0.31	0.94	1.00	1.15	0.51	0.39	560	430	0.450
SCB16UUOP	LMBS16UUOP	3.25	1.975	2.62	2.875	1.750	0.22	1.625	1.187	0.38	1.19	1.25	1.75	0.73	0.52	1,010	780	1.005
SCB20UUOP	LMBS20UUOP	4.00	2.485	3.38	3.500	2.000	0.22	2.000	1.500	0.44	1.50	1.63	2.18	0.80	0.58	1,510	1,270	1.975
SCB24UUOP	LMBS24UUOP	4.75	2.910	3.73	4.125	2.500	0.28	2.375	1.750	0.50	1.75	1.87	2.49	0.91	0.70	2,100	1,540	2.945
SLB32UUOP	LMBS32UUOP	6.00	3.660	4.75	5.250	3.250	0.41	3.000	2.125	0.63	2.25	2.44	3.16	1.10	0.96	3,050	2,580	5.830

★1 Dynamic load rating is based on the nominal life of 50km

★2 Main unit : inch

★3 1 lbf = 0.453kgf

SLB ALUMINUM CASE UNIT

● Drawing

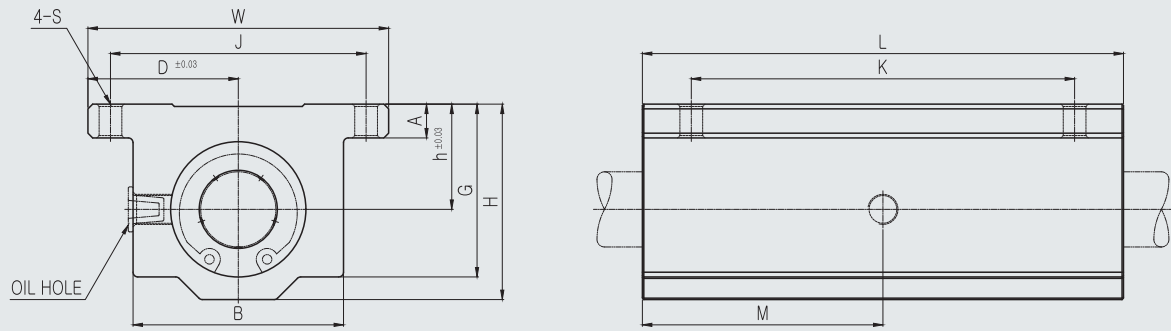

● Part Number Notation

SLB 20 UU - N S



● Aluminum Case Unit
Self-Aligning Linear Bushing(inch type)

● Nominal Shaft Diameter

● Seal

Blank	No Seal
UU	Both Side Seal
U	One Side Seal

● Corrosion resistance type

Blank	Stainless steel
N	Electroless nicked plating

● Ball type (material)

Blank	Standard(High Carbon Chromium Bearing Steel Ball)
S	Stainless steel ball

SLB ALUMINUM CASE UNIT

PART NUMBER	L/B	W	L	H	J	K	S	D	h	A	G	B	M	BASIC LOAD RATING(lbf)		WEIGHT (gf)
								±0.0012	±0.0012					DYNAMIC (C) ^{*2}	STATIC (Co)	
SLB04UU	LMBS04U x2	1.63	2.50	0.81	1.312	2.000	0.16	0.8125	0.4370	0.19	0.75	1.00	1.25	120	98	0.185
SLB06UU	LMBS06U x2	1.75	2.75	0.94	1.437	2.250	0.16	0.8750	0.5000	0.19	0.88	1.13	1.38	150	132	0.240
SLB08UU	LMBS08U x2	2.00	3.50	1.25	1.688	2.500	0.16	1.0000	0.6870	0.25	1.13	1.38	1.75	390	380	0.500
SLB10UU	LMBS10U x2	2.50	4.00	1.63	2.125	3.000	0.19	1.2500	0.8750	0.28	1.44	1.74	2.00	730	680	0.990
SLB12UU	LMBS12U x2	2.75	4.50	1.75	2.375	3.500	0.19	1.3750	0.9370	0.31	1.56	1.88	2.25	1,010	860	1.180
SLB16UU	LMBS16U x2	3.25	6.00	2.19	2.875	4.500	0.22	1.6250	1.1870	0.38	1.94	2.38	3.00	1,790	1,560	2.385
SLB20UU	LMBS20U x2	4.00	7.50	2.81	3.500	5.500	0.22	2.0000	1.5000	0.44	2.50	3.00	3.75	2,640	2,540	4.970
SLB24UU	LMBS24U x2	4.75	9.00	3.25	4.125	6.500	0.28	2.3750	1.7500	0.50	2.88	3.50	4.50	3,700	3,080	7.775

★1 Dynamic load rating is based on the nominal life of 50km

★2 Main unit : inch

★3 1 lbf = 0.453kgf

SLB_OP OPEN ALUMINUM CASE UNIT

● Drawing

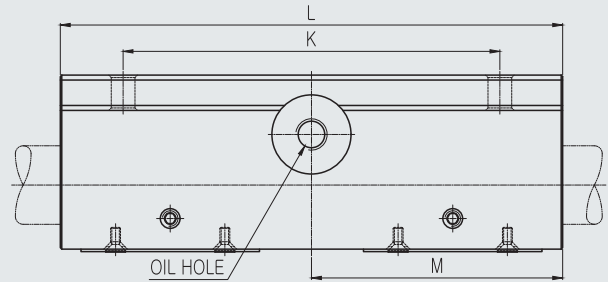
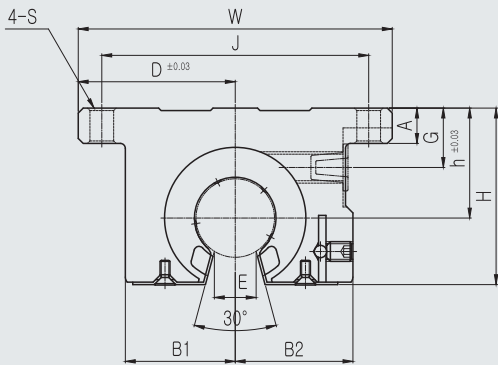

● Part Number Notation

SLB 20 UU OP - N S



● Aluminum Case Unit
Self-Aligning Linear Bushing(inch type)

● Nominal Shaft Diameter

● Seal

Blank	No Seal
UU	Both Side Seal
U	One Side Seal

● Open type Linear Bushing

● Corrosion resistance type

Blank	Stainless steel
N	Electroless nicked plating

● Ball type (material)

Blank	Standard(High Carbon Chromium Bearing Steel Ball)
S	Stainless steel ball

SLB_OP OPEN ALUMINUM CASE UNIT

PART NUMBER	L/B	W	H	L	J	K	S	D	h	A	B1	B2	M	G	E	BASIC LOAD RATING(lbf)		WEIGHT (gf)
								±0.0012	±0.0012							DYNAMIC (C) ^{*2}	STATIC (Co)	
SLB08UUOP	LMBS08UOP x2	2.00	1.100	1.50	1.688	1.000	0.16	1.000	0.687	0.25	0.69	0.75	1.75	0.44	0.27	390	380	0.390
SLB10UUOP	LMBS10UOP x2	2.50	1.405	1.75	2.125	1.125	0.19	1.250	0.875	0.28	0.88	0.94	2.00	0.47	0.33	960	680	0.790
SLB12UUOP	LMBS12UOP x2	2.75	1.535	1.88	2.375	1.250	0.19	1.375	0.937	0.31	0.94	1.00	2.25	0.51	0.39	1,120	860	0.990
SLB16UUOP	LMBS16UOP x2	3.25	1.975	2.62	2.875	1.750	0.22	1.625	1.187	0.38	1.19	1.25	3.00	0.73	0.52	2,020	1,560	1.985
SLB20UUOP	LMBS20UOP x2	4.00	2.485	3.38	3.500	2.000	0.22	2.000	1.500	0.44	1.50	1.63	3.75	0.80	0.58	3,020	2,540	4.190
SLB24UUOP	LMBS24UOP x2	4.75	2.910	3.73	4.125	2.500	0.28	2.375	1.750	0.50	1.75	1.87	4.50	0.91	0.70	4,200	3,080	6.680

★1 Dynamic load rating is based on the nominal life of 50km

★2 Main unit : inch

★3 1 lbf = 0.453kgf

177

SUS SERIES ASIAN STANDARD LINEAR BUSHING(LM-SUS)

LM CLOSED LINEAR BUSHING-SUS SERIES

● Drawing

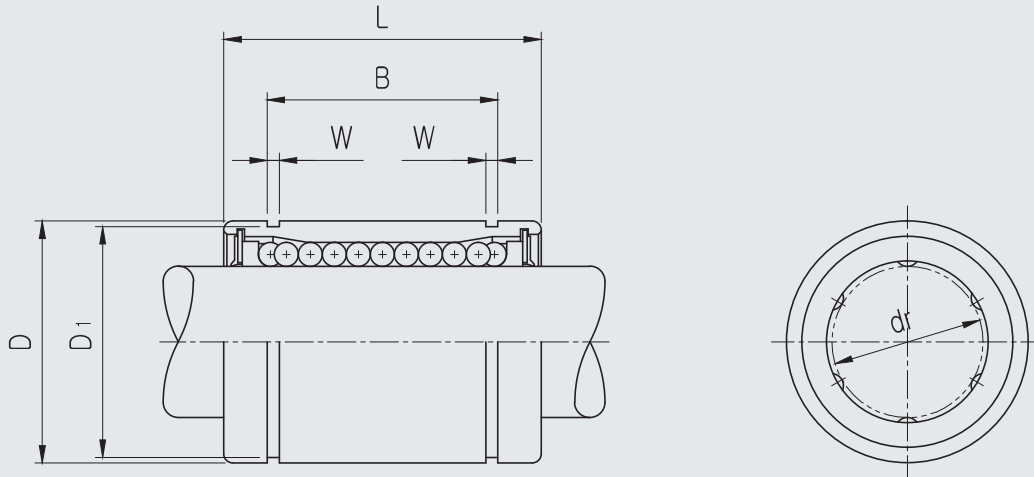

● Part Number Notation

LM 20 UU - SUS A



- SAMICK Linear Bushing
- Nominal Shaft Diameter
- Seal

Blank	No Seal
UU	Both Side Seal
U	One Side Seal

- Outer-sleeves : Stainless Steel
Ball type : Stainless Steel
- Retainer (material)

Blank	Resin Retainer(Standard)
A	Steel Retainer(High temperature) ^{★1}

★1 LM05, LM08S available with resin retainer only

LM CLOSED LINEAR BUSHING-SUS SERIES

PART NUMBER		WORKING BORE DIAMETER		D		L		B		W	D ₁	BASIC LOAD RATING(N) ^{*4}		NO. OF BALL ROW	WEIGHT (gf) ^{*2}
Resin	Steel ^{*5}	dr. (mm)	Tolerance (mm)	mm	Tolerance (mm)	mm	Tolerance (mm)	mm	Tolerance (mm)			DYNAMIC (C) ^{*1}	STATIC (Co)		
LM05UU-SUS		5	0 -0.008	10	0 -0.008	15	0 -0.12	10.2		1.1	9.6	167	206	4	4
LM06UU-SUS	LM06-SUSA	6	0 -0.009	12	0 -0.011	19	0 -0.2	13.5	0 -0.2	1.1	11.5	200	260	4	8
LM08SUU-SUS		8		15		17		11.5		1.1	14.3	170	220	4	11
LM08UU-SUS	LM08-SUSA	8		15		24		17.5		1.1	14.3	260	400	4	16
LM10UU-SUS	LM10-SUSA	10		19		29		22.0		1.3	18	370	540	4	30
LM12UU-SUS	LM12-SUSA	12	0 -0.010	21	0 -0.013	30	0 -0.3	23.0	0 -0.3	1.3	20	410	590	4	31.5
LM13UU-SUS	LM13-SUSA	13		23		32		23.0		1.3	22	500	770	4	43
LM16UU-SUS	LM16-SUSA	16		28		37		26.5		1.6	27	770	1,170	5	69
LM20UU-SUS	LM20-SUSA	20		32		42		30.5		1.6	30.5	860	1,370	5	87
LM25UU-SUS	LM25-SUSA	25	0 -0.010	40	0 -0.016	59	0 -0.3	41.0	0 -0.3	1.85	38	980	1,560	6	220
LM30UU-SUS	LM30-SUSA	30		45		64		44.5		1.85	43	1,560	2,740	6	250

★1 Dynamic load rating is based on the nominal life of 50km

★2 Based on the weight of resin retainer

★3 Main unit : mm

★4 1N ≒ 0.102kgf

★5 LM06 to LM30 applicable with steel retainer only (LM08S applicable with resin retainer only)

LM_L LONG LINEAR BUSHING-SUS SERIES

● Drawing

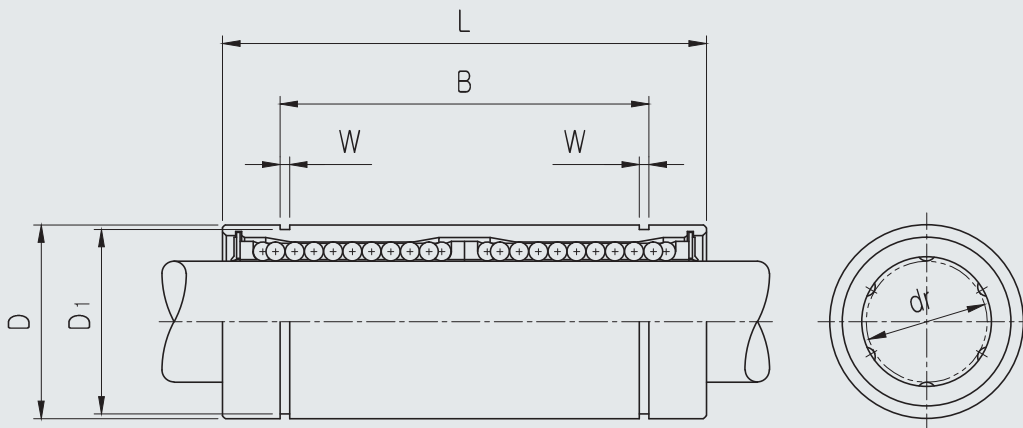

● Part Number Notation

LM 20 L UU - SUS A

- SAMICK Linear Bushing
- Nominal Shaft Diameter
- Linear Bushing Long Type (for high load)
- Seal

Blank	No Seal
UU	Both Side Seal
U	One Side Seal

- Outer-sleeves : Stainless Steel
- BALL : Stainless Steel
- Retainer (material)

Blank	Resin Retainer(Standard)
A	Steel Retainer(High temperature)



LM_L LONG LINEAR BUSHING-SUS SERIES

PART NUMBER		WORKING BORE DIAMETER		D		L		B		W	D ₁	BASIC LOAD RATING(N) ^{*4}		NO. OF BALL ROW	WEIGHT (gf) ^{*2}
Resin	Steel	dr. (mm)	Tolerance (mm)	mm	Tolerance (mm)	mm	Tolerance (mm)	mm	Tolerance (mm)			DYNAMIC (C) ^{*1}	STATIC (Co)		
LM06LUU-SUS	LM06L-SUSA	6	0 -0.010	12	0 -0.013	35	0 -0.3	27	0 -0.3	1.1	11.5	320	520	4	16
LM08LUU-SUS	LM08L-SUSA	8		15		45		35		1.1	14.3	430	780	4	31
LM10LUU-SUS	LM10L-SUSA	10		19	55	44		1.3		18	580	1,100	4	62	
LM12LUU-SUS	LM12L-SUSA	12		21	57	46		1.3		20	650	1,200	4	80	
LM13LUU-SUS	LM13L-SUSA	13		23	61	46		1.3		22	810	1,570	4	90	
LM16LUU-SUS	LM16L-SUSA	16		28	70	53		1.6		27	1,230	2,350	5	145	
LM20LUU-SUS	LM20L-SUSA	20		32	80	61		1.6		30.5	1,400	2,750	5	180	
LM25LUU-SUS	LM25L-SUSA	25		0 -0.012	40	0 -0.019		112		0 -0.4	82	0 -0.4	1.85	38	1,560
LM30LUU-SUS	LM30L-SUSA	30	45		123		89	1.85	43		2,490		5,490	6	580

★1 Dynamic load rating is based on the nominal life of 50km

★2 Based on the weight of resin retainer

★3 Main unit : mm

★4 1N ≒ 0.102kgf

LM_AJ ADJUSTABLE LINEAR BUSHING-SUS SERIES

● Drawing

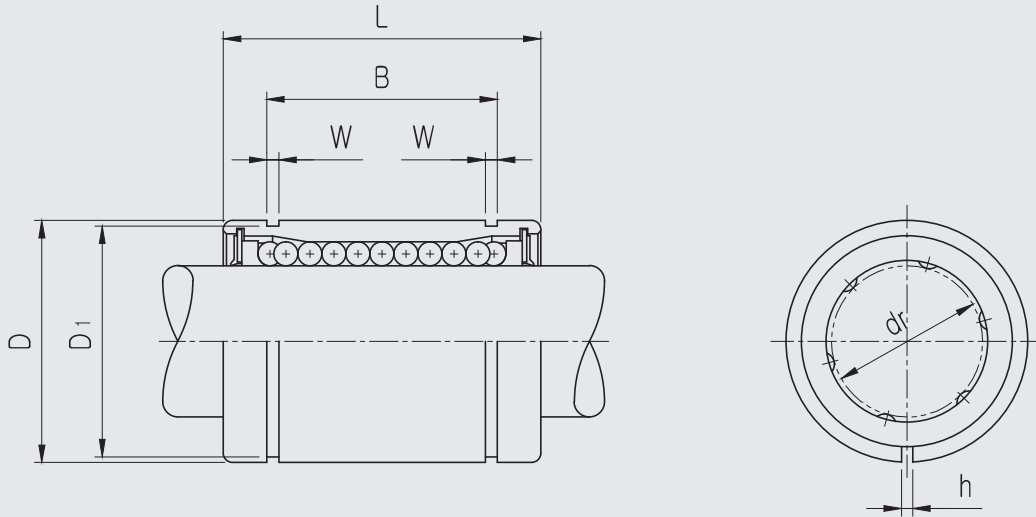

● Part Number Notation

LM 20 UU AJ - SUS A



- SAMICK Linear Bushing
- Nominal Shaft Diameter
- Seal

Blank	No Seal
UU	Both Side Seal
U	One Side Seal

- Linear Bushing Adjustable type
- Outer-sleeves : Stainless Steel
- BALL : Stainless Steel
- Retainer (material)

Blank	Resin Retainer(Standard)
A	Steel Retainer(High temperature) ^{★1}

★1 LM08SAJ available with resin retainer only

LM_AJ ADJUSTABLE LINEAR BUSHING-SUS SERIES

PART NUMBER		WORKING BORE DIAMETER		D		L		B		W	h	D ₁	BASIC LOAD RATING(N) ^{*4}		NO. OF BALL ROW	WEIGHT (g) ^{*2}
Resin	Steel ^{*6}	dr. (mm)	Tolerance (mm)	mm	Tolerance (mm)	mm	Tolerance (mm)	mm	Tolerance (mm)				DYNAMIC (C) ^{*1}	STATIC (Co)		
LM06UUAJ-SUS	LM06AJ-SUSA	6		12	0 -0.011	19	0 -0.2	13.5	0 -0.2	1.1	1	11.5	200	260	4	8
LM08SUUAJ-SUS		8		15		17		11.5		1.1	1	14.3	170	220	4	11
LM08UUAJ-SUS	LM08AJ-SUSA	8		15		24		17.5		1.1	1	14.3	260	400	4	16
LM10UUAJ-SUS	LM10AJ-SUSA	10	0 -0.009	19	0 -0.013	29	0 -0.2	22.0	0 -0.2	1.3	1	18	370	540	4	30
LM12UUAJ-SUS	LM12AJ-SUSA	12		21		30		23.0		1.3	1.5	20	410	590	4	31.5
LM13UUAJ-SUS	LM13AJ-SUSA	13		23		32		23.0		1.3	1.5	22	500	770	4	43
LM16UUAJ-SUS	LM16AJ-SUSA	16		28		37		26.5		1.6	1.5	27	770	1,170	5	69
LM20UUAJ-SUS	LM20AJ-SUSA	20		32		42		30.5		1.6	1.5	30.5	860	1,370	5	87
LM25UUAJ-SUS	LM25AJ-SUSA	25	0 -0.010	40	0 -0.016	59	0 -0.3	41.0	0 -0.3	1.85	2	38	980	1,560	6	220
LM30UUAJ-SUS	LM30AJ-SUSA	30		45		64		44.5		1.85	2.5	43	1,560	2,740	6	250

★1 Dynamic load rating is based on the nominal life of 50km

★2 Based on the weight of resin retainer

★3 Main unit : mm

★4 Outer diameter is the obtained value before the slotting process.

★5 1N ≒ 0.102kgf

★6 LM06AJ to LM30AJ applicable with steel retainer only
(LM08SAJ applicable with resin retainer only)

LM_OP OPEN LINEAR BUSHING-SUS SERIES

● Drawing

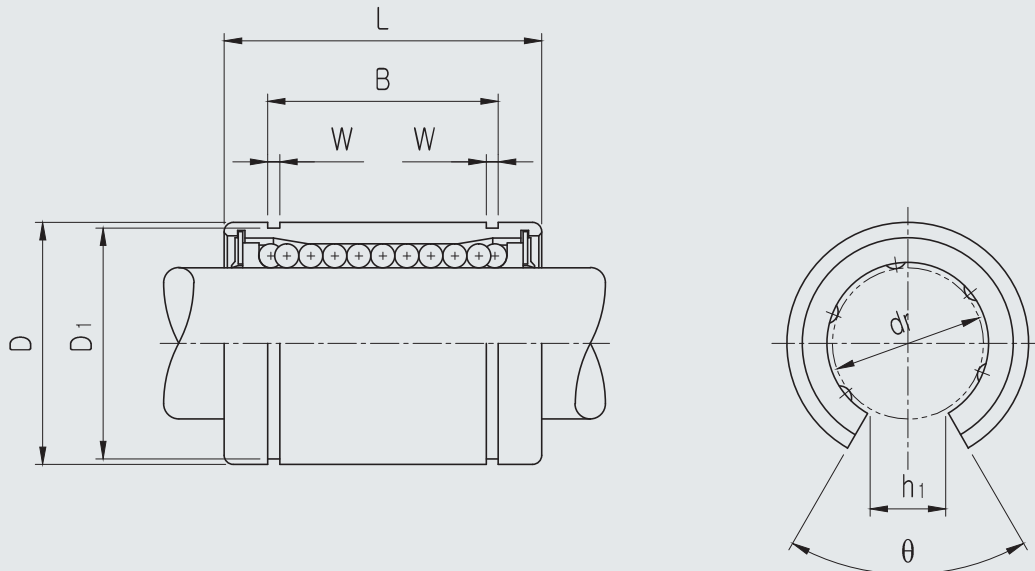

● Part Number Notation

LM 20 UU OP - SUS

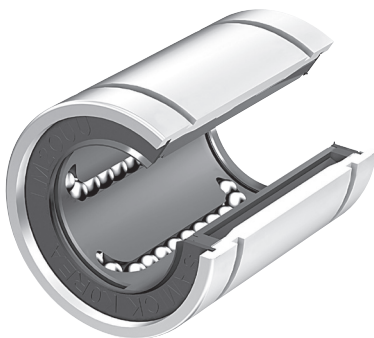
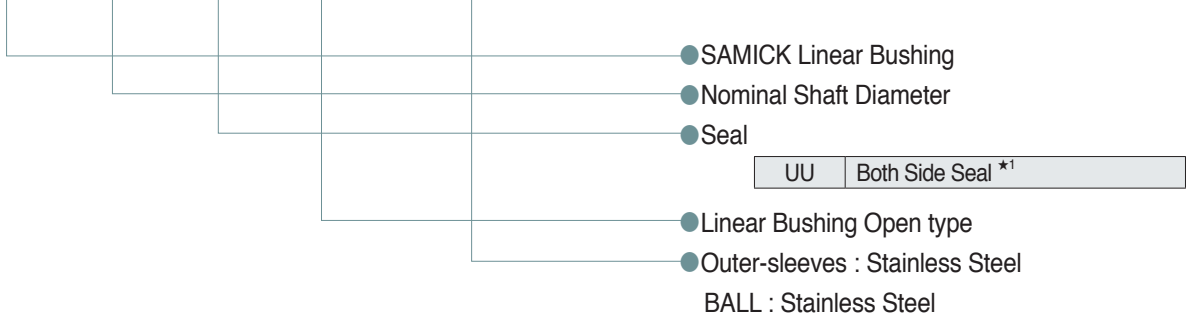

* ★1 UU type only available.
 No seal type & One side seal type not available.
 ★ Resin retainer only applicable

LM_OP OPEN LINEAR BUSHING-SUS SERIES

PART NUMBER	WORKING BORE DIAMETER		D ^{★4}		L		B		W	D ₁	θ	BASIC LOAD RATING(N) ^{★5}		NO. OF BALL ROW	WEIGHT (gf) ^{★2}	
	Resin	dr. (mm)	Tolerance (mm)	mm	Tolerance (mm)	mm	Tolerance (mm)	mm				Tolerance (mm)	DYNAMIC (C) ^{★1}			STATIC (Co)
LM12UUOP-SUS		12		21		30		23.0		1.3	8	80	410	590	3	31.5
LM13UUOP-SUS		13	0 -0.009	23	0 -0.013	32	0 -0.2	23.0	0 -0.2	1.3	9	80	500	770	3	43
LM16UUOP-SUS		16		28		37		26.5		1.6	11	80	770	1,170	4	69
LM20UUOP-SUS		20		32		42		30.5		1.6	11	60	860	1,370	4	87
LM25UUOP-SUS		25	0 -0.010	40	0 -0.016	59	0 -0.3	41.0	0 -0.3	1.85	12	50	980	1,560	5	220
LM30UUOP-SUS		30		45		64		44.5		1.85	15	50	1,560	2,740	5	250

- ★1 Dynamic load rating is based on the nominal life of 50km
- ★2 Based on the weight of resin retainer
- ★3 Main unit : mm
- ★4 Outer diameter is the obtained value before the slotting process.
- ★5 1N ≒ 0.102kgf

LMF FLANGED LINEAR BUSHING-SUS SERIES

● Drawing

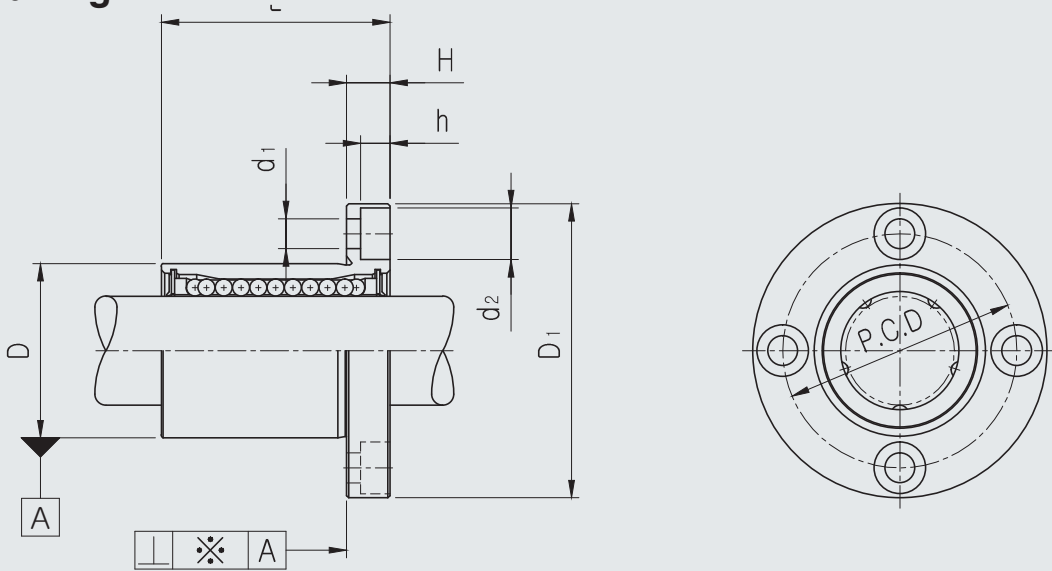

● Part Number Notation

LMF 20 UU - SUS A

- SAMICK Circular Flanged Linear Bushing
- Nominal Shaft Diameter
- Seal

Blank	No Seal
UU	Both Side Seal
U	One Side Seal

- Outer-sleeves : Stainless Steel
- BALL : Stainless Steel
- Retainer (material)

Blank	Resin Retainer(Standard)
A	Steel Retainer(High temperature) ^{★1}



★1 LMF08S available with resin retainer only

LMF FLANGED LINEAR BUSHING-SUS SERIES

PART NUMBER		WORKING BORE DIAMETER		D		L		D ₁		H	PCD	d ₁	d ₂	h	SQUAREDNESS ※(μm)	BASIC LOAD RATING(N) ^{*4}		NO. OF BALL ROW	WEIGHT (gf) ^{*2}
Resin	Steel ^{*5}	dr. (mm)	Tolerance (mm)	mm	Tolerance (mm)	mm	Tolerance (mm)	mm	Tolerance (mm)						※(μm)	DYNAMIC (C) ^{*1}	STATIC (Co)		
LMF06UU-SUS	LMF06-SUSA	6		12		19		28		5	20	3.4	6.5	3.2	12	220	260	4	26.5
LMF08SUU-SUS		8		15	0 -0.011	17		32		5	24	3.4	6.5	3.2	12	170	220	4	34
LMF08UU-SUS	LMF08-SUSA	8		15		24		32		5	24	3.4	6.5	3.2	12	260	400	4	40
LMF10UU-SUS	LMF10-SUSA	10	0 -0.009	19		29		40		6	29	4.5	8.0	4.2	12	370	540	4	78
LMF12UU-SUS	LMF12-SUSA	12		21	0 -0.013	30	±0.2	42		6	32	4.5	8.0	4.2	12	410	590	4	76
LMF13UU-SUS	LMF13-SUSA	13		23		32		43	0 -0.2	6	33	4.5	8.0	4.2	12	500	770	4	94
LMF16UU-SUS	LMF16-SUSA	16		28		37		48		6	38	4.5	8.0	4.2	12	770	1,170	5	134
LMF20UU-SUS	LMF20-SUSA	20		32		42		54		8	43	5.5	9.5	5.2	15	860	1,370	5	180
LMF25UU-SUS	LMF25-SUSA	25	0 -0.010	40	0 -0.016	59		62		8	51	5.5	9.5	5.2	15	980	1,560	6	340
LMF30UU-SUS	LMF30-SUSA	30		45		64	±0.3	74		10	60	6.6	11.0	6.5	15	1,560	2,740	6	460

- ★1 Dynamic load rating is based on the nominal life of 50km
- ★2 Based on the weight of resin retainer
- ★3 Main unit : mm
- ★4 1N ≒ 0.102kgf
- ★5 LMF06 to LMF30 applicable with steel retainer only
(LMF08S applicable with resin retainer only)

LMF_L FLANGED LONG LINEAR BUSHING-SUS SERIES

● Drawing

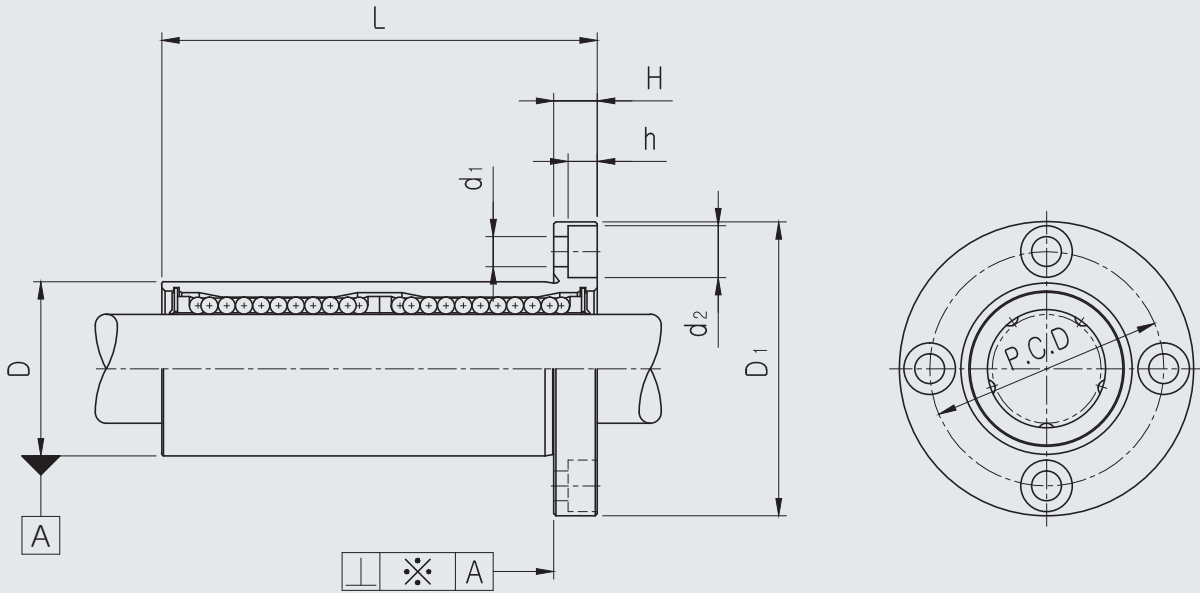

● Part Number Notation

LMF 20 L UU - SUS A

- SAMICK Circular Flanged Linear Bushing
- Nominal Shaft Diameter
- Linear Bushing Long Type (for high load)
- Seal

Blank	No Seal
UU	Both Side Seal
U	One Side Seal

- Outer-sleeves : Stainless Steel
- BALL : Stainless Steel
- Retainer (material)

Blank	Resin Retainer(Standard)
A	Steel Retainer(High temperature)



LMF_L FLANGED LONG LINEAR BUSHING-SUS SERIES

PART NUMBER		WORKING BORE DIAMETER		D		L		D ₁		H	PCD	d ₁	d ₂	h	SQUAR ENESS ※(μm)	BASIC LOAD RATING(N) ^{★4}		NO. OF BALL ROW	WEIGHT (gf) ^{★2}			
Resin	Steel	dr. (mm)	Tolerance (mm)	mm	Tolerance (mm)	mm	Tolerance (mm)	mm	Tolerance (mm)						DYNAMIC (C) ^{★1}	STATIC (Co)						
LMF06LUU-SUS	LMF06L-SUSA	6	0 -0.010	12	0 -0.013	35	±0.3	28	0 -0.2	5	20	3.4	6.5	3.2	15	320	520	4	31			
LMF08LUU-SUS	LMF08L-SUSA	8		15		45		32		5	24	3.4	6.5	3.2	15	430	780	4	53			
LMF10LUU-SUS	LMF10L-SUSA	10		19	55	40		6		29	4.5	8.0	4.2	15	580	1,100	4	105				
LMF12LUU-SUS	LMF12L-SUSA	12		21	57	42		6		32	4.5	8.0	4.2	15	650	1,200	4	100				
LMF13LUU-SUS	LMF13L-SUSA	13		23	61	43		6		33	4.5	8.0	4.2	15	810	1,570	4	130				
LMF16LUU-SUS	LMF16L-SUSA	16		28	70	48		6		38	4.5	8.0	4.2	15	1,230	2,350	5	187				
LMF20LUU-SUS	LMF20L-SUSA	20		32	80	54		8		43	5.5	9.5	5.2	20	1,400	2,750	5	260				
LMF25LUU-SUS	LMF25L-SUSA	25		0 -0.012	40	0 -0.019		112		±0.4	62	0 -0.2	8	51	5.5	9.5	5.2	20	1,560	3,140	6	515
LMF30LUU-SUS	LMF30L-SUSA	30		45	123	74		10			60		6.6	11.0	6.5	20	2,490	5,490	6	655		

★1 Dynamic load rating is based on the nominal life of 50km

★2 Based on the weight of resin retainer

★3 Main unit : mm

★4 1N ≒ 0.102kgf

LMK FLANGED LINEAR BUSHING-SUS SERIES

● Drawing

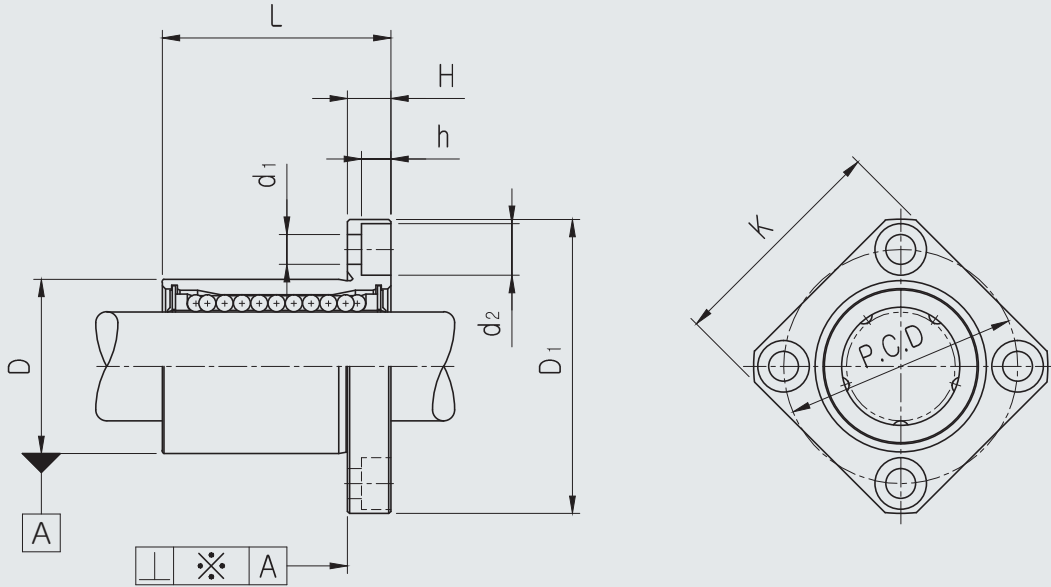

● Part Number Notation

LMK 20 UU - SUS A

- SAMICK Square Flanged Linear Bushing
- Nominal Shaft Diameter
- Seal

Blank	No Seal
UU	Both Side Seal
U	One Side Seal

- Outer-sleeves : Stainless Steel
- BALL : Stainless Steel
- Retainer (material)

Blank	Resin Retainer(Standard)
A	Steel Retainer(High temperature) ^{★1}

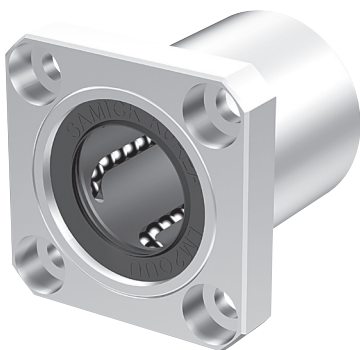

★1 LMK08S available with resin retainer only

LMK FLANGED LINEAR BUSHING-SUS SERIES

PART NUMBER		WORKING BORE DIAMETER		D		L		D ₁		H	PCD	K	d ₁	d ₂	h	SQUAR ENESS ※(μm)	BASIC LOAD RATING(N) ^{*4}		NO. OF BALL ROW	WEIGHT (gf) ^{*2}
Resin	Steel ^{*5}	dr. (mm)	Tolerance (mm)	mm	Tolerance (mm)	mm	Tolerance (mm)	mm	Tolerance (mm)								DYNAMIC (C) ^{*1}	STATIC (Co)		
LMK06UU-SUS	LMK06-SUSA	6		12		19		28		5	20	22	3.4	6.5	3.2	12	200	260	4	26.5
LMK08SUU-SUS		8		15	0 -0.011	17		32		5	24	25	3.4	6.5	3.2	12	170	220	4	34
LMK08UU-SUS	LMK08-SUSA	8		15		24		32		5	24	25	3.4	6.5	3.2	12	260	400	4	40
LMK10UU-SUS	LMK10-SUSA	10	0 -0.009	19		29		40		6	29	30	4.5	8.0	4.2	12	370	540	4	78
LMK12UU-SUS	LMK12-SUSA	12		21	0 -0.013	30	±0.2	42	0 -0.2	6	32	32	4.5	8.0	4.2	12	410	590	4	76
LMK13UU-SUS	LMK13-SUSA	13		23		32		43		6	33	34	4.5	8.0	4.2	12	500	770	4	94
LMK16UU-SUS	LMK16-SUSA	16		28		37		48		6	38	37	4.5	8.0	4.2	12	770	1,170	5	134
LMK20UU-SUS	LMK20-SUSA	20		32		42		54		8	43	42	5.5	9.5	5.2	15	860	1,370	5	180
LMK25UU-SUS	LMK25-SUSA	25	0 -0.010	40	0 -0.016	59	±0.3	62		8	51	50	5.5	9.5	5.2	15	980	1,560	6	340
LMK30UU-SUS	LMK30-SUSA	30		45		64		74		10	60	58	6.6	11.0	6.5	15	1,560	2,740	6	460

- ★1 Dynamic load rating is based on the nominal life of 50km
- ★2 Based on the weight of resin retainer
- ★3 Main unit : mm
- ★4 1N ≒ 0.102kgf
- ★5 LMK06 to LMK30 applicable with steel retainer only
(LMK08S applicable with resin retainer only)

LMK_L FLANGED LONG LINEAR BUSHING-SUS SERIES

● Drawing

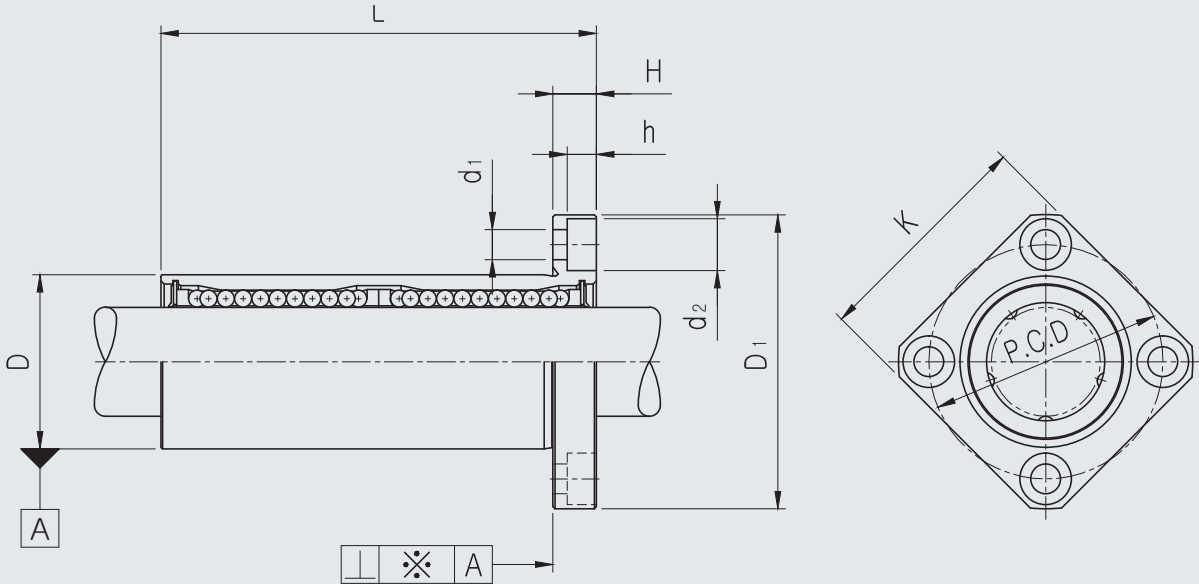

● Part Number Notation

LMK 20 L UU - SUS A

- SAMICK Square Linear Bushing
- Nominal Shaft Diameter
- Linear Bushing Long Type (for high load)
- Seal

Blank	No Seal
UU	Both Side Seal
U	One Side Seal

- Outer-sleeves : Stainless Steel
- BALL : Stainless Steel
- Retainer (material)

Blank	Resin Retainer(Standard)
A	Steel Retainer(High temperature)

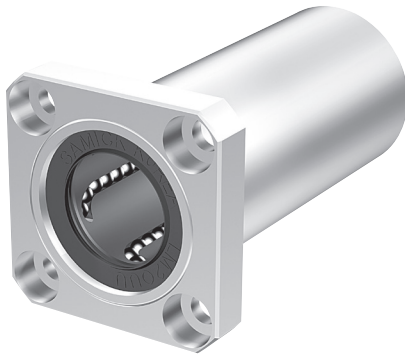

LMK_L FLANGED LONG LINEAR BUSHING-SUS SERIES

PART NUMBER		WORKING BORE DIAMETER		D		L		D ₁		H	PCD	K	d ₁	d ₂	h	SQUARENESSE ※(μm)	BASIC LOAD RATING(N) ^{★4}		NO. OF BALL ROW	WEIGHT (gf) ^{★2}			
Resin	Steel	dr. (mm)	Tolerance (mm)	mm	Tolerance (mm)	mm	Tolerance (mm)	mm	Tolerance (mm)							DYNAMIC (C) ^{★1}	STATIC (Co)						
LMK06LUU-SUS	LMK06L-SUSA	6	0 -0.010	12	0 -0.013	35	±0.3	28	0 -0.2	5	20	22	3.4	6.5	3.2	15	320	520	4	31			
LMK08LUU-SUS	LMK08L-SUSA	8		15		45		32		5	24	25	3.4	6.5	3.2	15	430	780	4	53			
LMK10LUU-SUS	LMK10L-SUSA	10		19	55	40		6		29	30	4.5	8.0	4.2	15	580	1,100	4	105				
LMK12LUU-SUS	LMK12L-SUSA	12		21	57	42		6		32	32	4.5	8.0	4.2	15	650	1,200	4	100				
LMK13LUU-SUS	LMK13L-SUSA	13		23	61	43		6		33	34	4.5	8.0	4.2	15	810	1,570	4	130				
LMK16LUU-SUS	LMK16L-SUSA	16		28	70	48		6		38	37	4.5	8.0	4.2	15	1,230	2,350	5	187				
LMK20LUU-SUS	LMK20L-SUSA	20		32	80	54		8		43	42	5.5	9.5	5.2	20	1,400	2,750	5	260				
LMK25LUU-SUS	LMK25L-SUSA	25		0 -0.012	40	0 -0.019		112		±0.4	62		8	51	50	5.5	9.5	5.2	20	1,560	3,140	6	515
LMK30LUU-SUS	LMK30L-SUSA	30			45			123			74		10	60	58	6.6	11.0	6.5	20	2,490	5,490	6	655

★1 Dynamic load rating is based on the nominal life of 50km

★2 Based on the weight of resin retainer

★3 Main unit : mm

★4 1N ≒ 0.102kgf

LMH FLANGED LINEAR BUSHING-SUS SERIES

● Drawing

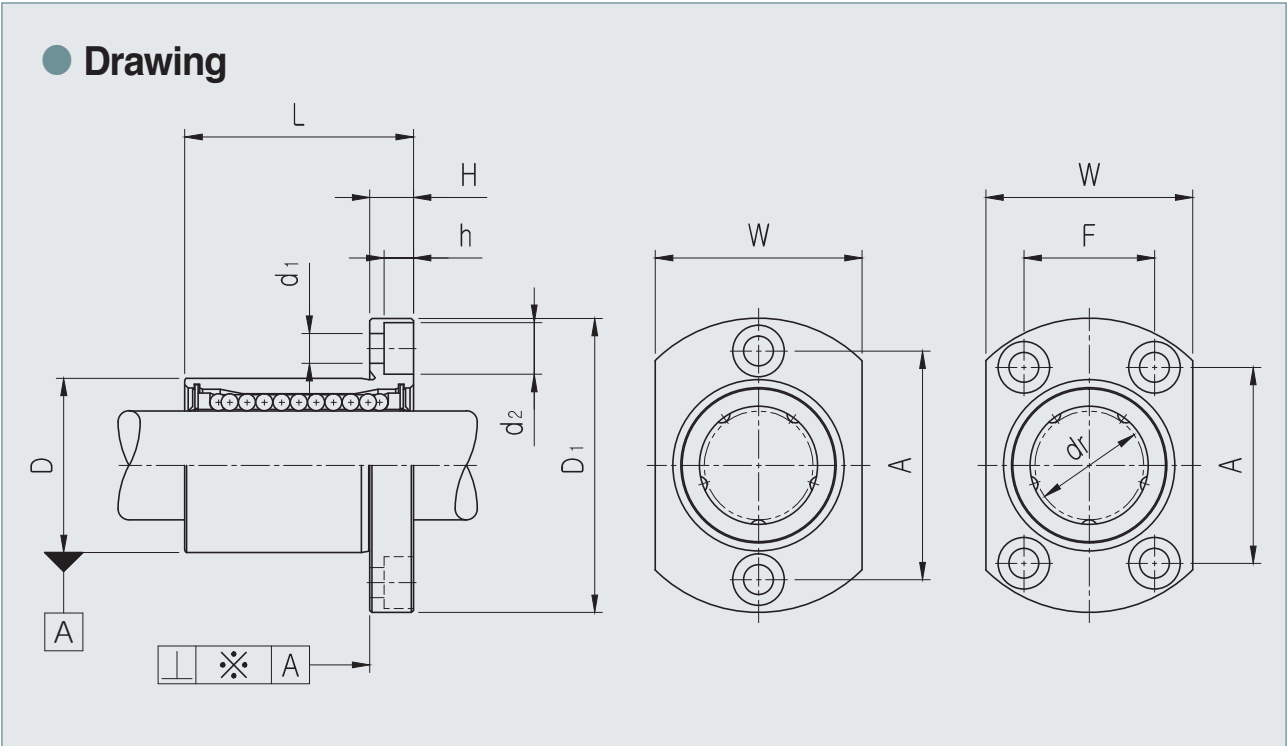

● Part Number Notation

LMH 20 UU - SUS A

- SAMICK Oval Flanged Linear Bushing
- Nominal Shaft Diameter
- Seal

Blank	No Seal
UU	Both Side Seal
U	One Side Seal

- Outer-sleeves : Stainless Steel
- BALL : Stainless Steel
- Retainer (material)

Blank	Resin Retainer(Standard)
A	Steel Retainer(High temperature)

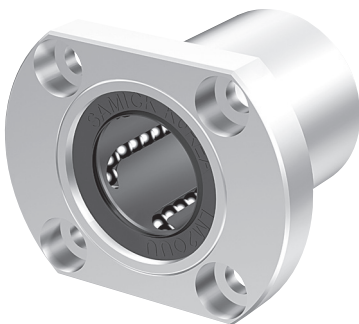

LMH FLANGED LINEAR BUSHING-SUS SERIES

PART NUMBER		WORKING BORE DIAMETER		D		L		D ₁		H	W	A	F	d ₁	d ₂	h	SQUARENESSE ※(μm)	BASIC LOAD RATING(N) ^{*4}		NO. OF BALL ROW	WEIGHT (gf) ^{*2}		
Resin	Steel	dr. (mm)	Tolerance (mm)	mm	Tolerance (mm)	mm	Tolerance (mm)	mm	Tolerance (mm)								DYNAMIC (C) ^{*1}	STATIC (Co)					
LMH06UU-SUS	LMH06-SUSA	6	0 -0.09	12	0	19	±0.2	28	0 -0.2	5	18	20	-	3.4	6.5	3.2	12	200	260	4	26.5		
LMH08UU-SUS	LMH08-SUSA	8		15	-0.011	24		32		5	21	24	-	3.4	6.5	3.2	12	260	400	4	40		
LMH10UU-SUS	LMH10-SUSA	10		19	29	40		6		25	29	-	4.5	8.0	4.2	12	370	540	4	78			
LMH12UU-SUS	LMH12-SUSA	12		21	0	30		42		6	27	32	-	4.5	8.0	4.2	12	410	590	4	76		
LMH13UU-SUS	LMH13-SUSA	13		23	-0.013	32		43		6	29	33	-	4.5	8.0	4.2	12	500	770	4	94		
LMH16UU-SUS	LMH16-SUSA	16		28	37	48		6		34	31	22	4.5	8.0	4.2	12	770	1,170	5	134			
LMH20UU-SUS	LMH20-SUSA	20		32	42	54		8		38	36	24	5.5	9.5	5.2	15	860	1,370	5	180			
LMH25UU-SUS	LMH25-SUSA	25		0	0	40		-0.016		59	62	8	46	40	32	5.5	9.5	5.2	15	980	1,560	6	340
LMH30UU-SUS	LMH30-SUSA	30		-0.010	45	64		±0.3		74	10	51	49	35	6.6	11.0	6.5	15	1,560	2,740	6	450	

★1 Dynamic load rating is based on the nominal life of 50km

★2 Based on the weight of resin retainer

★3 Main unit : mm

★4 1N ≒ 0.102kgf

LMH_L FLANGED LONG LINEAR BUSHING-SUS SERIES

● Drawing

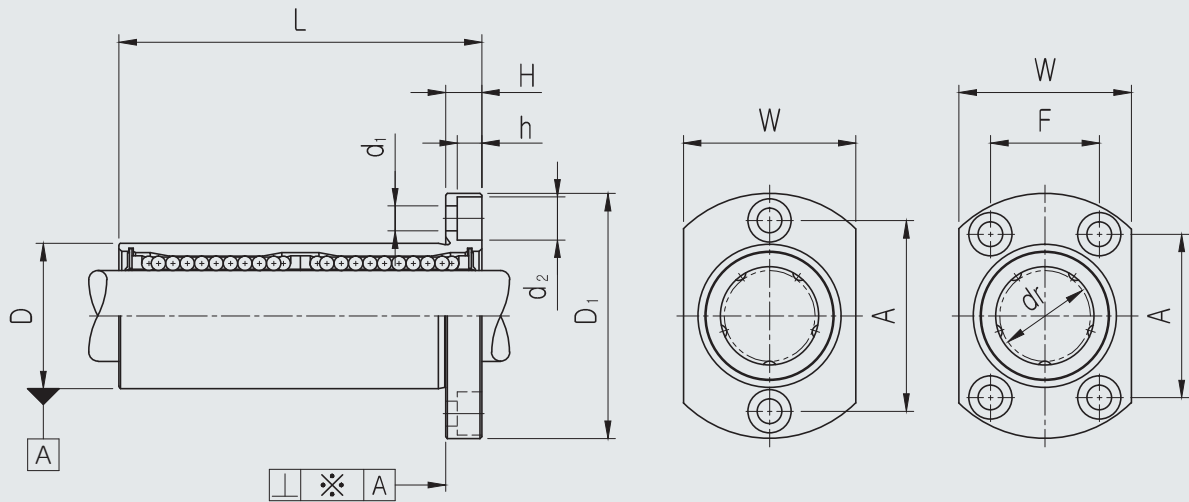

● Part Number Notation

LMH 20 L UU - SUS A

- SAMICK Oval Flanged Linear Bushing
- Nominal Shaft Diameter
- Linear Bushing Long Type (for high load)
- Seal

Blank	No Seal
UU	Both Side Seal
U	One Side Seal

- Outer-sleeves : Stainless Steel
- BALL : Stainless Steel
- Retainer (material)

Blank	Resin Retainer(Standard)
A	Steel Retainer(High temperature)



LMH_L FLANGED LONG LINEAR BUSHING-SUS SERIES

PART NUMBER		WORKING BORE DIAMETER		D		L		D ₁		H	W	A	F	d ₁	d ₂	h	SQUAR ENESS ※(μm)	BASIC LOAD RATING(N) ^{★4}		NO. OF BALL ROW	WEIGHT (gf) ^{★2}
Resin	Steel	dr. (mm)	Tolerance (mm)	mm	Tolerance (mm)	mm	Tolerance (mm)	mm	Tolerance (mm)								DYNAMIC (C) ^{★1}	STATIC (Co)			
LMH06LUU-SUS	LMH06L-SUSA	6	0 -0.010	12	0	35	±0.3	28	0 -0.2	5	18	20	-	3.4	6.5	3.2	15	320	520	4	31
LMH08LUU-SUS	LMH08L-SUSA	8		15	-0.013	45		32		5	21	24	-	3.4	6.5	3.2	15	430	780	4	53
LMH10LUU-SUS	LMH10L-SUSA	10		19		55		40		6	25	29	-	4.5	8.0	4.2	15	580	1,100	4	105
LMH12LUU-SUS	LMH12L-SUSA	12		21	0	57		42		6	27	32	-	4.5	8.0	4.2	15	650	1,200	4	100
LMH13LUU-SUS	LMH13L-SUSA	13		23	-0.016	61		43		6	29	33	-	4.5	8.0	4.2	15	810	1,570	4	130
LMH16LUU-SUS	LMH16L-SUSA	16		28		70		48		6	34	31	22	4.5	8.0	4.2	15	1,230	2,350	5	187
LMH20LUU-SUS	LMH20L-SUSA	20		32		80		54		8	38	36	24	5.5	9.5	5.2	20	1,400	2,750	5	260
LMH25LUU-SUS	LMH25L-SUSA	25		40	0	112		62		8	46	40	32	5.5	9.5	5.2	20	1,560	3,140	6	515
LMH30LUU-SUS	LMH30L-SUSA	30		45	-0.012	123		74		10	51	49	35	6.6	11.0	6.5	20	2,490	5,490	6	615

★1 Dynamic load rating is based on the nominal life of 50km

★2 Based on the weight of resin retainer

★3 Main unit : mm

★4 1N ≒ 0.102kgf

LMFP FLANGED LINEAR BUSHING-SUS SERIES

● Drawing

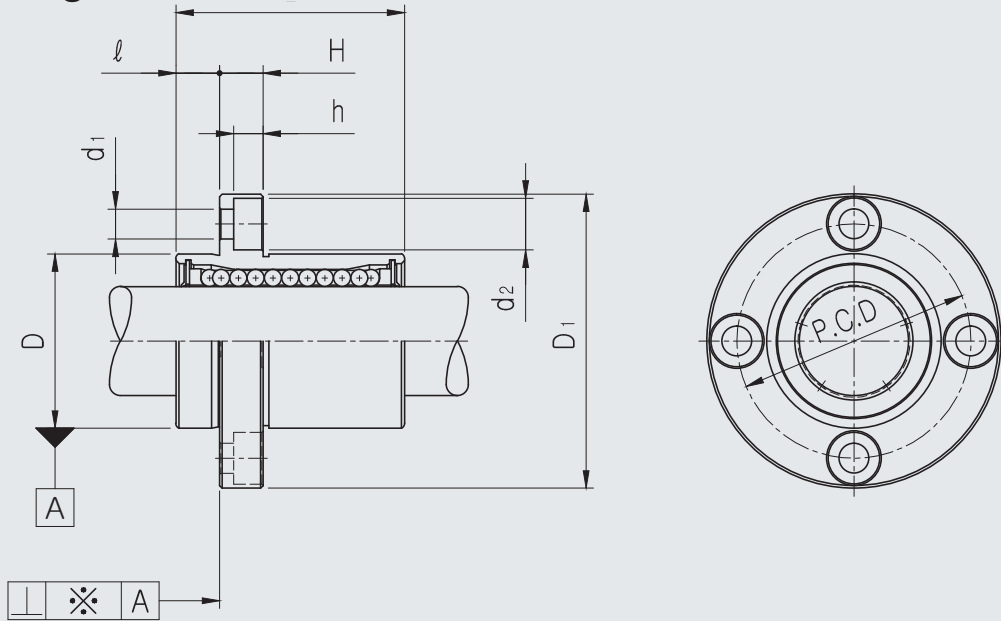

● Part Number Notation

LMFP 20 UU - SUS A

- SAMICK Circular Pilot Flanged Linear Bushing
- Nominal Shaft Diameter
- Seal

Blank	No Seal
UU	Both Side Seal
U	One Side Seal

- Outer-sleeves : Stainless Steel
- BALL : Stainless Steel
- Retainer (material)

Blank	Resin Retainer(Standard)
A	Steel Retainer(High temperature)



LMFP FLANGED LINEAR BUSHING-SUS SERIES

PART NUMBER		WORKING BORE DIAMETER		D		L		D ₁		ℓ	H	PCD	d ₁	d ₂	h	SQUAR ENESS ※(μm)	BASIC LOAD RATING(N) ^{*4}		NO. OF BALL ROW	WEIGHT (gf) ^{*2}	
Resin	Steel	dr. (mm)	Tolerance (mm)	mm	Tolerance (mm)	mm	Tolerance (mm)	mm	Tolerance (mm)								DYNAMIC (C) ^{*1}	STATIC (Co)			
LMFP06UU-SUS	LMFP06-SUSA	6	0 -0.009	12	0 -0.011	19	0 -0.2	28	0 -0.2	5	5	20	3.4	6.5	3.2	12	200	260	4	26.5	
LMFP08UU-SUS	LMFP08-SUSA	8		15		24		32		5	5	24	3.4	6.5	3.2	12	260	400	4	40	
LMFP10UU-SUS	LMFP10-SUSA	10		19	29	40		6		6	29	4.5	8	4.2	12	370	540	4	76		
LMFP12UU-SUS	LMFP12-SUSA	12		21	30	42		6		6	32	4.5	8	4.2	12	410	590	4	78		
LMFP13UU-SUS	LMFP13-SUSA	13		23	32	43		6		6	33	4.5	8	4.2	12	500	770	4	94		
LMFP16UU-SUS	LMFP16-SUSA	16		28	37	48		6		6	38	4.5	8	4.2	12	770	1,170	5	134		
LMFP20UU-SUS	LMFP20-SUSA	20		32	42	54		8		8	43	5.5	9.5	5.2	15	860	1,370	5	180		
LMFP25UU-SUS	LMFP25-SUSA	25		0 -0.010	0 -0.016	59		0 -0.3		62	8	8	51	5.5	9.5	5.2	15	980	1,560	6	340
LMFP30UU-SUS	LMFP30-SUSA	30		45	64	74				10	10	60	6.6	11	6.5	15	1,560	2,740	6	460	

★1 Dynamic load rating is based on the nominal life of 50km

★2 Based on the weight of resin retainer

★3 Main unit : mm

★4 1N ≒ 0.102kgf

LMFP_L FLANGED LONG LINEAR BUSHING-SUS SERIES

● Drawing

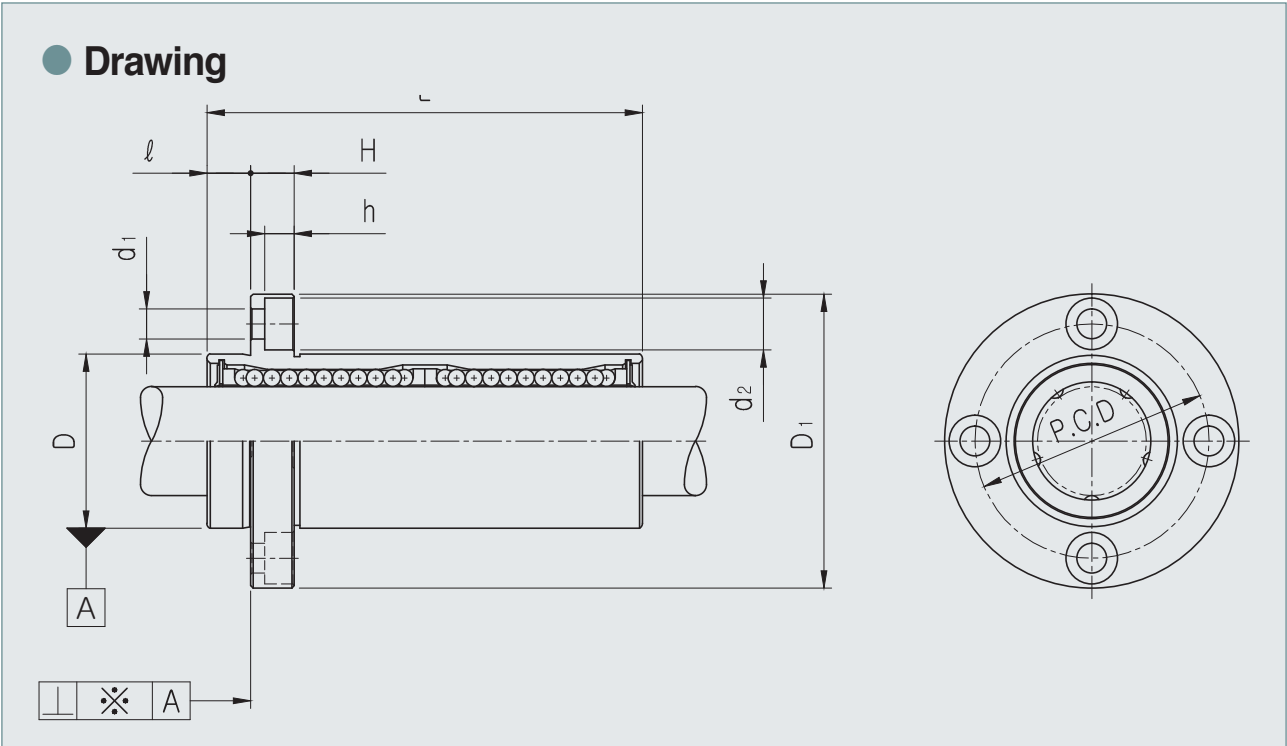

● Part Number Notation

LMFP 20 L UU - SUS A

- SAMICK Circular Flanged Linear Bushing
- Nominal Shaft Diameter
- Linear Bushing Long Type (for high load)
- Seal

Blank	No Seal
UU	Both Side Seal
U	One Side Seal

- Outer-sleeves : Stainless Steel
- BALL : Stainless Steel
- Retainer (material)

Blank	Resin Retainer(Standard)
A	Steel Retainer(High temperature)



LMFP_L FLANGED LONG LINEAR BUSHING-SUS SERIES

PART NUMBER		WORKING BORE DIAMETER		D		L		D ₁		ℓ	H	PCD	d ₁	d ₂	h	SQUAR ENESS ※(μm)	BASIC LOAD RATING(N) ^{★4}		NO. OF BALL ROW	WEIGHT (gf) ^{★2}		
Resin	Steel	dr. (mm)	Tolerance (mm)	mm	Tolerance (mm)	mm	Tolerance (mm)	mm	Tolerance (mm)								DYNAMIC (C) ^{★1}	STATIC (Co)				
LMFP06LUU-SUS	LMFP06L-SUSA	6	0 -0.010	12	0 -0.013	35	0 -0.3	28	0 -0.2	5	5	20	3.4	6.5	3.2	15	320	520	4	31		
LMFP08LUU-SUS	LMFP08L-SUSA	8		15		45		32		5	5	24	3.4	6.5	3.2	15	430	780	4	53		
LMFP10LUU-SUS	LMFP10L-SUSA	10		19	55	40		6		6	29	4.5	8	4.2	15	580	1,100	4	105			
LMFP12LUU-SUS	LMFP12L-SUSA	12		21	0 -0.016	57		42		6	6	32	4.5	8	4.2	15	650	1,200	4	100		
LMFP13LUU-SUS	LMFP13L-SUSA	13		23		61				43	6	6	33	4.5	8	4.2	15	810	1,570	4	130	
LMFP16LUU-SUS	LMFP16L-SUSA	16		28	70	48		6		6	38	4.5	8	4.2	15	1,230	2,350	5	187			
LMFP20LUU-SUS	LMFP20L-SUSA	20		32	80	54		8		8	43	5.5	9.5	5.2	20	1,400	2,750	5	260			
LMFP25LUU-SUS	LMFP25L-SUSA	25		0 -0.012	40	0 -0.019		112		0 -0.4	62	8	8	51	5.5	9.5	5.2	20	1,560	3,140	6	515
LMFP30LUU-SUS	LMFP30L-SUSA	30			45			123			74		10	10	60	6.6	11	6.5	20	2,490	5,490	6

★1 Dynamic load rating is based on the nominal life of 50km

★2 Based on the weight of resin retainer

★3 Main unit : mm

★4 1N ≒ 0.102kgf

LMKP FLANGED LINEAR BUSHING-SUS SERIES

● Drawing

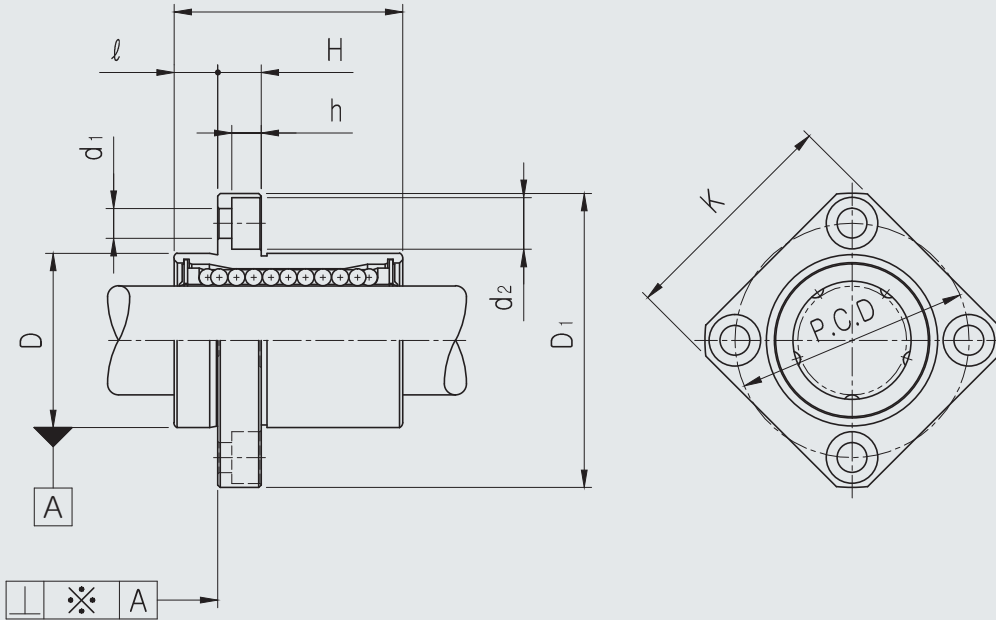

● Part Number Notation

LMKP 20 UU - SUS A

- SAMICK Square Pilot Flanged Linear Bushing
- Nominal Shaft Diameter
- Seal

Blank	No Seal
UU	Both Side Seal
U	One Side Seal

- Outer-sleeves : Stainless Steel
- BALL : Stainless Steel
- Retainer (material)

Blank	Resin Retainer(Standard)
A	Steel Retainer(High temperature)

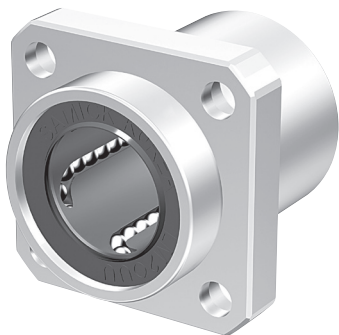

LMKP FLANGED LINEAR BUSHING-SUS SERIES

PART NUMBER		WORKING BORE DIAMETER		D		L		D ₁		ℓ	H	PCD	K	d ₁	d ₂	h	SQUARENESSE ※(μm)	BASIC LOAD RATING(N) ^{★1}		NO. OF BALL ROW	WEIGHT (gf) ^{★2}			
Resin	Steel	dr. (mm)	Tolerance (mm)	mm	Tolerance (mm)	mm	Tolerance (mm)	mm	Tolerance (mm)									DYNAMIC (C) ^{★1}	STATIC (Co)					
LMKP06UU-SUS	LMKP06-SUSA	6	0 -0.009	12	0 -0.011	19	0 -0.2	28	0 -0.2	5	5	20	22	3.4	6.5	3.2	12	200	260	4	26.5			
LMKP08UU-SUS	LMKP08-SUSA	8		15		24		32		5	5	24	25	3.4	6.5	3.2	12	260	400	4	40			
LMKP10UU-SUS	LMKP10-SUSA	10		19	29	40		6		6	29	30	4.5	8	4.2	12	370	540	4	76				
LMKP12UU-SUS	LMKP12-SUSA	12		21	30	42		6		6	32	32	4.5	8	4.2	12	410	590	4	78				
LMKP13UU-SUS	LMKP13-SUSA	13		23	32	43		6		6	33	34	4.5	8	4.2	12	500	770	4	94				
LMKP16UU-SUS	LMKP16-SUSA	16		28	37	48		6		6	38	37	4.5	8	4.2	12	770	1,170	5	134				
LMKP20UU-SUS	LMKP20-SUSA	20		32	42	54		8		8	43	42	5.5	9.5	5.2	15	860	1,370	5	180				
LMKP25UU-SUS	LMKP25-SUSA	25		0 -0.010	40	0 -0.016		59		0 -0.3	62	0 -0.2	8	8	51	50	5.5	9.5	5.2	15	980	1,560	6	340
LMKP30UU-SUS	LMKP30-SUSA	30		45	64	74		10			10		60	58	6.6	11	6.5	15	1,560	2,740	6	460		

★1 Dynamic load rating is based on the nominal life of 50km

★2 Based on the weight of resin retainer

★3 Main unit : mm

★4 1N ≒ 0.102kgf

LMKP_L FLANGED LONG LINEAR BUSHING-SUS SERIES

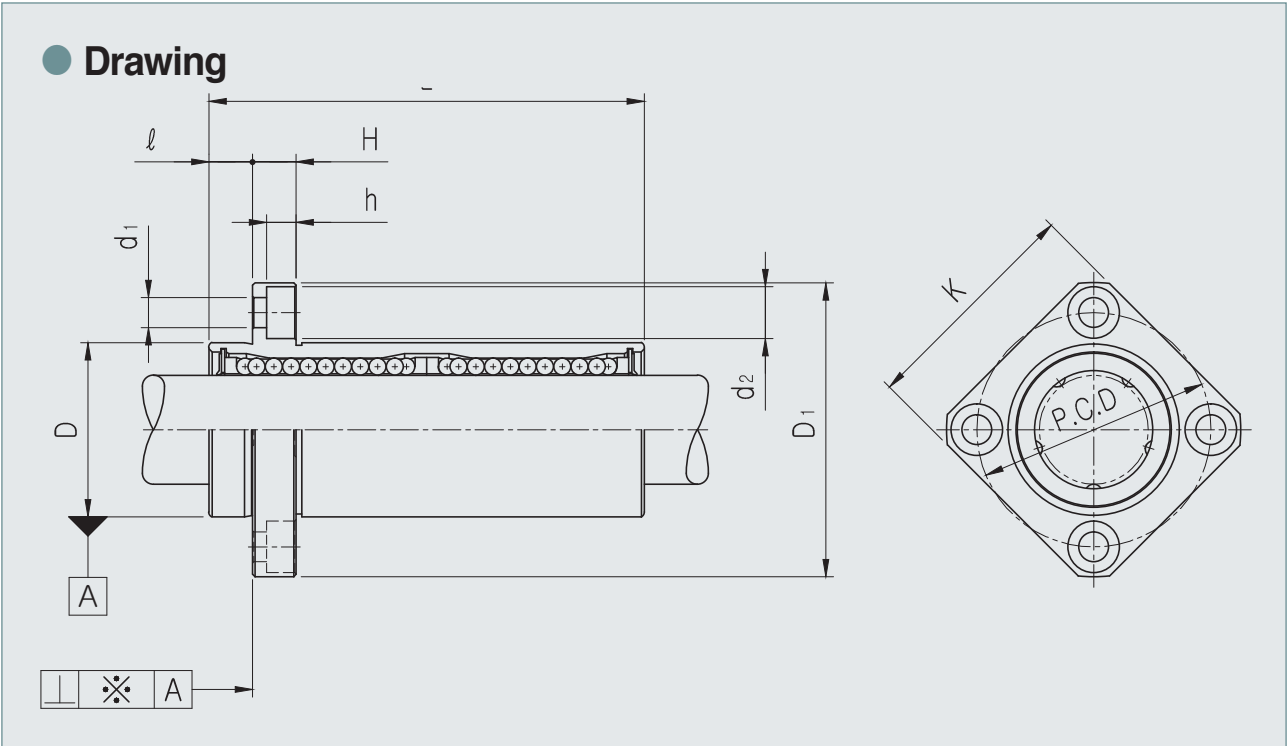

● Part Number Notation

LMKP 20 L UU - SUS A

- SAMICK Square Flanged Linear Bushing
- Nominal Shaft Diameter
- Linear Bushing Long Type (for high load)
- Seal

Blank	No Seal
UU	Both Side Seal
U	One Side Seal

- Outer-sleeves : Stainless Steel
- BALL : Stainless Steel
- Retainer (material)

Blank	Resin Retainer(Standard)
A	Steel Retainer(High temperature)

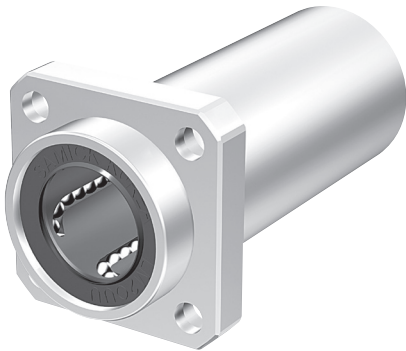

LMKP_L FLANGED LONG LINEAR BUSHING-SUS SERIES

PART NUMBER		WORKING BORE DIAMETER		D		L		D ₁		l	H	PCD	K	d ₁	d ₂	h	SQUAR ENESS ※(μm)	BASIC LOAD RATING(N) ^{★4}		NO. OF BALL ROW	WEIGHT (gf) ^{★2}			
Resin	Steel	dr. (mm)	Tolerance (mm)	mm	Tolerance (mm)	mm	Tolerance (mm)	mm	Tolerance (mm)									DYNAMIC (C) ^{★1}	STATIC (Co)					
LMKP06LUU-SUS	LMKP06L-SUSA	6	0 -0.010	12	0 -0.013	35	0 -0.3	28	0 -0.2	5	5	20	22	3.4	6.5	3.2	15	320	520	4	31			
LMKP08LUU-SUS	LMKP08L-SUSA	8		15		45		32		5	5	24	25	3.4	6.5	3.2	15	430	780	4	53			
LMKP10LUU-SUS	LMKP10L-SUSA	10		19	55	40		6		6	29	30	4.5	8	4.2	15	580	1,100	4	105				
LMKP12LUU-SUS	LMKP12L-SUSA	12		21	57	42		6		6	32	32	4.5	8	4.2	15	650	1,200	4	100				
LMKP13LUU-SUS	LMKP13L-SUSA	13		23	61	43		6		6	33	34	4.5	8	4.2	15	810	1,570	4	130				
LMKP16LUU-SUS	LMKP16L-SUSA	16		28	70	48		6		6	38	37	4.5	8	4.2	15	1,230	2,350	5	187				
LMKP20LUU-SUS	LMKP20L-SUSA	20		32	80	54		8		8	43	42	5.5	9.5	5.2	20	1,400	2,750	5	260				
LMKP25LUU-SUS	LMKP25L-SUSA	25		0 -0.012	40	0 -0.019		112		0 -0.4	62	0 -0.2	8	8	51	50	5.5	9.5	5.2	20	1,560	3,140	6	515
LMKP30LUU-SUS	LMKP30L-SUSA	30		45	123	74		10			10		60	58	6.6	11	6.5	20	2,490	5,490	6	655		

★1 Dynamic load rating is based on the nominal life of 50km

★2 Based on the weight of resin retainer

★3 Main unit : mm

★4 1N ≒ 0.102kgf

LMHP FLANGED LINEAR BUSHING-SUS SERIES

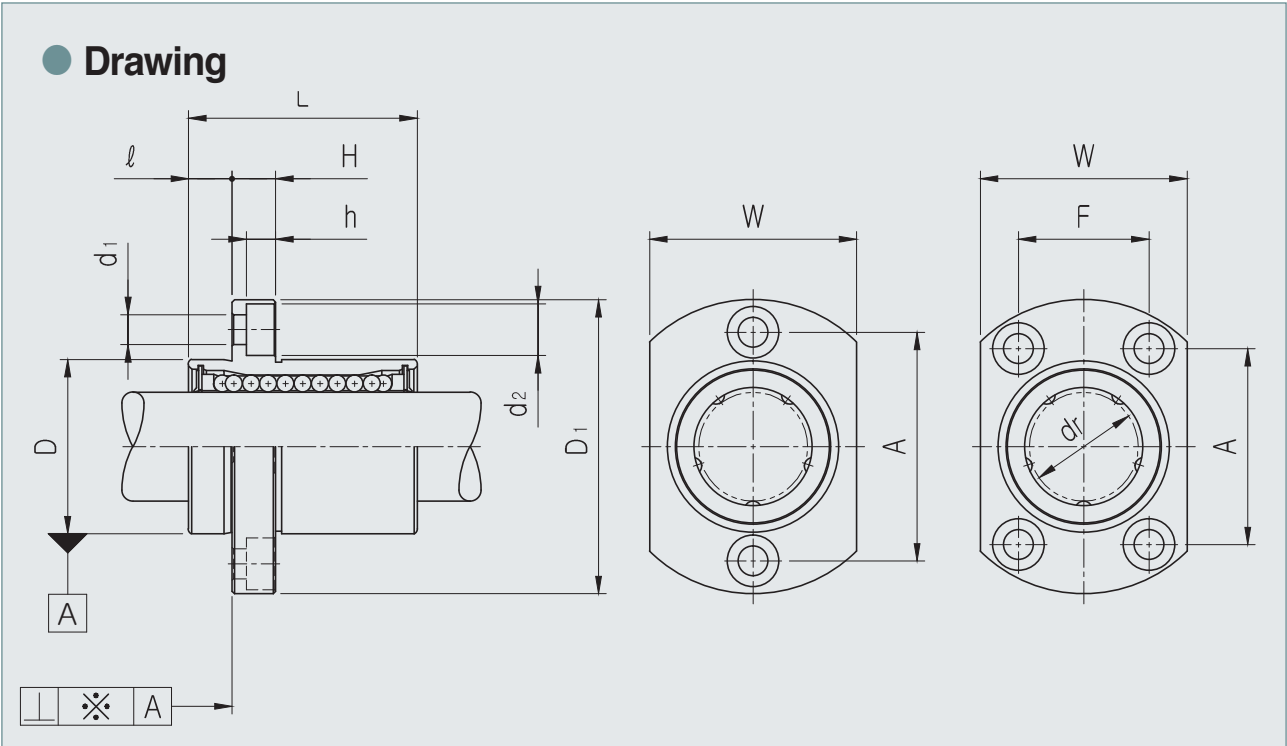

● Part Number Notation

LMHP 20 UU - SUS A

- SAMICK Oval Pilot Flanged Linear Bushing
- Nominal Shaft Diameter
- Seal

Blank	No Seal
UU	Both Side Seal
U	One Side Seal

- Outer-sleeves : Stainless Steel
- BALL : Stainless Steel
- Retainer (material)

Blank	Resin Retainer(Standard)
A	Steel Retainer(High temperature)



LMHP FLANGED LINEAR BUSHING-SUS SERIES

PART NUMBER		WORKING BORE DIAMETER		D		L		D ₁		ℓ	H	W	A	F	d ₁	d ₂	h	SQUAR ENESS ※(μm)	BASIC LOAD RATING(N) ^{★4}		NO. OF BALL ROW	WEIGHT (gf) ^{★2}		
Resin	Steel	dr. (mm)	Tolerance (mm)	mm	Tolerance (mm)	mm	Tolerance (mm)	mm	Tolerance (mm)									DYNAMIC (C) ^{★1}	STATIC (Co)					
LMHP06UU-SUS	LMHP06-SUSA	6	0 -0.009	12	0	19	0 -0.2	28	0 -0.2	5	5	18	20		3.4	6.5	3.2	12	200	260	4	26.5		
LMHP08UU-SUS	LMHP08-SUSA	8		15	-0.011	24		32		5	5	21	24		3.4	6.5	3.2	12	260	400	4	40		
LMHP10UU-SUS	LMHP10-SUSA	10		19		29		40		6	6	25	29		4.5	8	4.2	12	370	540	4	76		
LMHP12UU-SUS	LMHP12-SUSA	12		21	0	30		42		6	6	27	32		4.5	8	4.2	12	410	590	4	78		
LMHP13UU-SUS	LMHP13-SUSA	13		23	-0.013	32		43		6	6	29	33		4.5	8	4.2	12	500	770	4	94		
LMHP16UU-SUS	LMHP16-SUSA	16		28		37		48		6	6	34	31	22	4.5	8	4.2	12	770	1,170	5	134		
LMHP20UU-SUS	LMHP20-SUSA	20		32		42		54		8	8	38	36	24	5.5	9.5	5.2	15	860	1,370	5	180		
LMHP25UU-SUS	LMHP25-SUSA	25		0 -0.010	40	0 -0.016		59		0 -0.3	62	8	8	46	40	32	5.5	9.5	5.2	15	980	1,560	6	340
LMHP30UU-SUS	LMHP30-SUSA	30		45		64		74		10	10	51	49	35	6.6	11	6.5	15	1,560	2,740	6	460		

★1 Dynamic load rating is based on the nominal life of 50km

★2 Based on the weight of resin retainer

★3 Main unit : mm

★4 1N ≒ 0.102kgf

LMHP_L FLANGED LONG LINEAR BUSHING-SUS SERIES

● Drawing

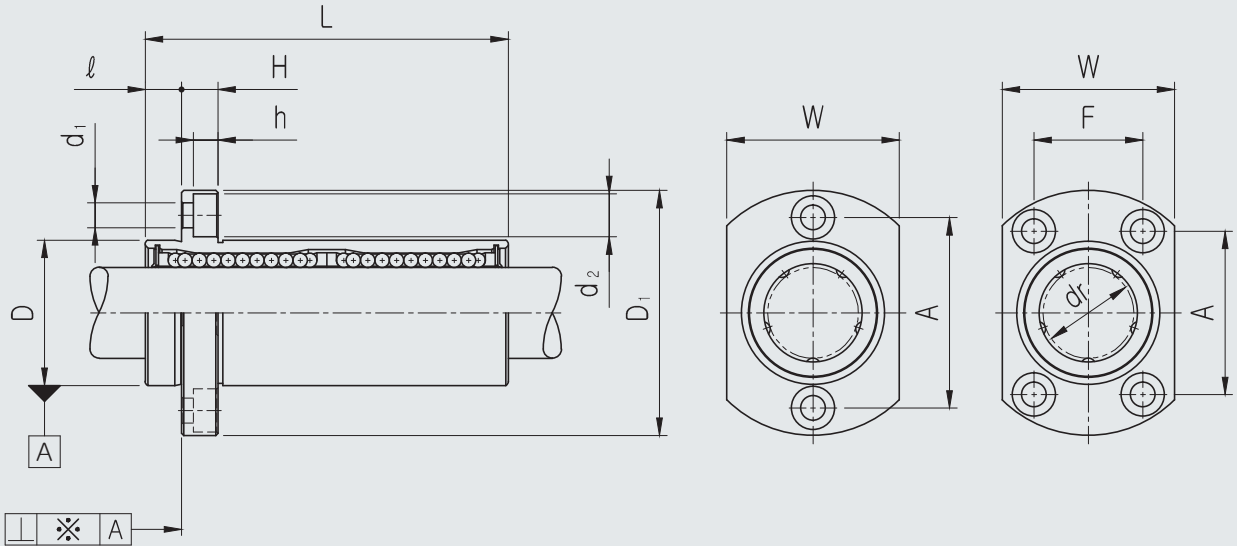

● Part Number Notation

LMHP 20 L UU - SUS A

- SAMICK Circular Middle Flanged Linear Bushing
- Nominal Shaft Diameter
- Linear Bushing Long Type (for high load)
- Seal

Blank	No Seal
UU	Both Side Seal
U	One Side Seal

- Outer-sleeves : Stainless Steel

BALL : Stainless Steel

- Retainer (material)

Blank	Resin Retainer(Standard)
A	Steel Retainer(High temperature)



LMHP_L FLANGED LONG LINEAR BUSHING-SUS SERIES

PART NUMBER		WORKING BORE DIAMETER		D		L		D ₁		ℓ	H	W	A	F	d ₁	d ₂	h	SQUAR ENESS ※(μm)	BASIC LOAD RATING(N) ^{★1}		NO. OF BALL ROW	WEIGHT (gf) ^{★2}
Resin	Steel	dr. (mm)	Tolerance (mm)	mm	Tolerance (mm)	mm	Tolerance (mm)	mm	Tolerance (mm)										DYNAMIC (C) ^{★1}	STATIC (Co)		
LMHP06LUU-SUS	LMHP06L-SUSA	6	0 -0.010	12	0 -0.013	35	0 -0.3	28	0 -0.2	5	5	18	20		3.4	6.5	3.2	15	320	520	4	31
LMHP08LUU-SUS	LMHP08L-SUSA	8		15		45		32		5	5	21	24		3.4	6.5	3.2	15	430	780	4	53
LMHP10LUU-SUS	LMHP10L-SUSA	10		19	55	40		6		6	25	29		4.5	8	4.2	15	580	1,100	4	105	
LMHP12LUU-SUS	LMHP12L-SUSA	12		21	0 -0.016	57		42		6	6	27	32		4.5	8	4.2	15	650	1,200	4	100
LMHP13LUU-SUS	LMHP13L-SUSA	13		23		61				43	6	6	29	33		4.5	8	4.2	15	810	1,570	4
LMHP16LUU-SUS	LMHP16L-SUSA	16		28	70	48		6		6	34	31	22	4.5	8	4.2	15	1,230	2,350	5	187	
LMHP20UU-SUS	LMHP20L-SUSA	20	0 -0.012	32	80	54	8	8	38	36	24	5.5	9.5	5.2	20	1,400	2,750	5	260			
LMHP25LUU-SUS	LMHP25L-SUSA	25		40	0 -0.019	112	62	8	8	46	40	32	5.5	9.5	5.2	20	1,560	3,140	6	515		
LMHP30LUU-SUS	LMHP30L-SUSA	30		45		123		74	10	10	51	49	35	6.6	11	6.5	20	2,940	5,490	6	655	

★1 Dynamic load rating is based on the nominal life of 50km

★2 Based on the weight of resin retainer

★3 Main unit : mm

★4 1N ≒ 0.102kgf

LMFM FLANGED LONG LINEAR BUSHING-SUS SERIES

● Drawing

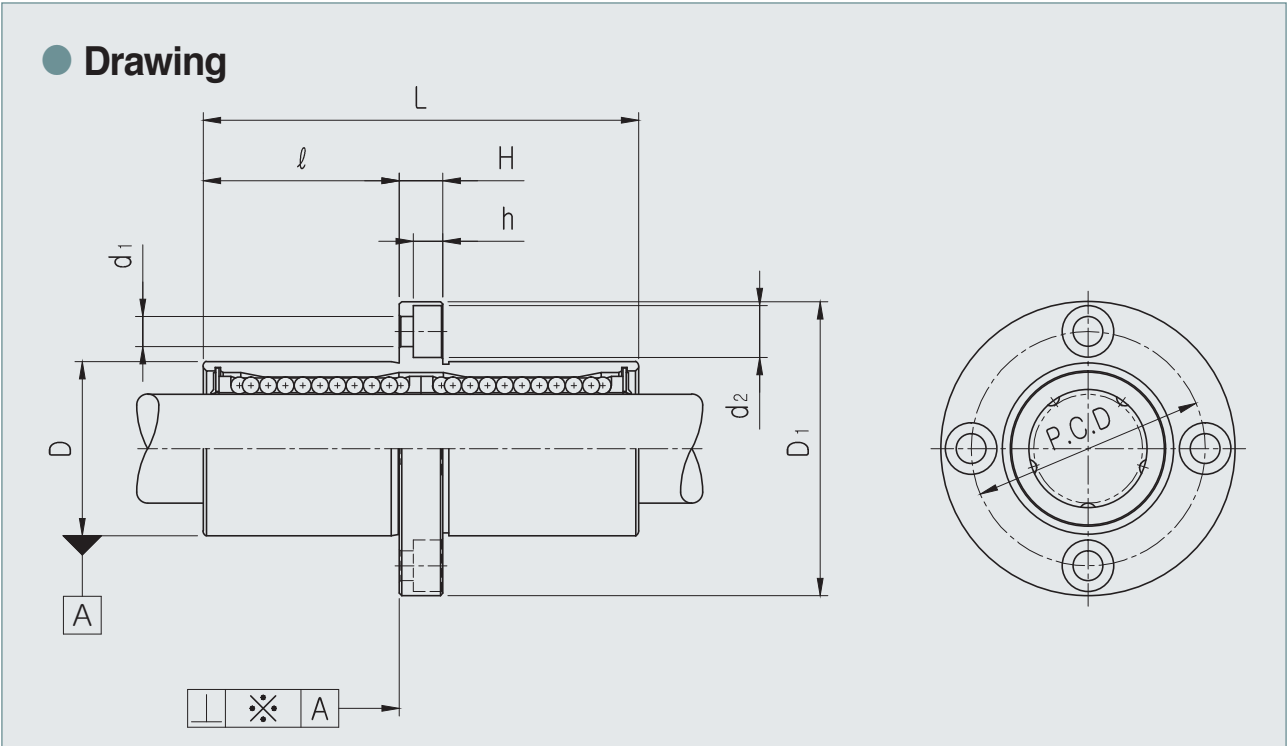

● Part Number Notation

LMFM 20 UU - SUS A

- SAMICK Square Middle Flanged Linear Bushing
- Nominal Shaft Diameter
- Seal

Blank	No Seal
UU	Both Side Seal
U	One Side Seal

- Outer-sleeves : Stainless Steel
- BALL : Stainless Steel
- Retainer (material)

Blank	Resin Retainer(Standard)
A	Steel Retainer(High temperature)



LMFM FLANGED LONG LINEAR BUSHING-SUS SERIES

PART NUMBER		WORKING BORE DIAMETER		D		L		D ₁		ℓ	H	PCD	d ₁	d ₂	h	SQUAR ENESS ※(μm)	BASIC LOAD RATING(N) ^{★1}		NO. OF BALL ROW	WEIGHT (gf) ^{★2}		
Resin	Steel	dr. (mm)	Tolerance (mm)	mm	Tolerance (mm)	mm	Tolerance (mm)	mm	Tolerance (mm)								DYNAMIC (C) ^{★1}	STATIC (Co)				
LMFM06UU-SUS	LMFM06-SUSA	6	0 -0.010	12	0	35	0 -0.3	28	0 -0.2	15	5	20	3.4	6.5	3.2	15	320	520	4	31		
LMFM08UU-SUS	LMFM08-SUSA	8		15	-0.013	45		32		20	5	24	3.4	6.5	3.2	15	430	780	4	53		
LMFM10UU-SUS	LMFM10-SUSA	10		19	55	40		24.5		6	29	4.5	8	4.2	15	580	1,100	4	105			
LMFM12UU-SUS	LMFM12-SUSA	12		21	0	57		0		25.5	6	32	4.5	8	4.2	15	650	1,200	4	100		
LMFM13UU-SUS	LMFM13-SUSA	13		23	-0.016	61		43		27.5	6	33	4.5	8	4.2	15	810	1,570	4	130		
LMFM16UU-SUS	LMFM16-SUSA	16		28	70	48		32		6	38	4.5	8	4.2	15	1,230	2,350	5	187			
LMFM20UU-SUS	LMFM20-SUSA	20		32	80	54		36		8	43	5.5	9.5	5.2	20	1,400	2,750	5	260			
LMFM25UU-SUS	LMFM25-SUSA	25		0	40	0		112		0	62	52	8	51	5.5	9.5	5.2	20	1,560	3,140	6	515
LMFM30UU-SUS	LMFM30-SUSA	30		-0.012	45	0		123		-0.4	74	56.5	10	60	6.6	11	6.5	20	2,490	5,490	6	655

★1 Dynamic load rating is based on the nominal life of 50km

★2 Based on the weight of resin retainer

★3 Main unit : mm

★4 1N ≒ 0.102kgf

LMKM FLANGED LONG LINEAR BUSHING-SUS SERIES

● Drawing

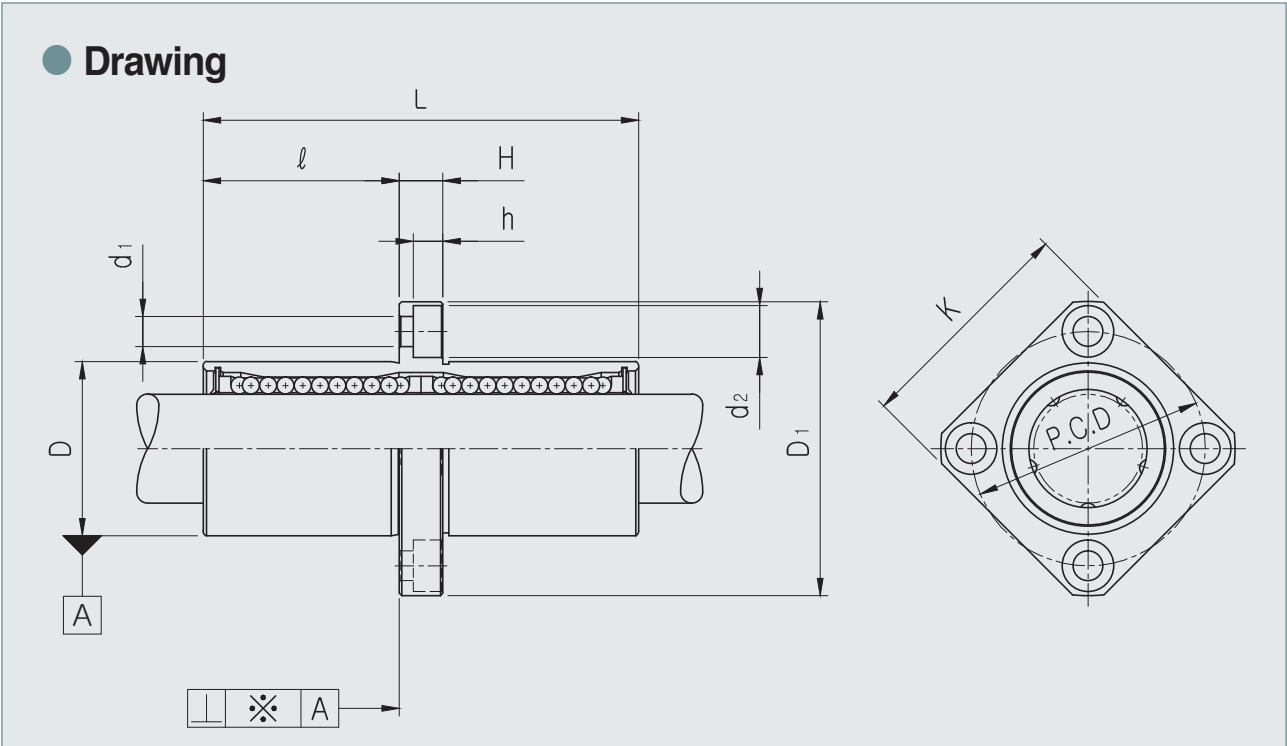

● Part Number Notation

LMKM 20 UU - SUS A

- SAMICK Square Middle Flanged Linear Bushing
- Nominal Shaft Diameter
- Linear Bushing Long Type (for high load)

Blank	No Seal
UU	Both Side Seal
U	One Side Seal

- Outer-sleeves : Stainless Steel
- BALL : Stainless Steel
- Retainer (material)

Blank	Resin Retainer(Standard)
A	Steel Retainer(High temperature)

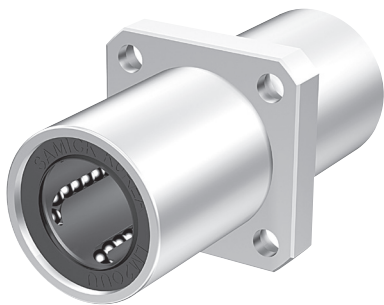

LMKM FLANGED LONG LINEAR BUSHING-SUS SERIES

PART NUMBER		WORKING BORE DIAMETER		D		L		D ₁		ℓ	H	PCD	K	d ₁	d ₂	h	SQUAREDNESS ※(μm)	BASIC LOAD RATING(N) ^{★4}		NO. OF BALL ROW	WEIGHT (gf) ^{★2}			
Resin	Steel	dr. (mm)	Tolerance (mm)	mm	Tolerance (mm)	mm	Tolerance (mm)	mm	Tolerance (mm)									DYNAMIC (C) ^{★1}	STATIC (Co)					
LMKM06UU-SUS	LMKM06-SUSA	6	0 -0.010	12	0 -0.013	35	0 -0.3	28	0 -0.2	15	5	20	22	3.4	6.5	3.2	15	320	520	4	31			
LMKM08UU-SUS	LMKM08-SUSA	8		15		45		32		20	5	24	25	3.4	6.5	3.2	15	430	780	4	53			
LMKM10UU-SUS	LMKM10-SUSA	10		19	55	40		24.5		6	29	30	4.5	8	4.2	15	580	1,100	4	105				
LMKM12UU-SUS	LMKM12-SUSA	12		21	57	42		25.5		6	32	32	4.5	8	4.2	15	650	1,200	4	100				
LMKM13UU-SUS	LMKM13-SUSA	13		23	61	43		27.5		6	33	34	4.5	8	4.2	15	810	1,570	4	130				
LMKM16UU-SUS	LMKM16-SUSA	16		28	70	48		32		6	38	37	4.5	8	4.2	15	1,230	2,350	5	187				
LMKM20UU-SUS	LMKM20-SUSA	20		32	80	54		36		8	43	42	5.5	9.5	5.2	20	1,400	2,750	5	260				
LMKM25UU-SUS	LMKM25-SUSA	25		0 -0.012	40	0 -0.019		112		0 -0.4	62	0 -0.2	52	8	51	50	5.5	9.5	5.2	20	1,560	3,140	6	515
LMKM30UU-SUS	LMKM30-SUSA	30		45	123	74		56.5			10		60	58	6.6	11	6.5	20	2,490	5,490	6	655		

★1 Dynamic load rating is based on the nominal life of 50km

★2 Based on the weight of resin retainer

★3 Main unit : mm

★4 1N ≒ 0.102kgf

LMHM FLANGED LONG LINEAR BUSHING-SUS SERIES

● Drawing

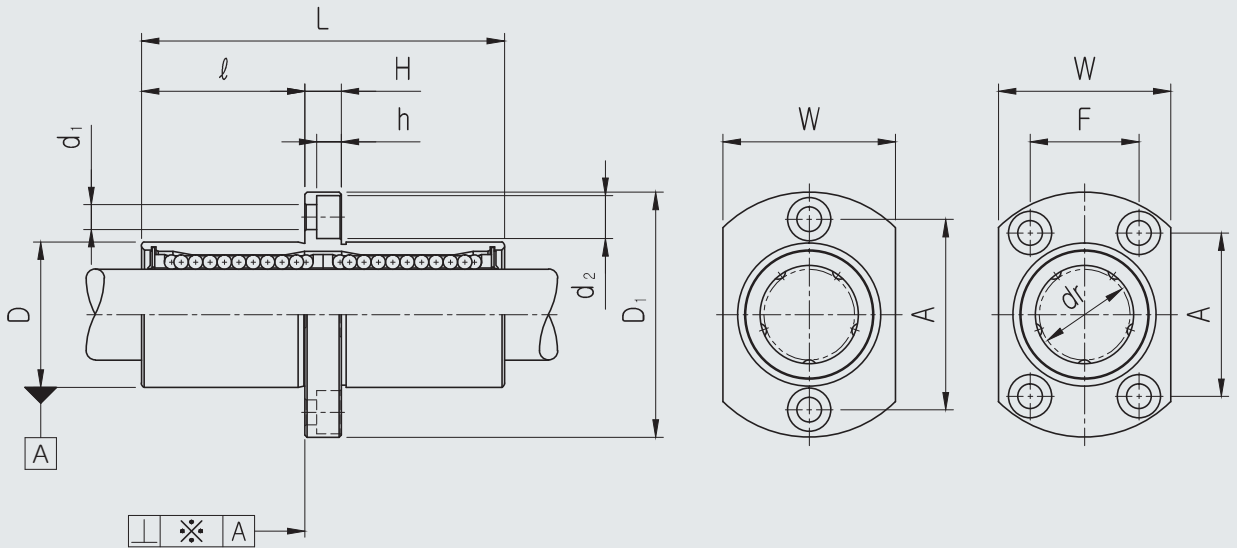

● Part Number Notation

LMHM 20 UU - SUS A

- SAMICK Oval Middle Flanged Linear Bushing
- Nominal Shaft Diameter
- Seal

Blank	No Seal
UU	Both Side Seal
U	One Side Seal

- Outer-sleeves : Stainless Steel
- BALL : Stainless Steel
- Retainer (material)

Blank	Resin Retainer(Standard)
A	Steel Retainer(High temperature)

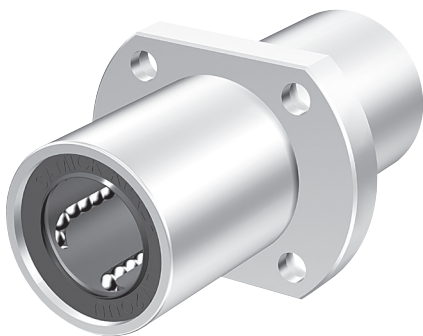

LMHM FLANGED LONG LINEAR BUSHING-SUS SERIES

PART NUMBER		WORKING BORE DIAMETER		D		L		D ₁		ℓ	H	W	A	F	d ₁	d ₂	h	SQUAREDNESS ※(μm)	BASIC LOAD RATING(N) ^{★4}		NO. OF BALL ROW	WEIGHT (gf) ^{★2}			
Resin	Steel	dr. (mm)	Tolerance (mm)	mm	Tolerance (mm)	mm	Tolerance (mm)	mm	Tolerance (mm)									DYNAMIC (C) ^{★1}	STATIC (Co)						
LMHM06UU-SUS	LMHM06-SUSA	6	0 -0.010	12	0 -0.013	35	0 -0.3	28	0 -0.2	15	5	18	20		3.4	6.5	3.2	15	320	520	4	31			
LMHM08UU-SUS	LMHM08-SUSA	8		15		45		32		20	5	21	24		3.4	6.5	3.2	15	430	780	4	53			
LMHM10UU-SUS	LMHM10-SUSA	10		19	55	40		24.5		6	25	29		4.5	8	4.2	15	580	1,100	4	105				
LMHM12UU-SUS	LMHM12-SUSA	12		21	57	42		25.5		6	27	32		4.5	8	4.2	15	650	1,200	4	100				
LMHM13UU-SUS	LMHM13-SUSA	13		23	61	43		27.5		6	29	33		4.5	8	4.2	15	810	1,570	4	130				
LMHM16UU-SUS	LMHM16-SUSA	16		28	70	48		32		6	34	31	22	4.5	8	4.2	15	1,230	2,350	5	187				
LMHM20UU-SUS	LMHM20-SUSA	20		32	80	54		36		8	38	36	24	5.5	9.5	5.2	20	1,400	2,750	5	260				
LMHM25UU-SUS	LMHM25-SUSA	25		0 -0.012	40	0 -0.019		112		0 -0.4	62	0 -0.2	52	8	46	40	32	5.5	9.5	5.2	20	1,560	3,140	6	515
LMHM30UU-SUS	LMHM30-SUSA	30		45	123	74		56.5			10		51	49	35	6.6	11	6.5	20	2,490	5,490	6	655		

★1 Dynamic load rating is based on the nominal life of 50km

★2 Based on the weight of resin retainer

★3 Main unit : mm

★4 1N ≒ 0.102kgf

217

SUS SERIES EUROPEAN STANDARD (LME-SUS)

LME CLOSED LINEAR BUSHING-SUS SERIES

● Drawing

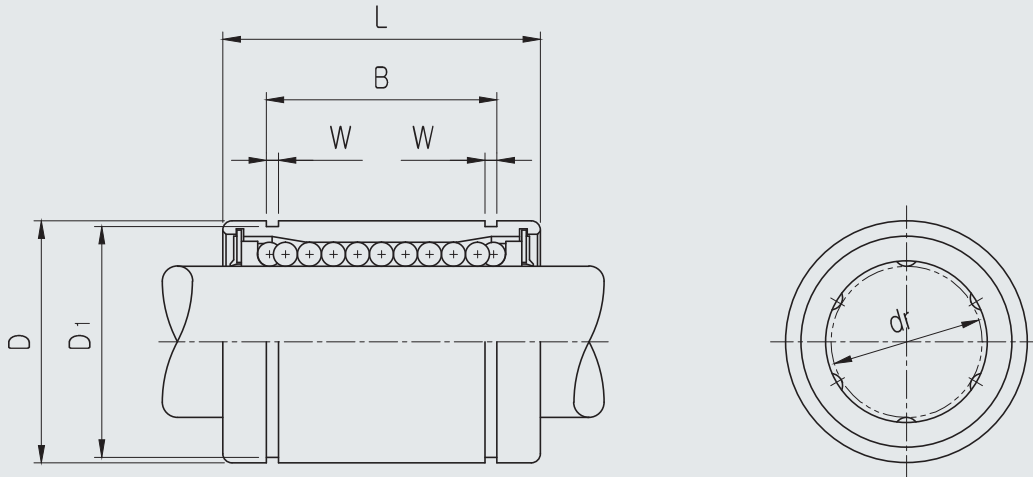

● Part Number Notation

LME 20 UU - SUS A



- European Standard Samick Linear Bushing
- Nominal Shaft Diameter
- Seal

Blank	No Seal
UU	Both Side Seal
U	One Side Seal

- Outer-sleeves : Stainless Steel
- BALL : Stainless Steel
- Retainer (material)

Blank	Resin Retainer(Standard)
A	Steel Retainer(High temperature) ^{★1}

★1 LME05 available with resin retainer only

LME CLOSED LINEAR BUSHING-SUS SERIES

PART NUMBER		WORKING BORE DIAMETER		D		L		B		W	D ₁	BASIC LOAD RATING(N) ^{*4}		NO. OF BALL ROW	WEIGHT (gf) ^{*2}
Resin	Steel ^{*5}	dr. (mm)	Tolerance (mm)	mm	Tolerance (mm)	mm	Tolerance (mm)	mm	Tolerance (mm)			DYNAMIC (C) ^{*1}	STATIC (Co)		
LME05UU-SUS		5	+0.008 0	12	0 -0.008	22	0 -0.2	14.5	0 -0.2	1.1	11.5	200	260	4	12
LME08UU-SUS	LME08-SUSA	8		16		25		16.5		1.1	15.2	260	400	4	20
LME12UU-SUS	LME12-SUSA	12	+0.009 -0.001	22	0 -0.009	32	0 -0.3	22.9	0 -0.3	1.3	21	410	590	4	41
LME16UU-SUS	LME16-SUSA	16		26		36		24.9		1.3	24.9	770	1,170	5	57
LME20UU-SUS	LME20-SUSA	20		32		45		31.5		1.6	30.3	860	1,370	5	91
LME25UU-SUS	LME25-SUSA	25	+0.011 -0.001	40	0 -0.011	58	0 -0.3	44.1	0 -0.3	1.85	37.5	980	1,560	6	215
LME30UU-SUS	LME30-SUSA	30		47		68		52.1		1.85	44.5	1,560	2,740	6	325

- ★1 Dynamic load rating is based on the nominal life of 50km
- ★2 Based on the weight of resin retainer
- ★3 Main unit : mm
- ★4 1N ≒ 0.102kgf
- ★5 LME08 to LME30 applicable with steel retainer only

LME_L LONG LINEAR BUSHING-SUS SERIES

● Drawing

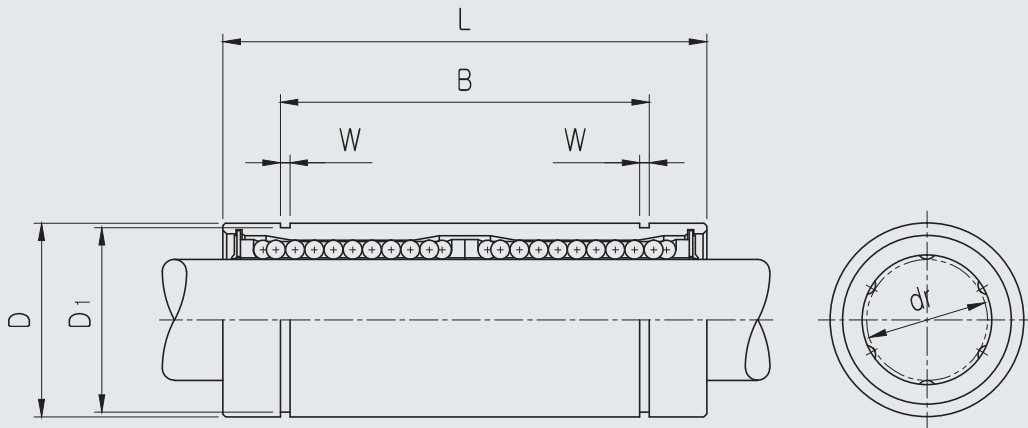

● Part Number Notation

LME 20 L UU - SUS A



- European Standard Samick Linear Bushing
- Nominal Shaft Diameter
- Linear Bushing Long Type (for high load)
- Seal

Blank	No Seal
UU	Both Side Seal
U	One Side Seal

- Outer-sleeves : Stainless Steel
- BALL : Stainless Steel
- Retainer (material)

Blank	Resin Retainer(Standard)
A	Steel Retainer(High temperature)

LME_L LONG LINEAR BUSHING-SUS SERIES

PART NUMBER		WORKING BORE DIAMETER		D		L		B		W	D ₁	BASIC LOAD RATING(N) ^{*4}		NO. OF BALL ROW	WEIGHT (gf) ^{*2}
Resin	Steel	dr. (mm)	Tolerance (mm)	mm	Tolerance (mm)	mm	Tolerance (mm)	mm	Tolerance (mm)			DYNAMIC (C) ^{*1}	STATIC (Co)		
LME08LUU-SUS	LME08L-SUSA	8	+0.009 -0.001	16	0 -0.009	45	0 -0.3	33	0 -0.3	1.1	15.2	430	780	4	31
LME12LUU-SUS	LME12L-SUSA	12		22	0 -0.011	57		45.8		1.3	21	650	1,200	4	80
LME16LUU-SUS	LME16L-SUSA	16	+0.011 -0.001	26	0 -0.013	70	0 -0.4	49.8	0 -0.4	1.3	24.9	1,230	2,350	5	145
LME20LUU-SUS	LME20L-SUSA	20		32		80		61		1.6	30.3	1,400	2,750	5	180
LME25LUU-SUS	LME25L-SUSA	25	+0.013 -0.002	40	0 -0.013	112	0 -0.4	82	0 -0.4	1.85	38	1,560	3,140	6	440
LME30LUU-SUS	LME30L-SUSA	30		47		123		104.2		1.85	44.5	2,490	5,490	6	580

★1 Dynamic load rating is based on the nominal life of 50km

★2 Based on the weight of resin retainer

★3 Main unit : mm

★4 1N ≙ 0.102kgf

LME_AJ ADJUSTABLE LINEAR BUSHING-SUS SERIES

● Drawing

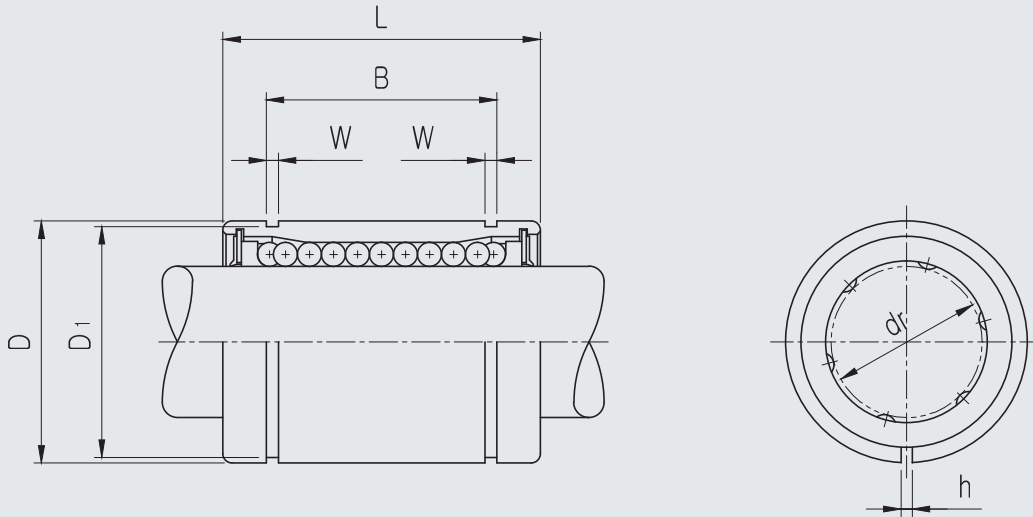

● Part Number Notation

LME 20 UU AJ - SUS A

- European Standard Samick Linear Bushing
- Nominal Shaft Diameter
- Seal

Blank	No Seal
UU	Both Side Seal
U	One Side Seal

- Linear Bushing Adjustable type
- Outer-sleeves : Stainless Steel
- BALL : Stainless Steel
- Retainer (material)

Blank	Resin Retainer(Standard)
A	Steel Retainer(High temperature)



LME_AJ ADJUSTABLE LINEAR BUSHING-SUS SERIES

PART NUMBER		WORKING BORE DIAMETER		D*4		L		B		W	D ₁	h	BASIC LOAD RATING(N) ^{*5}		NO. OF BALL ROW	WEIGHT (gf) ^{*2}
Resin	Steel	dr. (mm)	Tolerance (mm)	mm	Tolerance (mm)	mm	Tolerance (mm)	mm	Tolerance (mm)				DYNAMIC (C) ^{*1}	STATIC (Co)		
LME08UUAJ-SUS	LME08AJ-SUSA	8	+0.008 0	16	0 -0.008	25	0 -0.2	16.5	0 -0.2	1.1	15.2	1	260	400	4	20
LME12UUAJ-SUS	LME12AJ-SUSA	12		22	32	22.9		1.3		21	1.5	410	590	4	41	
LME16UUAJ-SUS	LME16AJ-SUSA	16	+0.009 -0.001	26	0 -0.009	36	0 -0.2	24.9	0 -0.2	1.3	24.9	1.5	770	1,170	5	57
LME20UUAJ-SUS	LME20AJ-SUSA	20		32		45		31.5		1.6	30.3	2	860	1,370	5	91
LME25UUAJ-SUS	LME25AJ-SUSA	25	+0.011 -0.001	40	0 -0.011	58	0 -0.3	44.1	0 -0.3	1.85	37.5	2	980	1,560	6	215
LME30UUAJ-SUS	LME30AJ-SUSA	30		47		68		52.1		1.85	44.5	2	1,560	2,740	6	325

★1 Dynamic load rating is based on the nominal life of 50km

★2 Based on the weight of resin retainer

★3 Main unit : mm

★4 Outer diameter is the obtained value before the slotting process.

★5 1N ≒ 0.102kgf

LME_OP OPEN LINEAR BUSHING-SUS SERIES

● Drawing

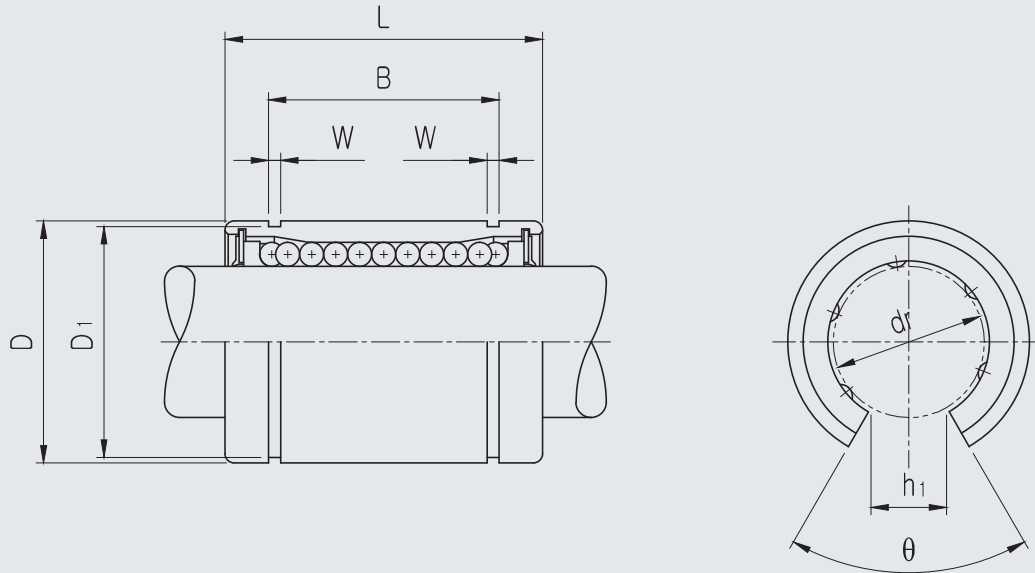

● Part Number Notation

LME 20 UU OP - SUS

- European Standard Samick Linear Bushing
- Nominal Shaft Diameter
- Seal

UU	Both Side Seal ^{★1}
----	------------------------------
- Linear Bushing Open type
- Outer-sleeves : Stainless Steel
Ball type : Stainless Steel

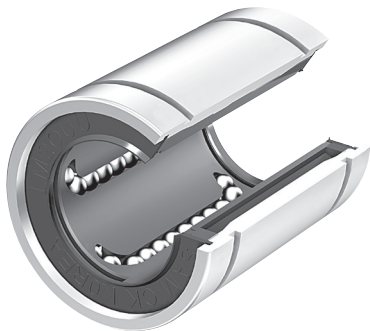

* ★1 UU type only available.
 No seal type & One side seal type not available.
 ★ Resin retainer only applicable

LME_OP OPEN LINEAR BUSHING-SUS SERIES

PART NUMBER	WORKING BORE DIAMETER		D*4		L		B		W	D ₁	h	θ	BASIC LOAD RATING(N) ^{*5}		NO. OF BALL ROW	WEIGHT (gf) ^{*2}
	Resin	dr. (mm)	Tolerance (mm)	mm	Tolerance (mm)	mm	Tolerance (mm)	mm					Tolerance (mm)	DYNAMIC (C) ^{*1}		
LME12UUOP-SUS	12	+0.008 0	22	0 -0.009	32	0 -0.2	22.9	0 -0.2	1.3	21	7.5	78°	410	590	3	41
LME16UUOP-SUS	16	+0.009 -0.001	26		36		24.9		1.3	24.9	10	78°	770	1,170	4	57
LME20UUOP-SUS	20		+0.011 -0.0011	32	45	31.5	1.6	30.3	10	60°	860	1,370	4	91		
LME25UUOP-SUS	25	40		0 -0.011	58	0 -0.3	44.1	0 -0.3	1.85	37.5	12.5	60°	980	1,560	5	215
LME30UUOP-SUS	30	47	68	52.1	1.85	44.5	12.5	50°	1,560	2,740	5	325				

★1 Dynamic load rating is based on the nominal life of 50km

★2 Based on the weight of resin retainer

★3 Main unit : mm

★4 Outer diameter is the obtained value before the slotting process.

★5 1N ≙ 0.102kgf

LMEF FLANGED LINEAR BUSHING-SUS SERIES

● Drawing

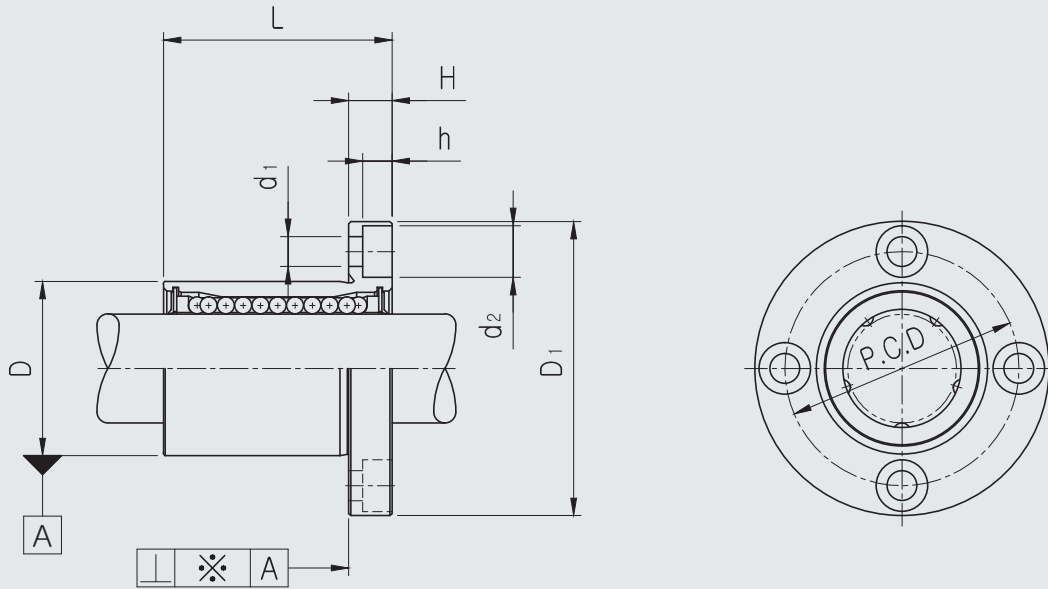

● Part Number Notation

LMEF 20 UU - SUS A

- European Standard Samick Circular Flanged Linear Bushing
- Nominal Shaft Diameter
- Seal

Blank	No Seal
UU	Both Side Seal
U	One Side Seal

- Outer-sleeves : Stainless Steel
- BALL : Stainless Steel
- Retainer (material)

Blank	Resin Retainer(Standard)
A	Steel Retainer(High temperature)



LMEF FLANGED LINEAR BUSHING-SUS SERIES

PART NUMBER		WORKING BORE DIAMETER		D		L		B		H	PCD	d ₁	d ₂	h	SQUAR ENESS ※(μm)	BASIC LOAD RATING(N) ^{★4}		NO. OF BALL ROW	WEIGHT (gf) ^{★2}
Resin	Steel	dr. (mm)	Tolerance (mm)	mm	Tolerance (mm)	mm	Tolerance (mm)	mm	Tolerance (mm)							DYNAMIC (C) ^{★1}	STATIC (Co)		
LMEF08UU-SUS	LMEF08-SUSA	8	+0.008 0	16	0 -0.008	25	±0.2	32	0 -0.2	5	24	3.4	6.5	3.2	12	260	400	4	44
LMEF12UU-SUS	LMEF12-SUSA	12	+0.009 -0.001	22	0 -0.009	32		42		6	32	4.5	8	4.2	12	410	590	4	86
LMEF16UU-SUS	LMEF16-SUSA	16		+0.011 -0.001	26	0 -0.011	36	±0.3	46	8	36	4.5	8	4.2	12	770	1,170	5	120
LMEF20UU-SUS	LMEF20-SUSA	20	32		45		54		8		43	5.5	9.5	5.2	15	860	1,370	5	184
LMEF25UU-SUS	LMEF25-SUSA	25	+0.011 -0.001	40	0 -0.011	58	±0.3	62	10	51	5.5	9.5	5.2	15	980	1,560	6	335	
LMEF30UU-SUS	LMEF30-SUSA	30		47		68		76		62	6.6	11	6.5	15	1,560	2,470	6	545	

★1 Dynamic load rating is based on the nominal life of 50km

★2 Based on the weight of resin retainer

★3 Main unit : mm

★4 1N ≒ 0.102kgf

LMEF_L FLANGED LONG LINEAR BUSHING-SUS SERIES

● Drawing

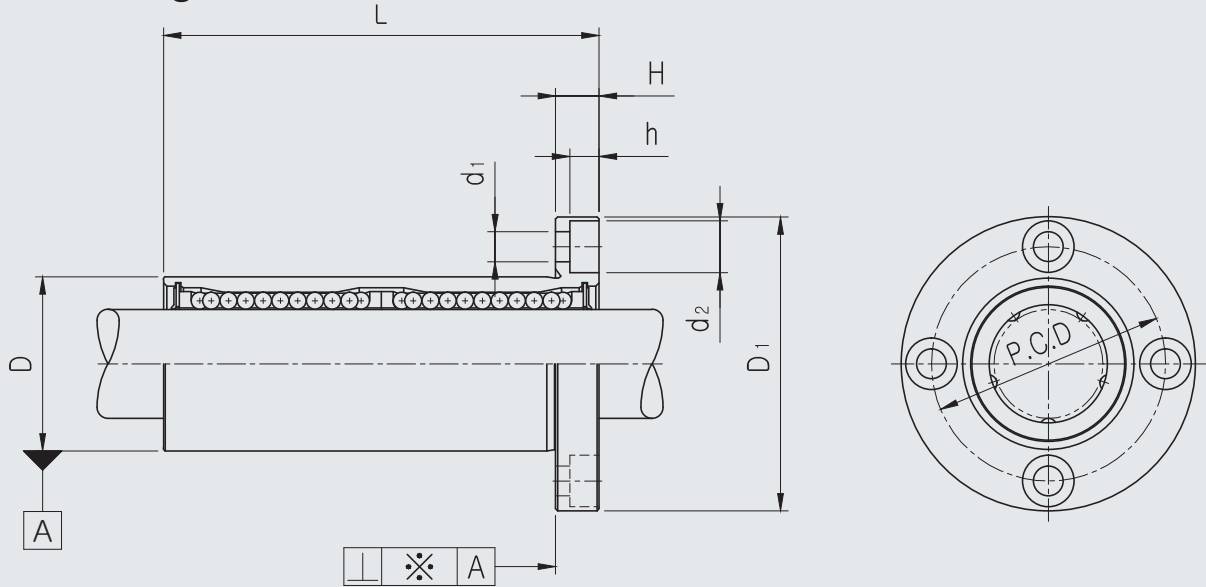

● Part Number Notation

LMEF 20 L UU - SUS A

- European Standard Samick Circular Flanged Linear Bushing
- Nominal Shaft Diameter
- Linear Bushing Long Type (for high load)
- Seal

Blank	No Seal
UU	Both Side Seal
U	One Side Seal

- Outer-sleeves : Stainless Steel

BALL : Stainless Steel

- Retainer (material)

Blank	Resin Retainer(Standard)
A	Steel Retainer(High temperature)



LMEF_L FLANGED LONG LINEAR BUSHING-SUS SERIES

PART NUMBER		WORKING BORE DIAMETER		D		L		B		H	PCD	d ₁	d ₂	h	SQUAR ENESS ※(μm)	BASIC LOAD RATING(N) ^{*4}		NO. OF BALL ROW	WEIGHT (gf) ^{*2}
Resin	Steel	dr. (mm)	Tolerance (mm)	mm	Tolerance (mm)	mm	Tolerance (mm)	mm	Tolerance (mm)							DYNAMIC (C) ^{*1}	STATIC (Co)		
LMEF08LUU-SUS	LMEF08L-SUSA	8	+0.009 -0.001	16	0 -0.009	45	±0.3	32	0 -0.2	5	24	3.4	6.5	3.2	15	430	780	4	53
LMEF12LUU-SUS	LMEF12L-SUSA	12		22	0 -0.0011	57		42		6	32	4.5	8	4.2	15	650	1,200	4	100
LMEF16LUU-SUS	LMEF16L-SUSA	16	+0.011 -0.001	26	0 -0.013	70	±0.4	46	0 -0.2	6	36	4.5	8	4.2	15	1,230	2,350	5	187
LMEF20LUU-SUS	LMEF20L-SUSA	20		32		80		54		8	43	5.5	9.5	5.2	17	1,400	2,750	5	260
LMEF25LUU-SUS	LMEF25L-SUSA	25	+0.013 -0.002	40	0 -0.013	112	±0.4	62	0 -0.2	8	51	5.5	9.5	5.2	17	1,560	3,140	6	515
LMEF30LUU-SUS	LMEF30L-SUSA	30		47		123		76		10	62	6.6	11	6.5	17	2,490	5,490	6	655

★1 Dynamic load rating is based on the nominal life of 50km

★2 Based on the weight of resin retainer

★3 Main unit : mm

★4 1N ≒ 0.102kgf

LMEK FLANGED LINEAR BUSHING-SUS SERIES

● Drawing

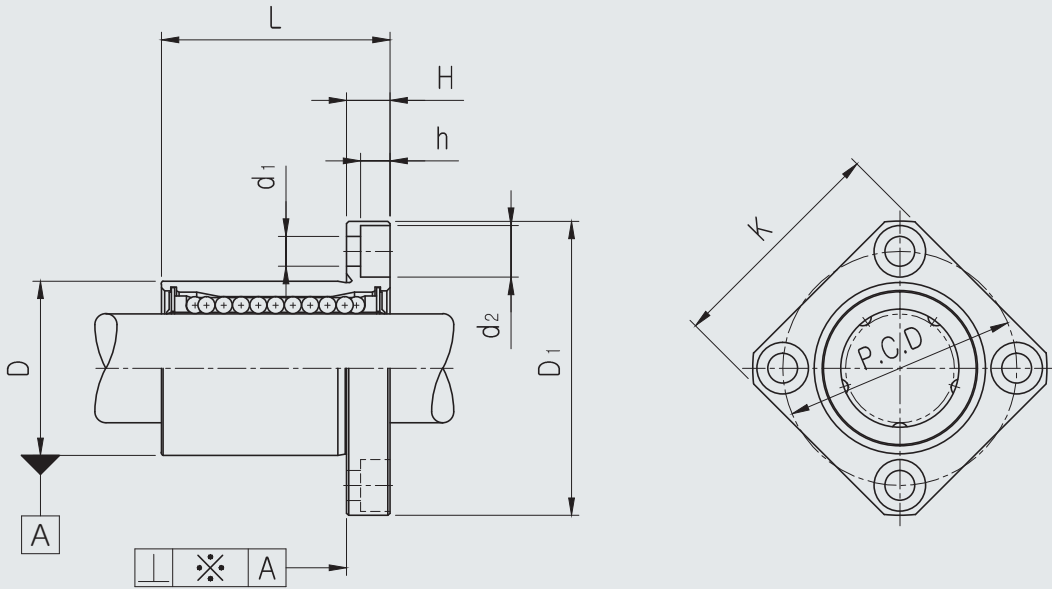

● Part Number Notation

LMEK 20 UU - SUS A

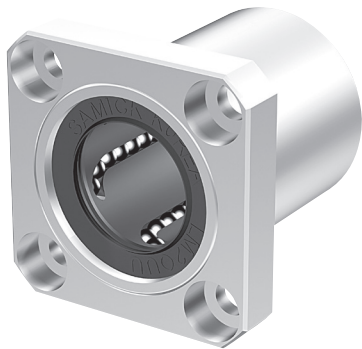

- European Standard Samick Square Flanged Linear Bushing
- Nominal Shaft Diameter
- Seal

Blank	No Seal
UU	Both Side Seal
U	One Side Seal

- Outer-sleeves : Stainless Steel
- BALL : Stainless Steel
- Retainer (material)

Blank	Resin Retainer(Standard)
A	Steel Retainer(High temperature)

LMEK FLANGED LINEAR BUSHING-SUS SERIES

PART NUMBER		WORKING BORE DIAMETER		D		L		D ₁		H	PCD	K	d ₁	d ₂	h	SQUAR ENESS ※(μm)	BASIC LOAD RATING(N) ^{*4}		NO. OF BALL ROW	WEIGHT (gf) ^{*2}
Resin	Steel	dr. (mm)	Tolerance (mm)	mm	Tolerance (mm)	mm	Tolerance (mm)	mm	Tolerance (mm)							DYNAMIC (C) ^{*1}	STATIC (Co)			
LMEK08UU-SUS	LMEK08-SUSA	8	+0.008 0	16	0 -0.008	25	±0.2	32	0 -0.2	5	24	25	3.4	6.5	3.2	12	260	400	4	44
LMEK12UU-SUS	LMEK12-SUSA	12		22	0 -0.009	32		42		6	32	32	4.5	8	4.2	12	410	590	4	86
LMEK16UU-SUS	LMEK16-SUSA	16	+0.009 -0.001	26		36	46	6		36	35	4.5	8	4.2	12	770	1,170	5	120	
LMEK20UU-SUS	LMEK20-SUSA	20		32		45	54	8		43	42	5.5	9.5	5.2	15	860	1,370	5	184	
LMEK25UU-SUS	LMEK25-SUSA	25	+0.011 -0.001	40	0 -0.011	58	±0.3	62		8	51	50	5.5	9.5	5.2	15	980	1,560	6	335
LMEK30UU-SUS	LMEK30-SUSA	30		47		68		76		10	62	60	6.6	11	6.5	15	1,560	2,470	6	545

★1 Dynamic load rating is based on the nominal life of 50km

★2 Based on the weight of resin retainer

★3 Main unit : mm

★4 1N ≒ 0.102kgf

LMEK_L FLANGED LONG LINEAR BUSHING-SUS SERIES

● Drawing

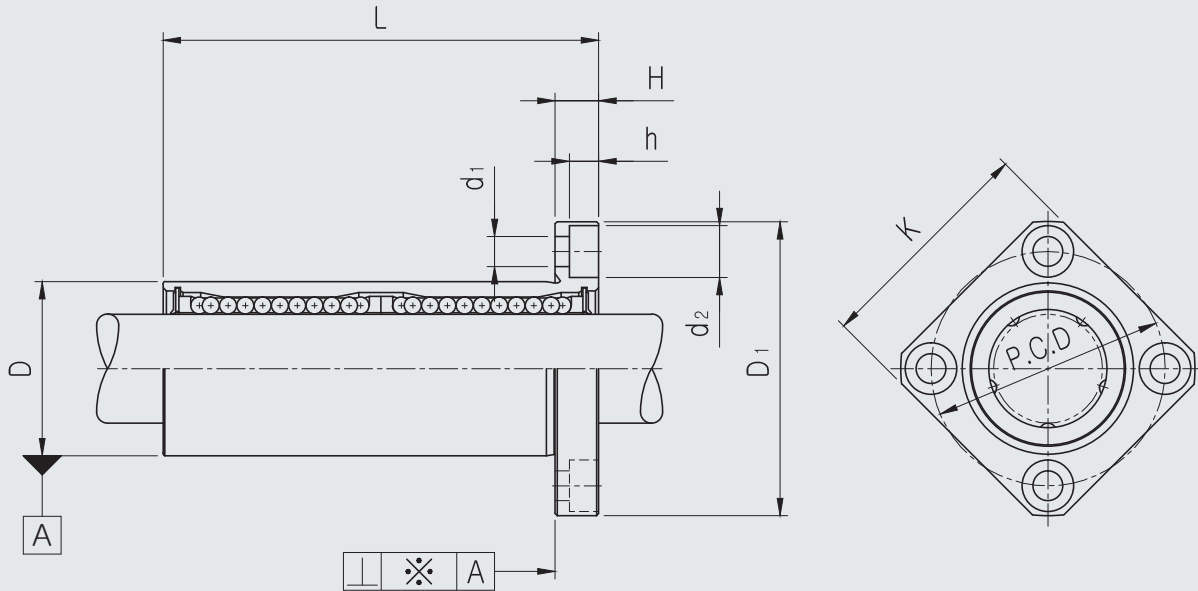

● Part Number Notation

LMEK 20 L UU - SUS A

- European Standard Samick Square Flanged Linear Bushing
- Nominal Shaft Diameter
- Linear Bushing Long Type (for high load)
- Seal

Blank	No Seal
UU	Both Side Seal
U	One Side Seal

- Outer-sleeves : Stainless Steel

Ball type : Stainless Steel

- Retainer (material)

Blank	Resin Retainer(Standard)
A	Steel Retainer(High temperature)

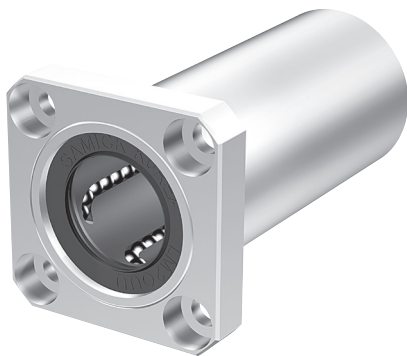

LMEK_L FLANGED LONG LINEAR BUSHING-SUS SERIES

PART NUMBER		WORKING BORE DIAMETER		D		L		D ₁		H	PCD	K	d ₁	d ₂	h	SQUAR ENESS ※(μm)	BASIC LOAD RATING(N) ^{★4}		NO. OF BALL ROW	WEIGHT (gf) ^{★2}
Resin	Steel	dr. (mm)	Tolerance (mm)	mm	Tolerance (mm)	mm	Tolerance (mm)	mm	Tolerance (mm)								DYNAMIC (C) ^{★1}	STATIC (Co)		
LMEK08LUU-SUS	LMEK08L-SUSA	8	+0.009 -0.001	16	0 -0.009	45	±0.3	32	0 -0.2	5	24	25	3.4	6.5	3.2	15	430	780	4	53
LMEK12LUU-SUS	LMEK12L-SUSA	12	+0.011 -0.001	22	0 -0.011	57		42		6	32	32	4.5	8	4.2	15	650	1,200	4	100
LMEK16LUU-SUS	LMEK16L-SUSA	16		26	70	46	6	36		35	4.5	8	4.2	15	1,230	2,350	5	187		
LMEK20LUU-SUS	LMEK20L-SUSA	20	32	80	54	8	43	42		5.5	9.5	5.2	17	1,400	2,750	5	260			
LMEK25LUU-SUS	LMEK25L-SUSA	25	+0.013 -0.002	40	0 -0.013	112	±0.4	62		8	51	50	5.5	9.5	5.2	17	1,560	3,140	6	515
LMEK30LUU-SUS	LMEK30L-SUSA	30	47	123	76	10		62		60	6.6	11	6.5	17	2,490	5,490	6	655		

★1 Dynamic load rating is based on the nominal life of 50km

★2 Based on the weight of resin retainer

★3 Main unit : mm

★4 1N ≒ 0.102kgf

LMEFP FLANGED LINEAR BUSHING-SUS SERIES

● Drawing

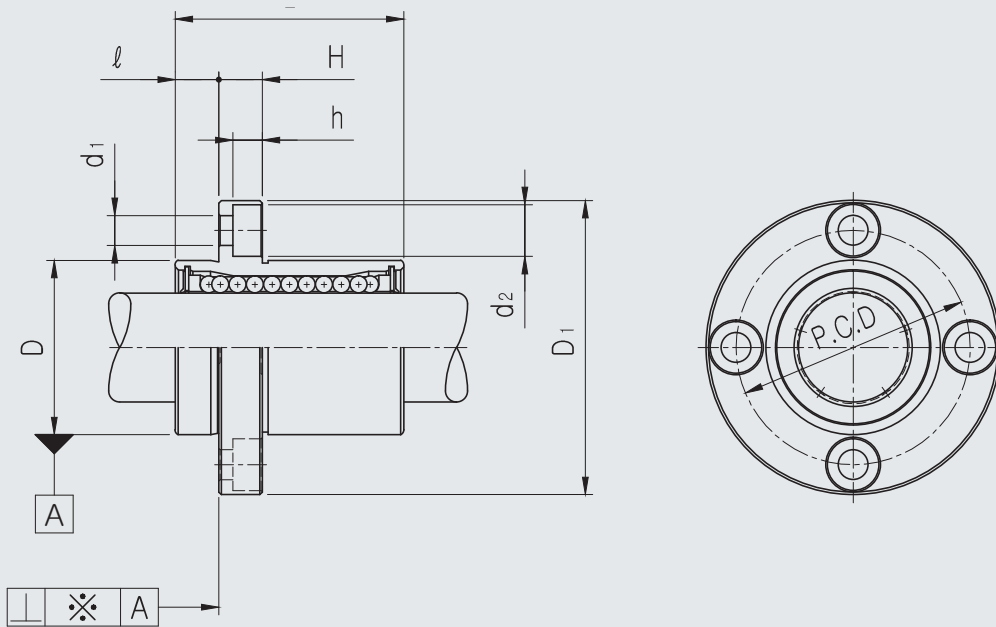

● Part Number Notation

LMEFP 20 UU - SUS A

- European Standard Samick Circular Pilot Flanged Linear Bushing
- Nominal Shaft Diameter
- Seal

Blank	No Seal
UU	Both Side Seal
U	One Side Seal

- Outer-sleeves : Stainless Steel
- BALL : Stainless Steel
- Retainer (material)

Blank	Resin Retainer(Standard)
A	Steel Retainer(High temperature)



LMEFP FLANGED LINEAR BUSHING-SUS SERIES

PART NUMBER		WORKING BORE DIAMETER		D		L		D ₁		ℓ	H	PCD	d ₁	d ₂	h	SQUAREDNESS ※(μm)	BASIC LOAD RATING(N) ^{★4}		NO. OF BALL ROW	WEIGHT (gf) ^{★2}
Resin	Steel	dr. (mm)	Tolerance (mm)	mm	Tolerance (mm)	mm	Tolerance (mm)	mm	Tolerance (mm)								DYNAMIC (C) ^{★1}	STATIC (Co)		
LMEFP08UU-SUS	LMEFP08-SUSA	8	+0.008 0	16	0 -0.008	25		32		5	5	24	3.4	6.5	3.2	12	260	400	4	44
LMEFP12UU-SUS	LMEFP12-SUSA	12		22	0 -0.009	32	0 -0.2	42		6	6	32	4.5	8	4.2	12	410	590	4	86
LMEFP16UU-SUS	LMEFP16-SUSA	16	+0.009 -0.001	26		36		46	0 -0.2	6	6	36	4.5	8	4.2	12	770	1,170	5	120
LMEFP20UU-SUS	LMEFP20-SUSA	20		32		45		54		8	8	43	5.5	9.5	5.2	15	860	1,370	5	184
LMEFP25UU-SUS	LMEFP25-SUSA	25	+0.011 -0.001	40	0 -0.011	58	0 -0.3	62		8	8	51	5.5	9.5	5.2	15	980	1,560	6	335
LMEFP30UU-SUS	LMEFP30-SUSA	30		47		68		76		10	10	62	6.6	11	6.5	15	1,560	2,740	6	545

★1 Dynamic load rating is based on the nominal life of 50km

★2 Based on the weight of resin retainer

★3 Main unit : mm

★4 1N ≒ 0.102kgf

LMEFP_L FLANGED LONG LINEAR BUSHING-SUS SERIES

● Drawing

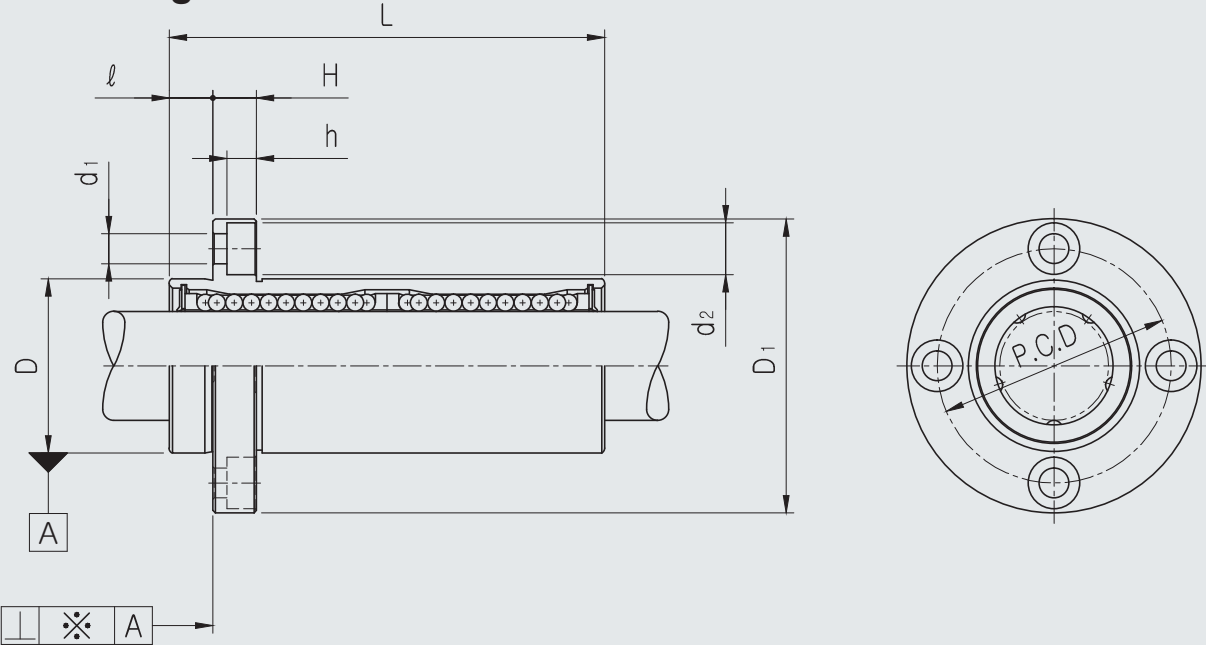

● Part Number Notation

LMEFP 20 L UU - SUS A

- European Standard Samick Circular Pilot Flanged Linear Bushing
- Nominal Shaft Diameter
- Linear Bushing Long Type (for high load)
- Seal

Blank	No Seal
UU	Both Side Seal
U	One Side Seal

- Outer-sleeves : Stainless Steel

BALL : Stainless Steel

- Retainer (material)

Blank	Resin Retainer(Standard)
A	Steel Retainer(High temperature)



LMEFP_L FLANGED LONG LINEAR BUSHING-SUS SERIES

PART NUMBER		WORKING BORE DIAMETER		D		L		D ₁		ℓ	H	PCD	d ₁	d ₂	h	SQUAR ENESS ※(μm)	BASIC LOAD RATING(N) ^{★4}		NO. OF BALL ROW	WEIGHT (gf) ^{★2}
Resin	Steel	dr. (mm)	Tolerance (mm)	mm	Tolerance (mm)	mm	Tolerance (mm)	mm	Tolerance (mm)								DYNAMIC (C) ^{★1}	STATIC (Co)		
LMEFP08LUU-SUS	LMEFP08L-SUSA	8	+0.009 -0.001	16	0 -0.009	45	0 -0.3	32	0 -0.2	5	5	24	3.4	6.5	3.2	15	430	780	4	53
LMEFP12LUU-SUS	LMEFP12L-SUSA	12		22	0 -0.011	57		42		6	6	32	4.5	8	4.2	15	650	1,200	4	100
LMEFP16LUU-SUS	LMEFP16L-SUSA	16	+0.011 -0.001	26	0 -0.013	70	46	6		6	36	4.5	8	4.2	15	1,230	2,350	5	187	
LMEFP20LUU-SUS	LMEFP20L-SUSA	20		32		80	54	8		8	43	5.5	9.5	5.2	17	1,400	2,750	5	260	
LMEFP25LUU-SUS	LMEFP25L-SUSA	25	+0.013 -0.002	40	0 -0.013	112	62	8		8	51	5.5	9.5	5.2	17	1,560	3,140	6	515	
LMEFP30LUU-SUS	LMEFP30L-SUSA	30		47	123	76	10	10		62	6.6	11	6.5	17	2,490	5,490	6	655		

★1 Dynamic load rating is based on the nominal life of 50km

★2 Based on the weight of resin retainer

★3 Main unit : mm

★4 1N ≒ 0.102kgf

LMEKP FLANGED LINEAR BUSHING-SUS SERIES

● Drawing

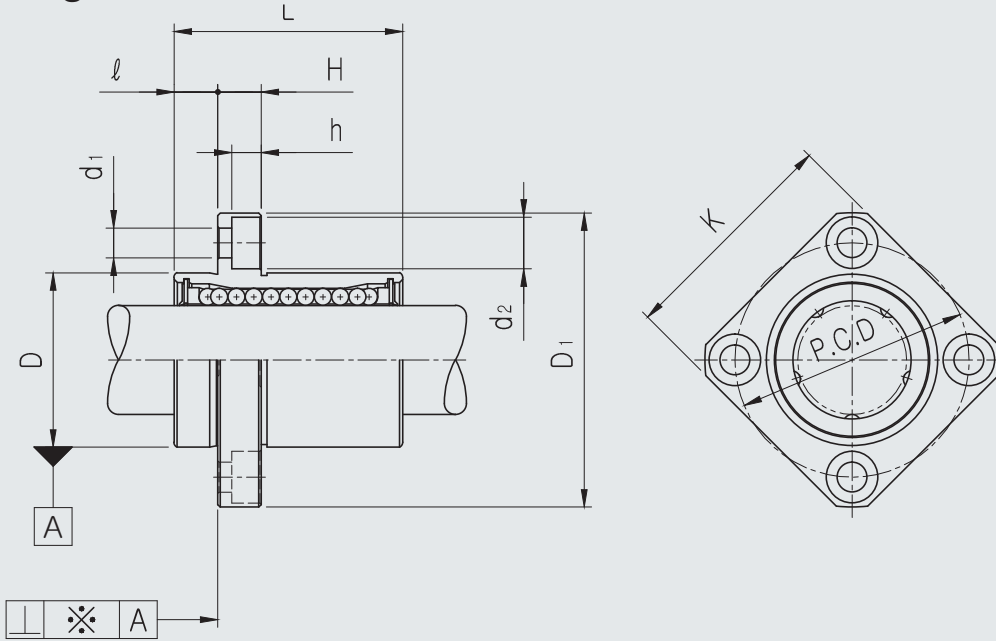

● Part Number Notation

LMEKP 20 UU - SUS A

- European Standard Samick Squared Pilot Flanged Linear Bushing
- Nominal Shaft Diameter
- Seal

Blank	No Seal
UU	Both Side Seal
U	One Side Seal

- Outer-sleeves : Stainless Steel
- BALL : Stainless Steel
- Retainer (material)

Blank	Resin Retainer(Standard)
A	Steel Retainer(High temperature)

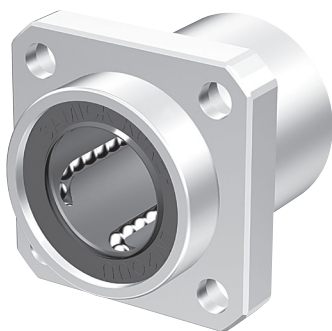

LMEKP FLANGED LINEAR BUSHING-SUS SERIES

PART NUMBER		WORKING BORE DIAMETER		D		L		D ₁		ℓ	H	PCD	K	d ₁	d ₂	h	SQUAREDNESS ※(μm)	BASIC LOAD RATING(N) ^{★1}		NO. OF BALL ROW	WEIGHT (gf) ^{★2}
Resin	Steel	dr. (mm)	Tolerance (mm)	mm	Tolerance (mm)	mm	Tolerance (mm)	mm	Tolerance (mm)									DYNAMIC (C) ^{★1}	STATIC (Co)		
LMEKP08UU-SUS	LMEKP08-SUSA	8	+0.008 0	16	0 -0.008	25		32		5	5	24	25	3.4	6.5	3.2	12	260	400	4	44
LMEKP12UU-SUS	LMEKP12-SUSA	12		22	0 -0.009	32	0 -0.2	42		6	6	32	32	4.5	8	4.2	12	410	590	4	86
LMEKP16UU-SUS	LMEKP16-SUSA	16	+0.009 -0.001	26		36		46	0 -0.2	6	6	36	35	4.5	8	4.2	12	770	1,170	5	120
LMEKP20UU-SUS	LMEKP20-SUSA	20		32		45		54		8	8	43	42	5.5	9.5	5.2	15	860	1,370	5	184
LMEKP25UU-SUS	LMEKP25-SUSA	25	+0.011 -0.001	40	0 -0.011	58	0 -0.3	62		8	8	51	50	5.5	9.5	5.2	15	980	1,560	6	335
LMEKP30UU-SUS	LMEKP30-SUSA	30		47		68		76		10	10	62	60	6.6	11	6.5	15	1,560	2,740	6	545

★1 Dynamic load rating is based on the nominal life of 50km

★2 Based on the weight of resin retainer

★3 Main unit : mm

★4 1N ≒ 0.102kgf

LMEKP_L FLANGED LONG LINEAR BUSHING-SUS SERIES

● Drawing

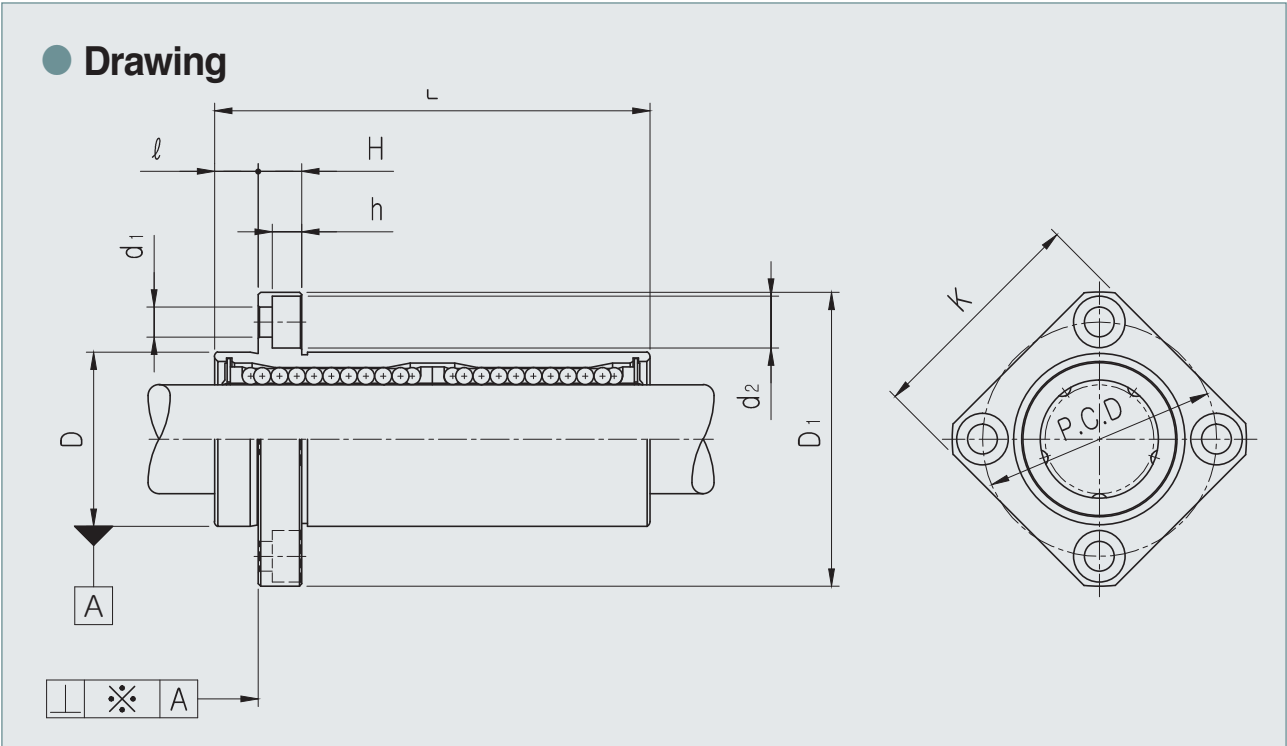

● Part Number Notation

LMEKP 20 L UU - SUS A

- European Standard Samick Square Pilot Flanged Linear Bushing
- Nominal Shaft Diameter
- Linear Bushing Long Type (for high load)
- Seal

Blank	No Seal
UU	Both Side Seal
U	One Side Seal

- Outer-sleeves : Stainless Steel
- BALL : Stainless Steel
- Retainer (material)

Blank	Resin Retainer(Standard)
A	Steel Retainer(High temperature)

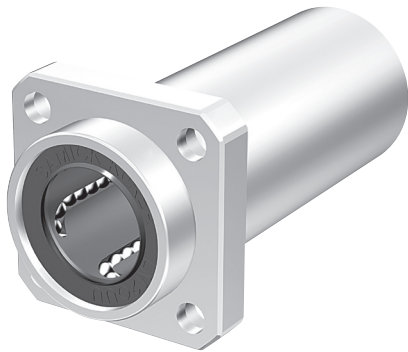

LMEKP_L FLANGED LONG LINEAR BUSHING-SUS SERIES

PART NUMBER		WORKING BORE DIAMETER		D		L		D ₁		ℓ	H	PCD	K	d ₁	d ₂	h	SQUARENESSE ※(μm)	BASIC LOAD RATING(N) ^{★4}		NO. OF BALL ROW	WEIGHT (gf) ^{★2}
Resin	Steel	dr. (mm)	Tolerance (mm)	mm	Tolerance (mm)	mm	Tolerance (mm)	mm	Tolerance (mm)									DYNAMIC (C) ^{★1}	STATIC (Co)		
LMEKP08LUU-SUS	LMEKP08L-SUSA	8	+0.009 -0.001	16	0 -0.009	45		32		5	5	24	25	3.4	6.5	3.2	15	430	780	4	53
LMEKP12LUU-SUS	LMEKP12L-SUSA	12		22	0 -0.011	57	0 -0.3	42		6	6	32	32	4.5	8	4.2	15	650	1,200	4	100
LMEKP16LUU-SUS	LMEKP16L-SUSA	16	+0.011 -0.001	26		70		46	0 -0.2	6	6	36	35	4.5	8	4.2	15	1,230	2,350	5	187
LMEKP20LUU-SUS	LMEKP20L-SUSA	20		32		80		54		8	8	43	42	5.5	9.5	5.2	17	1,400	2,750	5	260
LMEKP25LUU-SUS	LMEKP25L-SUSA	25	+0.013 -0.002	40	0 -0.013	112	0 -0.4	62		8	8	51	50	5.5	9.5	5.2	17	1,560	3,140	6	515
LMEKP30LUU-SUS	LMEKP30L-SUSA	30		47		123		76		10	10	62	60	6.6	11	6.5	17	2,490	5,490	6	655

★1 Dynamic load rating is based on the nominal life of 50km

★2 Based on the weight of resin retainer

★3 Main unit : mm

★4 1N ≒ 0.102kgf

LMEFM FLANGED LONG LINEAR BUSHING-SUS SERIES

● Drawing

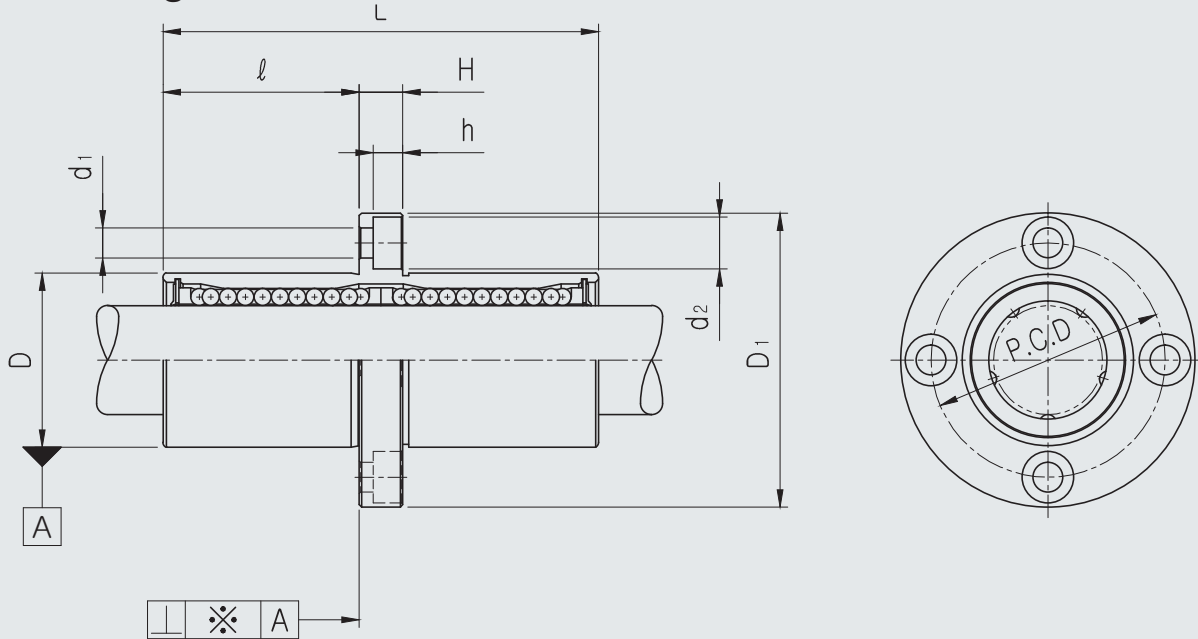

● Part Number Notation

LMEFM 20 UU - SUS A

- European Standard Samick Circular Middle Flanged Linear Bushing
- Nominal Shaft Diameter
- Seal

Blank	No Seal
UU	Both Side Seal
U	One Side Seal

- Outer-sleeves : Stainless Steel
- BALL : Stainless Steel
- Retainer (material)

Blank	Resin Retainer(Standard)
A	Steel Retainer(High temperature)



LMEFM FLANGED LONG LINEAR BUSHING-SUS SERIES

PART NUMBER		WORKING BORE DIAMETER		D		L		D ₁		ℓ	H	PCD	d ₁	d ₂	h	SQUAR ENESS ※(μm)	BASIC LOAD RATING(N) ^{★4}		NO. OF BALL ROW	WEIGHT (gf) ^{★2}
Resin	Steel	dr. (mm)	Tolerance (mm)	mm	Tolerance (mm)	mm	Tolerance (mm)	mm	Tolerance (mm)							DYNAMIC (C) ^{★1}	STATIC (Co)			
LMEFM08UU-SUS	LMEFM08-SUSA	8	+0.009 -0.001	16	0 -0.009	45	0 -0.3	32	0 -0.2	20	5	24	3.4	6.5	3.2	15	430	780	4	53
LMEFM12UU-SUS	LMEFM12-SUSA	12		22	0 -0.011	57		42		25.5	6	32	4.5	8	4.2	15	650	1,200	4	100
LMEFM16UU-SUS	LMEFM16-SUSA	16	+0.011 -0.001	26	0 -0.013	70	46	32		6	36	4.5	8	4.2	15	1,230	2,350	5	187	
LMEFM20UU-SUS	LMEFM20-SUSA	20		32		80	54	36		8	43	5.5	9.5	5.2	17	1,400	2,750	5	260	
LMEFM25UU-SUS	LMEFM25-SUSA	25	+0.013 -0.002	40	0 -0.013	112	62	52		8	51	5.5	9.5	5.2	17	1,560	3,140	6	515	
LMEFM30UU-SUS	LMEFM30-SUSA	30		47	123	76	56.5	10		62	6.6	11	6.5	17	2,940	5,490	6	655		

★1 Dynamic load rating is based on the nominal life of 50km

★2 Based on the weight of resin retainer

★3 Main unit : mm

★4 1N ≒ 0.102kgf

LMEKM FLANGED LONG LINEAR BUSHING-SUS SERIES

● Drawing

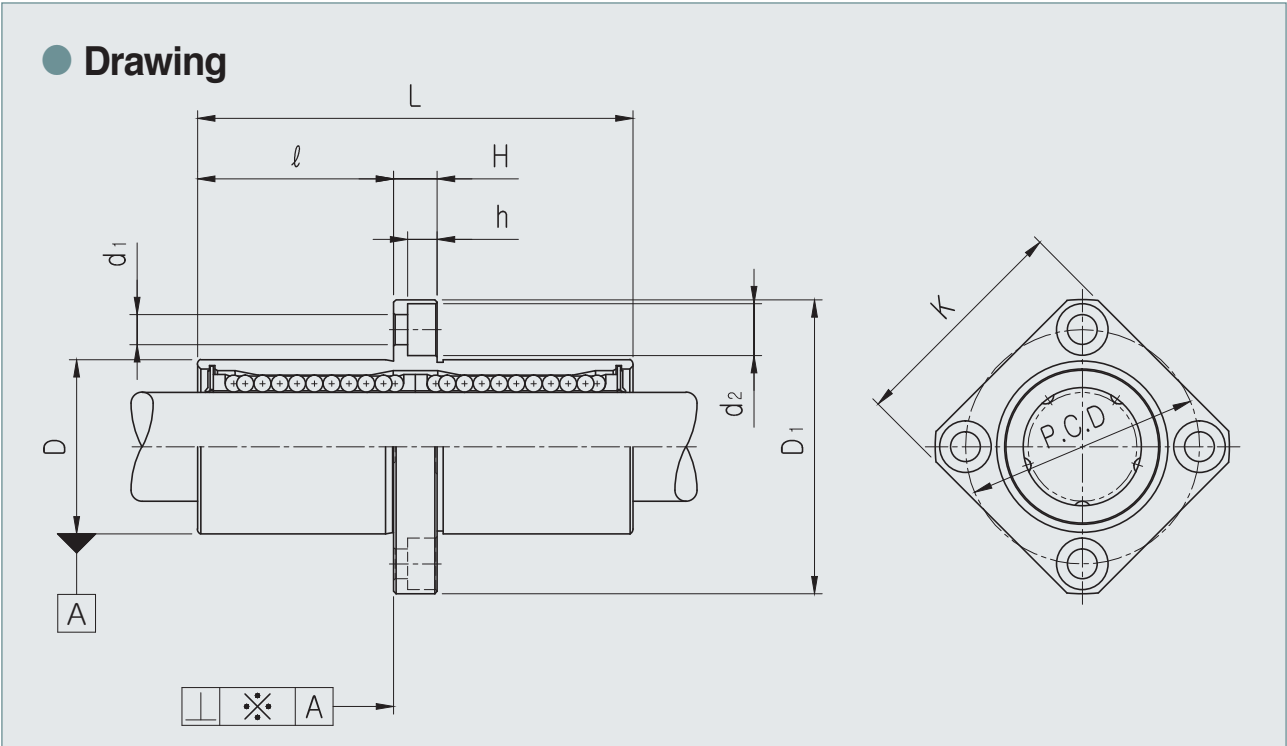

● Part Number Notation

LMEKM 20 UU - SUS A

- European Standard Samick Square Middle Flanged Linear Bushing
- Nominal Shaft Diameter
- Seal

Blank	No Seal
UU	Both Side Seal
U	One Side Seal

- Outer-sleeves : Stainless Steel
- BALL : Stainless Steel
- Retainer (material)

Blank	Resin Retainer(Standard)
A	Steel Retainer(High temperature)

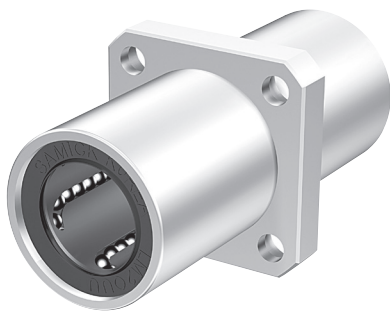

LMEKM FLANGED LONG LINEAR BUSHING-SUS SERIES

PART NUMBER		WORKING BORE DIAMETER		D		L		D ₁		ℓ	H	PCD	K	d ₁	d ₂	h	SQUAR ENESS ※(μm)	BASIC LOAD RATING(N) ^{★4}		NO. OF BALL ROW	WEIGHT (gf) ^{★2}
Resin	Steel	dr. (mm)	Tolerance (mm)	mm	Tolerance (mm)	mm	Tolerance (mm)	mm	Tolerance (mm)									DYNAMIC (C) ^{★1}	STATIC (Co)		
LMEKM08UU-SUS	LMEKM08-SUSA	8	+0.009 -0.001	16	0 -0.009	45		32		20	5	24	25	3.4	6.5	3.2	15	430	780	4	53
LMEKM12UU-SUS	LMEKM12-SUSA	12		22	0 -0.011	57	0 -0.3	42		25.5	6	32	32	4.5	8	4.2	15	650	1,200	4	100
LMEKM16UU-SUS	LMEKM16-SUSA	16	+0.011 -0.001	26		70		46	0 -0.2	32	6	36	35	4.5	8	4.2	15	1,230	2,350	5	187
LMEKM20UU-SUS	LMEKM20-SUSA	20		32		80		54		36	8	43	42	5.5	9.5	5.2	17	1,400	2,750	5	260
LMEKM25UU-SUS	LMEKM25-SUSA	25	+0.013 -0.002	40	0 -0.013	112	0 -0.4	62		52	8	51	50	5.5	9.5	5.2	17	1,560	3,140	6	515
LMEKM30UU-SUS	LMEKM30-SUSA	30		47		123		76		56.5	10	62	60	6.6	11	6.5	17	2,490	5,490	6	655

★1 Dynamic load rating is based on the nominal life of 50km

★2 Based on the weight of resin retainer

★3 Main unit : mm

★4 1N ≒ 0.102kgf

247

**SUS SERIES ALUMINUM CASE UNIT
(SC, SCE, SCB, SLB-SUS)**

SC ALUMINUM CASE UNIT-SUS SERIES

● Drawing

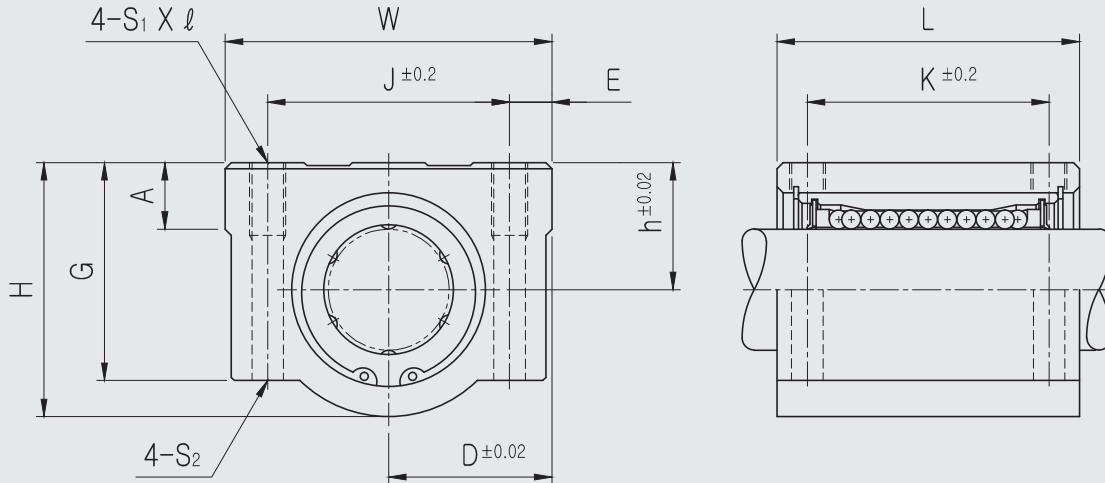

● Part Number Notation

SC 20 UU N - SUS A



- Aluminum Case Unit
- Nominal Shaft Diameter
- Seal

Blank	No Seal
UU	Both Side Seal
U	One Side Seal

- New type
- Outer-sleeves : Stainless Steel
- BALL : Stainless Steel
- Retainer (material)

Blank	Resin Retainer(Standard)
A	Steel Retainer(High temperature)

SC ALUMINUM CASE UNIT-SUS SERIES

PART NUMBER		L/B	h	D	W	H	G	A	J	E	S ₁ ×ℓ	S ₂	K	L	BASIC LOAD RATING(N) ^{★1}		WEIGHT (gf) ^{★2}
Resin	Steel														DYNAMIC (C) ^{★1}	STATIC (Co)	
SC08UU-SUS	SC08-SUSA	LM08UU-SUS	11	17	34	22	18	6	24	5	M4×8	Ø3.4	18	30	260	400	56
SC10UU-SUS	SC10-SUSA	LM10UU-SUS	13	20	40	26	21	8	28	6	M5×12	Ø4.3	21	35	370	540	90
SC12UU-SUS	SC12-SUSA	LM12UU-SUS	15	22	44	30	24.5	8	33	5.5	M5×12	Ø4.3	26	39	410	590	112
SC12UUN-SUS	SC12N-SUSA	LM12UU-SUS	15	21	42	28	24	7.4	30.5	5.75	M5×12	Ø4.3	26	36	410	590	112
SC13UU-SUS	SC13-SUSA	LM13UU-SUS	15	22	44	30	24.5	8	33	5.5	M5×12	Ø4.3	26	39	500	770	123
SC16UU-SUS	SC16-SUSA	LM16UU-SUS	19	25	50	38.5	32.5	9	36	7	M5×12	Ø4.3	34	44	770	1,170	189
SC20UU-SUS	SC20-SUSA	LM20UU-SUS	21	27	54	41	35	11	40	7	M6×12	Ø5.2	40	50	860	1,370	237
SC25UU-SUS	SC25-SUSA	LM25UU-SUS	26	38	76	51.5	41	12	54	11	M8×18	Ø6.8	50	67	980	1,560	555
SC30UU-SUS	SC30-SUSA	LM30UU-SUS	30	39	78	59.5	49	15	58	10	M8×18	Ø6.8	58	72	1,560	2,740	685

★1 Dynamic load rating is based on the nominal life of 50km

★2 Based on the weight of resin retainer

★3 Main unit : mm

★4 1N ≒ 0.102kgf

SCW ALUMINUM CASE UNIT LONG-SUS SERIES

● Drawing

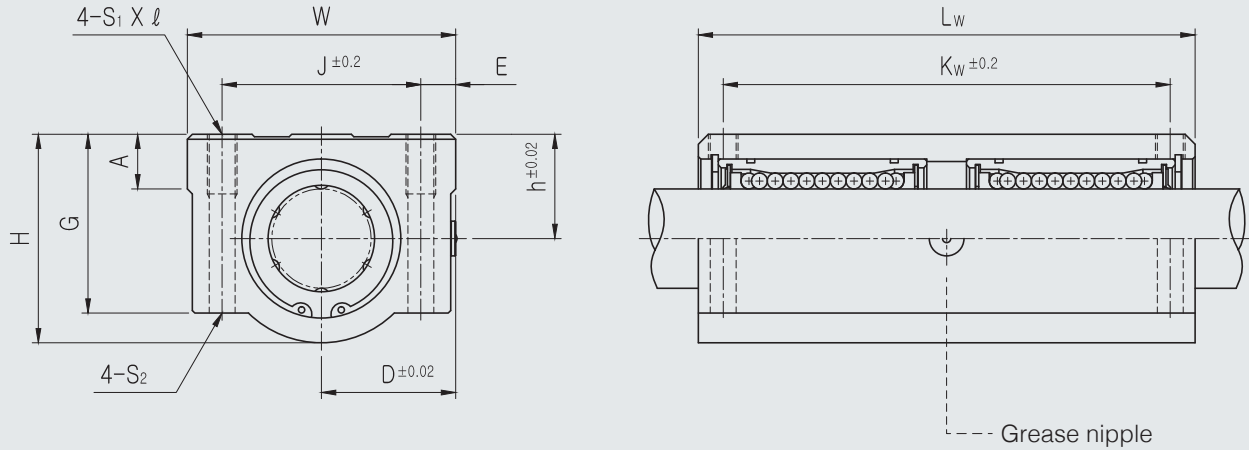

● Part Number Notation

SC 20 W UU - SUS A



- Aluminum Case Unit
- Nominal Shaft Diameter
- Linear Bushing Long Type (for high load)
- Seal

Blank	No Seal
UU	Both Side Seal
U	One Side Seal

- Outer-sleeves : Stainless Steel
- BALL : Stainless Steel
- Retainer (material)

Blank	Resin Retainer(Standard)
A	Steel Retainer(High temperature)

SCW ALUMINUM CASE UNIT LONG-SUS SERIES

PART NUMBER		L/B	h	D	W	H	G	A	J	E	S ₁ ×ℓ	S ₂	K _w	L _w	BASIC LOAD RATING(N) ^{★4}		WEIGHT (gf) ^{★2}
Resin	Steel														DYNAMIC (C) ^{★1}	STATIC (C ₀)	
SC08WUU-SUS	SC08W-SUSA	LM08U-SUS×2	11	17	34	22	18	6	24	5	M4×8	Ø3.4	42	58	410	800	94
SC10WUU-SUS	SC10W-SUSA	LM10U-SUS×2	13	20	40	26	21	8	28	6	M5×10	Ø4.3	46	68	590	1,080	147
SC12WUU-SUS	SC12W-SUSA	LM12U-SUS×2	15	22	44	30	24.5	8	33	5.5	M5×10	Ø4.3	64	77	650	1,180	220
SC13WUU-SUS	SC13W-SUSA	LM13U-SUS×2	15	22	44	30	24.5	8	33	5.5	M5×10	Ø4.3	64	77	800	1,540	245
SC16WUU-SUS	SC16W-SUSA	LM16U-SUS×2	19	25	50	38.5	32.5	9	36	7	M5×12	Ø4.3	79	89	1,230	2,340	376
SC20WUU-SUS	SC20W-SUSA	LM20U-SUS×2	21	27	54	41	35	11	40	7	M6×12	Ø5.2	90	100	1,370	2,740	476
SC25WUU-SUS	SC25W-SUSA	LM25U-SUS×2	26	38	76	51.5	41	12	54	11	M8×18	Ø6.8	119	136	1,560	3,120	1,115
SC30WUU-SUS	SC30W-SUSA	LM30U-SUS×2	30	39	78	59.5	49	15	58	10	M8×18	Ø6.8	132	146	2,490	5,480	1,375

★1 Dynamic load rating is based on the nominal life of 50km

★2 Based on the weight of resin retainer

★3 Main unit : mm

★4 1N ≒ 0.102kgf

SCW_N ALUMINUM CASE UNIT LONG-SUS SERIES

● Drawing

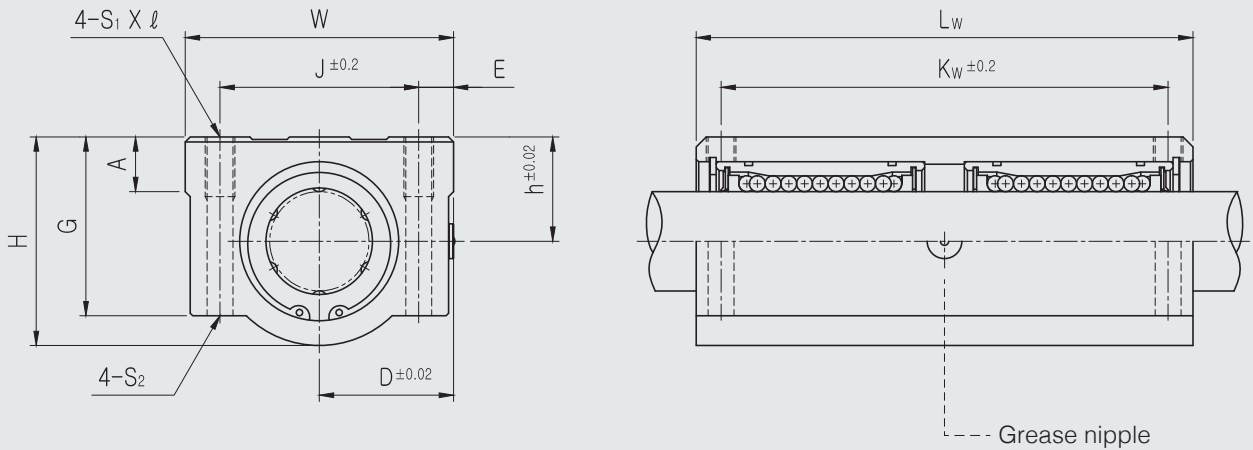

● Part Number Notation

SC 20 W UU N - SUS A



- Aluminum Case Unit
- Nominal Shaft Diameter
- Linear Bushing Long Type (for high load)
- Seal

Blank	No Seal
UU	Both Side Seal
U	One Side Seal

- New type
- Outer-sleeves : Stainless Steel
- BALL : Stainless Steel
- Retainer (material)

Blank	Resin Retainer(Standard)
A	Steel Retainer(High temperature)

SCW_N ALUMINUM CASE UNIT LONG-SUS SERIES

PART NUMBER		L/B	h	D	W	H	G	A	J	E	S ₁ × <i>l</i>	S ₂	K _w	L _w	BASIC LOAD RATING(N) ^{*4}		WEIGHT (g) ^{*2}
Resin	Steel														DYNAMIC (C) ^{*1}	STATIC (C ₀)	
SC08WUUN-SUS	SC08WN-SUSA	LM08U-SUS×2	11	17	34	22	18	6	24	5	M4×8	Ø3.4	42	58	410	800	94
SC10WUUN-SUS	SC10WN-SUSA	LM10U-SUS×2	13	20	40	26	21	8	28	6	M5×12	Ø4.3	46	68	590	1,080	147
SC12WUUN-SUS	SC12WN-SUSA	LM12U-SUS×2	15	21	42	28	24	7.4	30.5	5.75	M5×12	Ø4.3	50	70	650	1,180	220
SC13WUUN-SUS	SC13WN-SUSA	LM13U-SUS×2	15	22	44	30	24.5	8	33	5.5	M5×12	Ø4.3	50	75	800	1,540	245
SC16WUUN-SUS	SC16WN-SUSA	LM16U-SUS×2	19	25	50	38.5	32.5	9	36	7	M5×12	Ø4.3	60	85	1,230	2,340	376
SC20WUUN-SUS	SC20WN-SUSA	LM20U-SUS×2	21	27	54	41	35	11	40	7	M6×12	Ø5.2	70	96	1,370	2,740	476
SC25WUUN-SUS	SC25WN-SUSA	LM25U-SUS×2	26	38	76	51.5	41	12	54	11	M8×18	Ø6.8	100	130	1,560	3,120	1,115
SC30WUUN-SUS	SC30WN-SUSA	LM30U-SUS×2	30	39	78	59.5	49	15	58	10	M8×18	Ø6.8	110	140	2,490	5,480	1,375

★1 Dynamic load rating is based on the nominal life of 50km

★2 Based on the weight of resin retainer

★3 Main unit : mm

★4 1N ≒ 0.102kgf

SCV ALUMINUM CASE UNIT-SUS SERIES

● Drawing

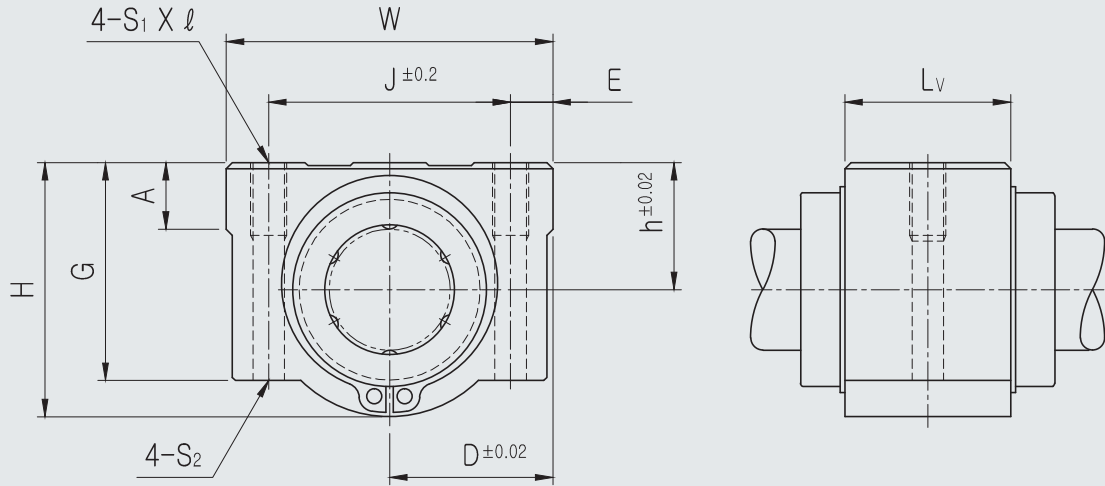

● Part Number Notation

SC 20 V UU N - SUS A

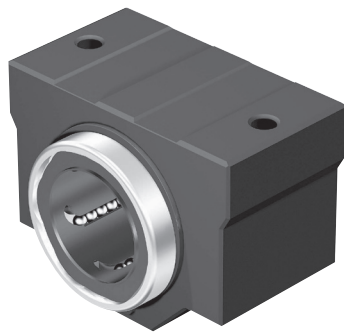

- Aluminum Case Unit
- Nominal Shaft Diameter
- Compact type
- Seal

Blank	No Seal
UU	Both Side Seal
U	One Side Seal

- New type
- Outer-sleeves : Stainless Steel
- BALL : Stainless Steel
- Retainer (material)

Blank	Resin Retainer(Standard)
A	Steel Retainer(High temperature)

SCV ALUMINUM CASE UNIT-SUS SERIES

PART NUMBER		L/B	h	D	W	H	G	A	J	E	S ₁ ×l	S ₂	L _w	BASIC LOAD RATING(N) ^{★4}		WEIGHT (gf) ^{★2}
Resin	Steel													DYNAMIC (C) ^{★1}	STATIC (Co)	
SC08VUU-SUS	SC08V-SUSA	LM08UU-SUS	11	17	34	22	18	6	24	5	M4×8	Ø3.4	15.4	260	400	36
SC10VUU-SUS	SC10V-SUSA	LM10UU-SUS	13	20	40	26	21	8	28	6	M5×10	Ø4.3	19.5	370	540	63
SC12VUU-SUS	SC12V-SUSA	LM12UU-SUS	15	22	44	30	24.5	8	33	5.5	M5×12	Ø4.3	20.5	410	590	74
SC12VUUN-SUS	SC12VN-SUSA	LM12UU-SUS	15	21	42	28	24	7.4	30.5	5.75	M5×12	Ø4.3	20.5	410	590	74
SC13VUU-SUS	SC13V-SUSA	LM13UU-SUS	15	22	44	30	24.5	8	33	5.5	M5×12	Ø4.3	20.5	500	770	85
SC16VUU-SUS	SC16V-SUSA	LM16UU-SUS	19	25	50	38.5	32.5	9	36	7	M5×12	Ø4.3	23.5	770	1,170	132
SC20VUU-SUS	SC20V-SUSA	LM20UU-SUS	21	27	54	41	35	11	40	7	M6×12	Ø5.2	27.4	860	1,370	170
SC25VUU-SUS	SC25V-SUSA	LM25UU-SUS	26	38	76	51.5	41	12	54	11	M8×18	Ø6.8	37.4	980	1,560	405
SC30VUU-SUS	SC30V-SUSA	LM30UU-SUS	30	39	78	59.5	49	15	58	10	M8×18	Ø6.8	40.9	1,560	2,740	495

★1 Dynamic load rating is based on the nominal life of 50km

★2 Based on the weight of resin retainer

★3 Main unit : mm

★4 1N ≒ 0.102kgf

SCJ ADJUSTABLE ALUMINUM CASE UNIT-SUS SERIES

● Drawing

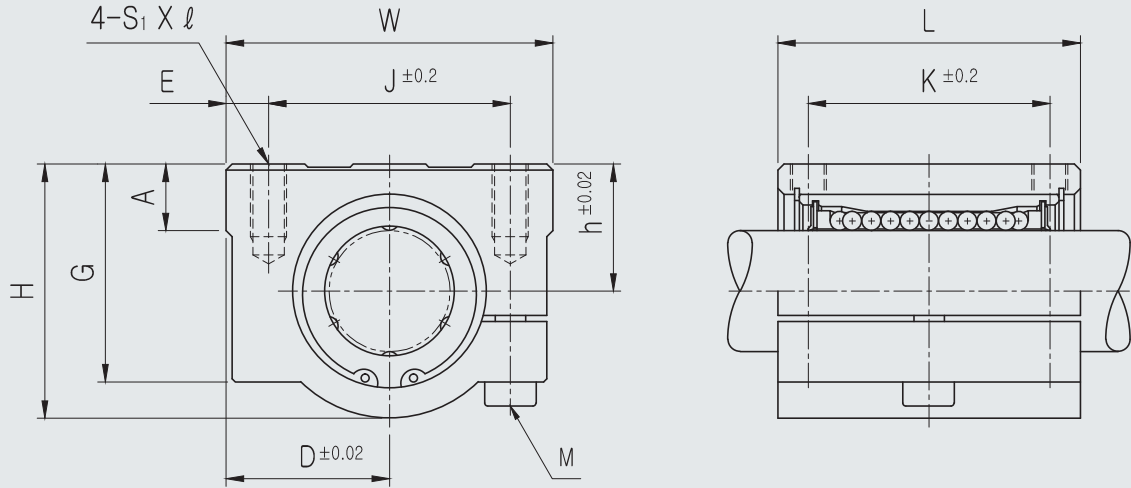

● Part Number Notation

SCJ 20 UU - SUS A

- Aluminum Case Unit(Adjustable type)
- Nominal Shaft Diameter
- Seal

Blank	No Seal
UU	Both Side Seal
U	One Side Seal

- Outer-sleeves : Stainless Steel
- BALL : Stainless Steel
- Retainer (material)

Blank	Resin Retainer(Standard)
A	Steel Retainer(High temperature)

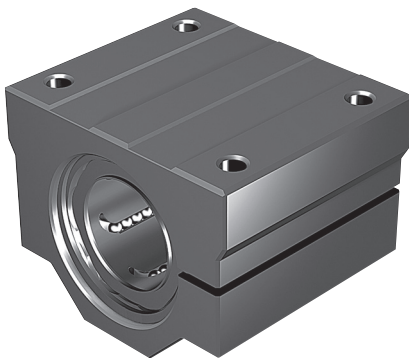

SCJ ADJUSTABLE ALUMINUM CASE UNIT-SUS SERIES

PART NUMBER		L/B	h	D	W	H	G	A	J	E	S _i ×l	K	L	M	BASIC LOAD RATING(N) ^{*4}		OUTER DIAMETER	WEIGHT (gf) ^{*2}
Resin	Steel														DYNAMIC (C) ^{*1}	STATIC (Co)		
SCJ10UU-SUS	SCJ10-SUSA	LM10UUAJ-SUS	13	20	40	26	21	8	28	6	M5×12	21	35	M4	370	540	Ø10	90
SCJ12UU-SUS	SCJ12-SUSA	LM12UUAJ-SUS	15	21	42	28	24	7.4	30.5	5.75	M5×12	26	36	M4	410	590	Ø12	112
SCJ13UU-SUS	SCJ13-SUSA	LM13UUAJ-SUS	15	22	44	30	24.5	8	33	5.5	M5×12	26	39	M4	500	770	Ø13	123
SCJ16UU-SUS	SCJ16-SUSA	LM16UUAJ-SUS	19	25	50	38.5	32.5	9	36	7	M5×12	34	44	M4	770	1,170	Ø16	189
SCJ20UU-SUS	SCJ20-SUSA	LM20UUAJ-SUS	21	27	54	41	35	11	40	7	M6×12	40	50	M5	860	1,370	Ø20	237
SCJ25UU-SUS	SCJ25-SUSA	LM25UUAJ-SUS	26	38	76	51.5	41	12	54	11	M8×18	50	67	M6	980	1,560	Ø25	555
SCJ30UU-SUS	SCJ30-SUSA	LM30UUAJ-SUS	30	39	78	59.5	49	15	58	10	M8×18	58	72	M6	1,560	2,740	Ø30	685

★1 Dynamic load rating is based on the nominal life of 50km

★2 Based on the weight of resin retainer

★3 Main unit : mm

★4 1N ≒ 0.102kgf

SBR ALUMINUM CASE UNIT OPEN-SUS SERIES

● Drawing

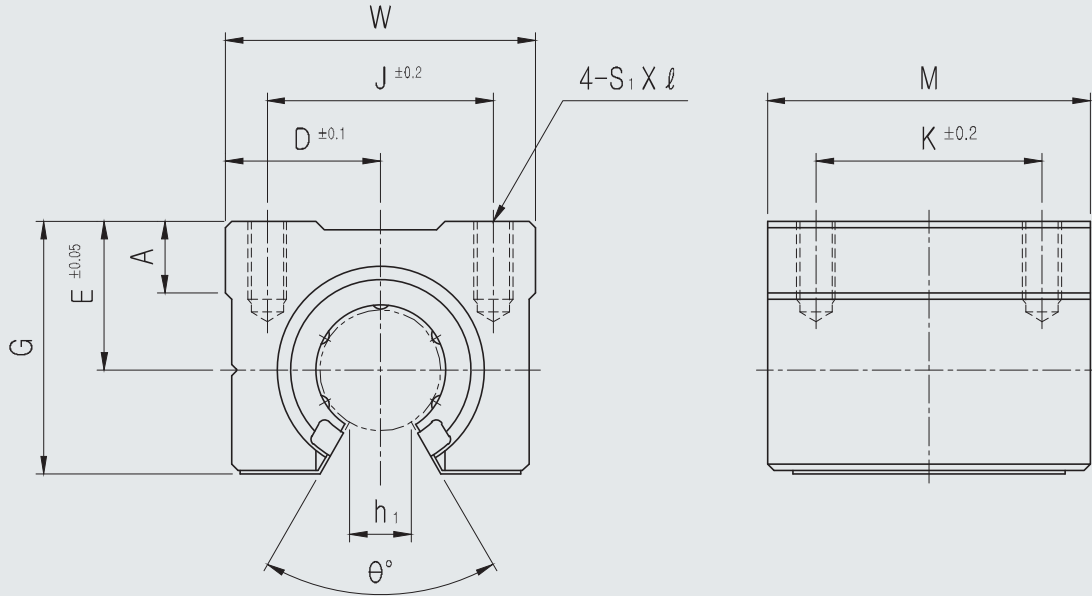

● Part Number Notation

SBR 20 UU - SUS

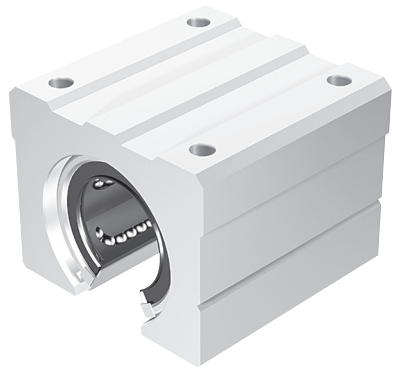
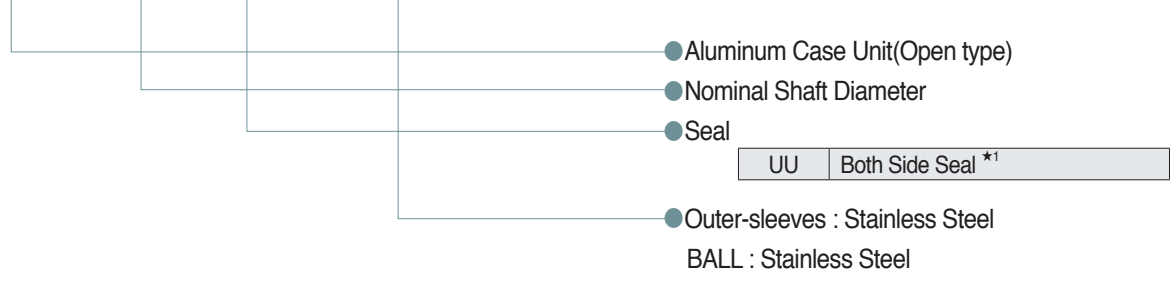

* ★1 UU type only available.
 No seal type & One side seal type not available.
 ★ Resin retainer only applicable

SBR ALUMINUM CASE UNIT OPEN-SUS SERIES

PART NUMBER	L/B	D	W	G	θ	A	M	S ₁ × l	h ₁	E	J	K	BASIC LOAD RATING(N) ^{*4}		WEIGHT (g) ^{*2}
													DYNAMIC (C) ^{*1}	STATIC (Co)	
SBR16UU-SUS	LM16UUOP-SUS	22.5	45	33	80°	9	45	M5×12	11	20	32	30	770	1,170	150
SBR20UU-SUS	LM20UUOP-SUS	24	48	39	60°	11	50	M6×12	11	23	35	35	860	1,370	200
SBR25UU-SUS	LM25UUOP-SUS	30	60	47	50°	14	65	M6×12	12	27	40	40	980	1,560	450
SBR30UU-SUS	LM30UUOP-SUS	35	70	56	50°	15	70	M8×18	15	33	50	50	1,560	2,740	630

★1 Dynamic load rating is based on the nominal life of 50km

★2 Based on the weight of resin retainer

★3 Main unit : mm

★4 1N ≒ 0.102kgf

TBR ALUMINUM CASE UNIT OPEN

● Drawing

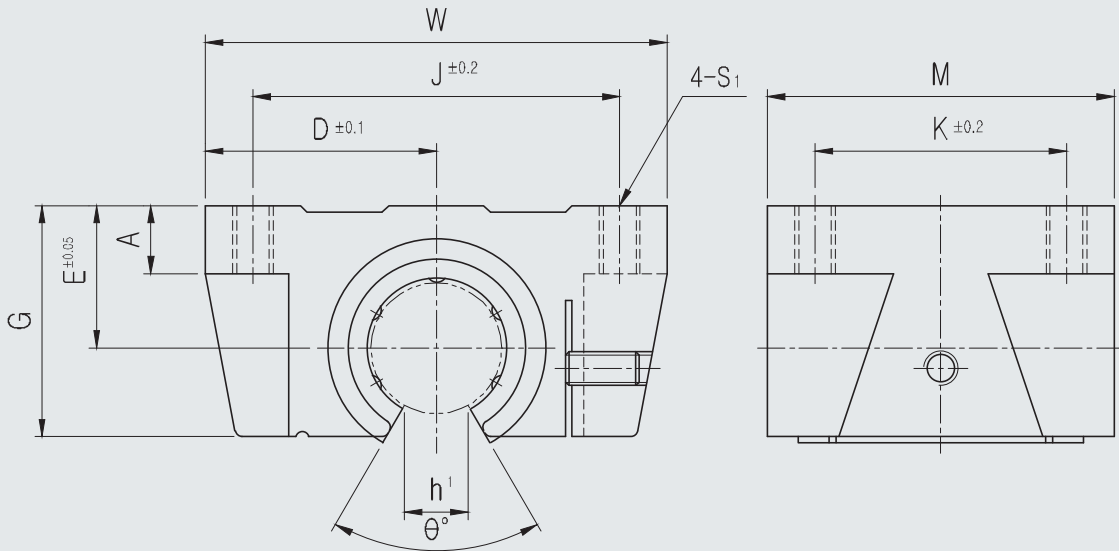

● Part Number Notation

TBR 20 UU - SUS

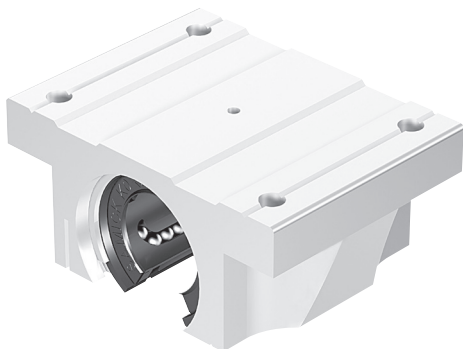
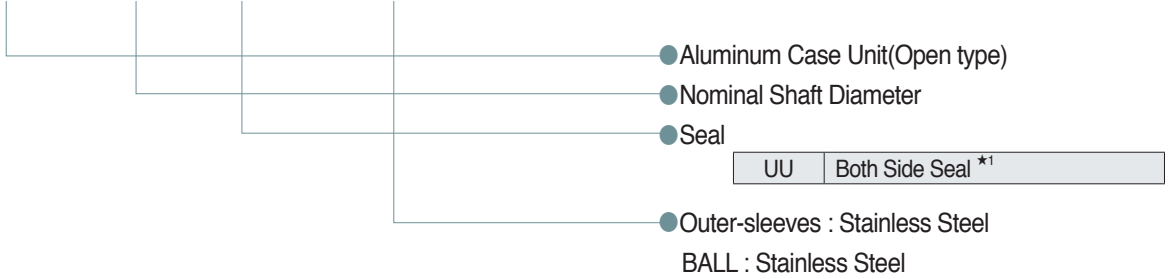

※ ★1 UU type only available.
 No seal type & One side seal type not available.
 ★ Resin retainer only applicable

TBR ALUMINUM CASE UNIT OPEN

PART NUMBER	L/B	D	W	G	θ	A	M	S ₁	h ₁	E	J	K	BASIC LOAD RATING(N) ^{*4}		WEIGHT (gf) ^{*2}
													DYNAMIC (C) ^{*1}	STATIC (Co)	
TBR16UU-SUS	LM16UUOP-SUS	31	62	26	80°	8	42	M5	11	18	50	30	770	1,170	180
TBR20UU-SUS	LM20UUOP-SUS	34	68	31	60°	10	51	M6	11	21	54	37	860	1,370	300
TBR25UU-SUS	LM25UUOP-SUS	41	82	41	50°	12	65	M8	12	28	65	50	980	1,560	600
TBR30UU-SUS	LM30UUOP-SUS	45.5	91	48	50°	12	75	M8	15	34	75	60	1,560	2,740	900

★1 Dynamic load rating is based on the nominal life of 50km

★2 Based on the weight of resin retainer

★3 Main unit : mm

★4 1N ≒ 0.102kgf

SCE ALUMINUM CASE UNIT-SUS SERIES

● Drawing

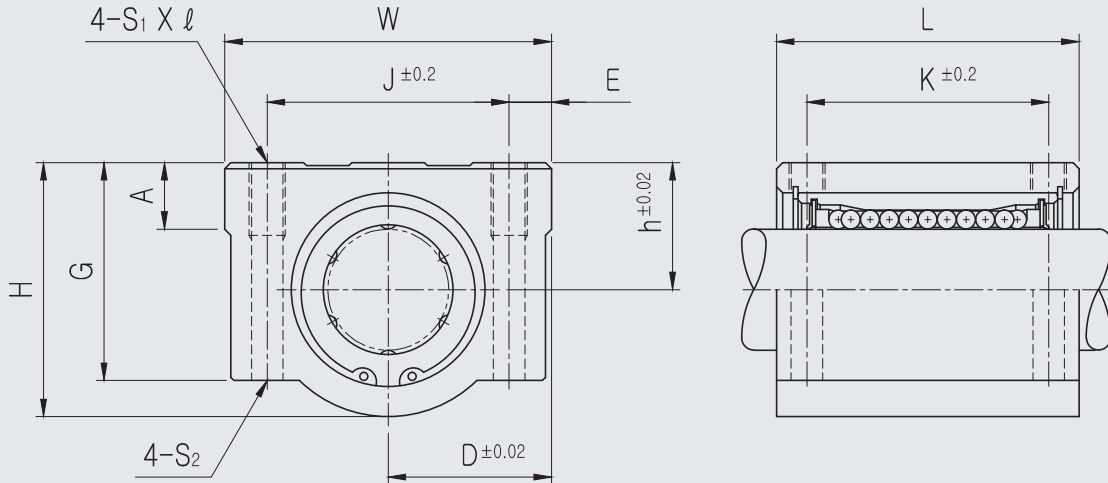

● Part Number Notation

SCE 20 UU - SUS A

- European Standard Aluminum Case Unit
- Nominal Shaft Diameter
- Seal

Blank	No Seal
UU	Both Side Seal
U	One Side Seal

- Outer-sleeves : Stainless Steel
- BALL : Stainless Steel
- Retainer (material)

Blank	Resin Retainer(Standard)
A	Steel Retainer(High temperature)



SCE ALUMINUM CASE UNIT-SUS SERIES

PART NUMBER		L/B	h	D	W	H	G	A	J	E	S ₁ × <i>l</i>	S ₂	K	L	BASIC LOAD RATING(N) ^{★4}		WEIGHT (g) ^{★2}
Resin	Steel														DYNAMIC (C) ^{★1}	STATIC (Co)	
SCE08UU-SUS	SCE08-SUSA	LME08UU-SUS	11	17	34	22	18	6	24	5	M4×8	Ø3.4	18	30	260	400	60
SCE12UU-SUS	SCE12-SUSA	LME12UU-SUS	15	22	44	30	24.5	8	33	5.5	M5×10	Ø4.3	26	39	410	590	118
SCE16UU-SUS	SCE16-SUSA	LME16UU-SUS	19	25	50	38.5	32.5	9	36	7	M5×12	Ø4.3	34	44	770	1,170	180
SCE20UU-SUS	SCE20-SUSA	LME20UU-SUS	21	27	54	41	35	11	40	7	M6×12	Ø5.2	40	53	860	1,370	245
SCE25UU-SUS	SCE25-SUSA	LME25UU-SUS	26	38	76	51.5	41	12	54	11	M8×18	Ø6.8	50	67	980	1,560	550
SCE30UU-SUS	SCE30-SUSA	LME30UU-SUS	30	39	78	59.5	49	15	58	10	M8×18	Ø6.8	58	76	1,560	2,740	760

★1 Dynamic load rating is based on the nominal life of 50km

★2 Based on the weight of resin retainer

★3 Main unit : mm

★4 1N ≒ 0.102kgf

SCE_W ALUMINUM CASE UNIT LONG-SUS SERIES

● Drawing

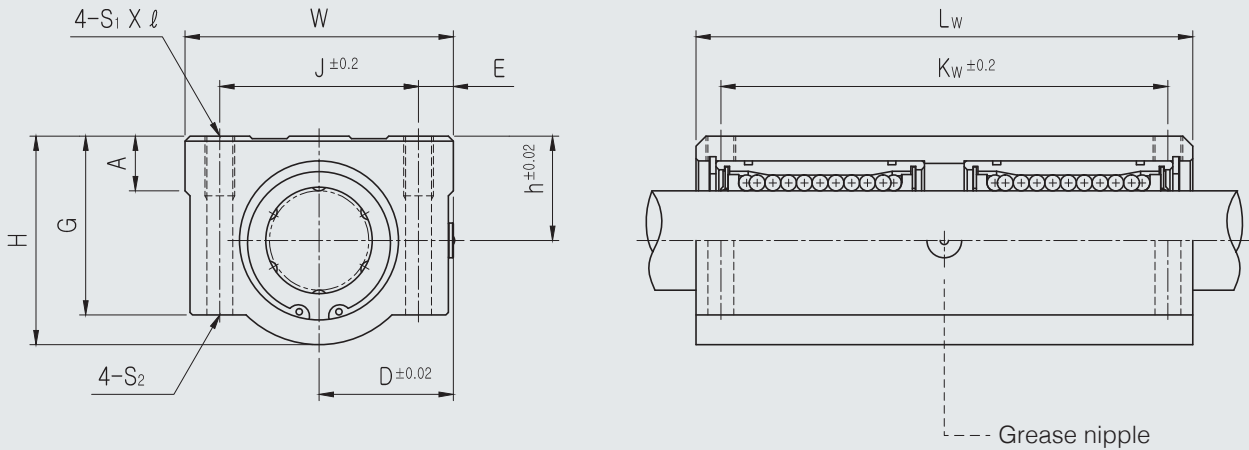

● Part Number Notation

SCE 20 W UU - SUS A

- Aluminum Case Unit
- Nominal Shaft Diameter
- Linear Bushing Long Type (for high load)
- Seal

Blank	No Seal
UU	Both Side Seal
U	One Side Seal

- Outer-sleeves : Stainless Steel
- BALL : Stainless Steel
- Retainer (material)

Blank	Resin Retainer(Standard)
A	Steel Retainer(High temperature)



SCE_W ALUMINUM CASE UNIT LONG-SUS SERIES

PART NUMBER		L/B	h	D	W	H	G	A	J	E	S ₁ × <i>l</i>	S ₂	K _w	L _w	BASIC LOAD RATING(N) ^{*4}		WEIGHT (gf) ^{*2}
Resin	Steel														DYNAMIC (C) ^{*1}	STATIC (C ₀)	
SCE08WUU-SUS	SCE08W-SUSA	LME08U-SUS×2	11	17	34	22	18	6	24	5	M4×8	Ø3.4	42	58	410	800	98
SCE12WUU-SUS	SCE12W-SUSA	LME12U-SUS×2	15	22	44	30	24.5	8	33	5.5	M5×10	Ø4.3	64	77	650	1,180	232
SCE16WUU-SUS	SCE16W-SUSA	LME16U-SUS×2	19	25	50	38.5	32.5	9	36	7	M5×12	Ø4.3	79	89	1,230	2,340	360
SCE20WUU-SUS	SCE20W-SUSA	LME20U-SUS×2	21	27	54	41	35	11	40	7	M6×12	Ø5.2	90	106	1,370	2,740	490
SCE25WUU-SUS	SCE25W-SUSA	LME25U-SUS×2	26	38	76	51.5	41	12	54	11	M8×18	Ø6.8	119	136	1,560	3,120	1,100
SCE30WUU-SUS	SCE30W-SUSA	LME30U-SUS×2	30	39	78	59.5	49	15	58	10	M8×18	Ø6.8	132	154	2,490	5,480	1,525

★1 Dynamic load rating is based on the nominal life of 50km

★2 Based on the weight of resin retainer

★3 Main unit : mm

★4 1N ≒ 0.102kgf

SCE_V ALUMINUM CASE UNIT-SUS SERIES

● Drawing

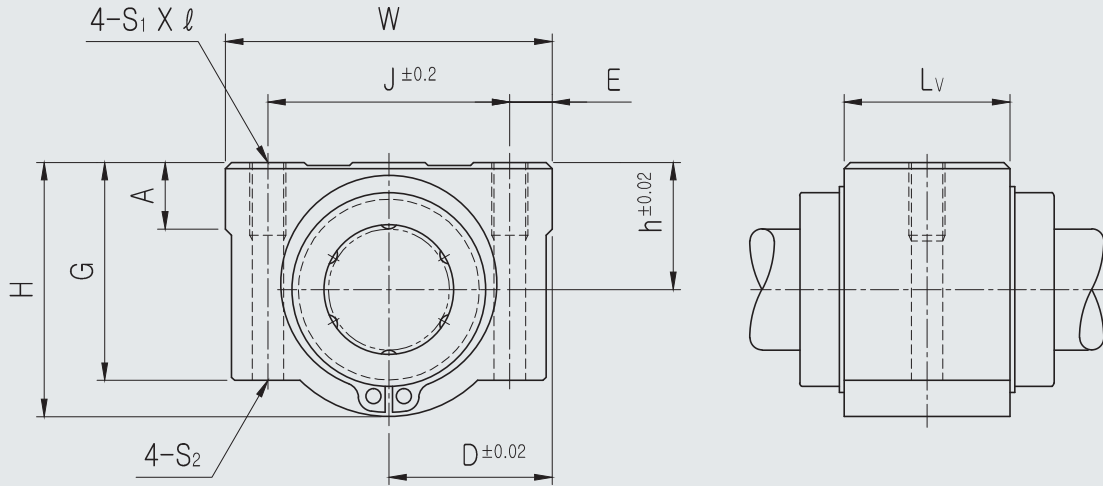

● Part Number Notation

SCE 20 V UU - SUS A

- European Standard Aluminum Case Unit
- Nominal Shaft Diameter
- Compact type
- Seal

Blank	No Seal
UU	Both Side Seal
U	One Side Seal

- Outer-sleeves : Stainless Steel
- BALL : Stainless Steel
- Retainer (material)

Blank	Resin Retainer(Standard)
A	Steel Retainer(High temperature)

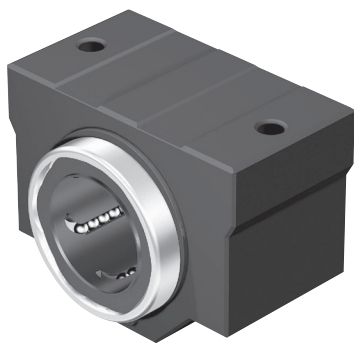

SCE_V ALUMINUM CASE UNIT-SUS SERIES

PART NUMBER		L/B	h	D	W	H	G	A	J	E	S ₁ × <i>l</i>	S ₂	L _w	BASIC LOAD RATING(N) ^{★4}		WEIGHT (gf) ^{★2}
Resin	Steel													DYNAMIC (C) ^{★1}	STATIC (Co)	
SCE08VUU-SUS	SCE08V-SUSA	LME08UU-SUS	11	17	34	22	18	6	24	5	M4×8	Ø3.4	14.4	260	400	40
SCE12VUU-SUS	SCE12V-SUSA	LME12UU-SUS	15	22	44	30	24.5	8	33	5.5	M5×10	Ø4.3	20.3	410	590	82
SCE16VUU-SUS	SCE16V-SUSA	LME16UU-SUS	19	25	50	38.5	32.5	9	36	7	M5×12	Ø4.3	22.3	770	1,170	122
SCE20VUU-SUS	SCE20V-SUSA	LME20UU-SUS	21	27	54	41	35	11	40	7	M6×12	Ø5.2	28.3	860	1,370	176
SCE25VUU-SUS	SCE25V-SUSA	LME25UU-SUS	26	38	76	51.5	41	12	54	11	M8×18	Ø6.8	40.4	980	1,560	400
SCE30VUU-SUS	SCE30V-SUSA	LME30UU-SUS	30	39	78	59.5	49	15	58	10	M8×18	Ø6.8	48.4	1,560	2,740	570

★1 Dynamic load rating is based on the nominal life of 50km

★2 Based on the weight of resin retainer

★3 Main unit : mm

★4 1N ≒ 0.102kgf

SCB ALUMINUM CASE UNIT-SUS SERIES

● Drawing

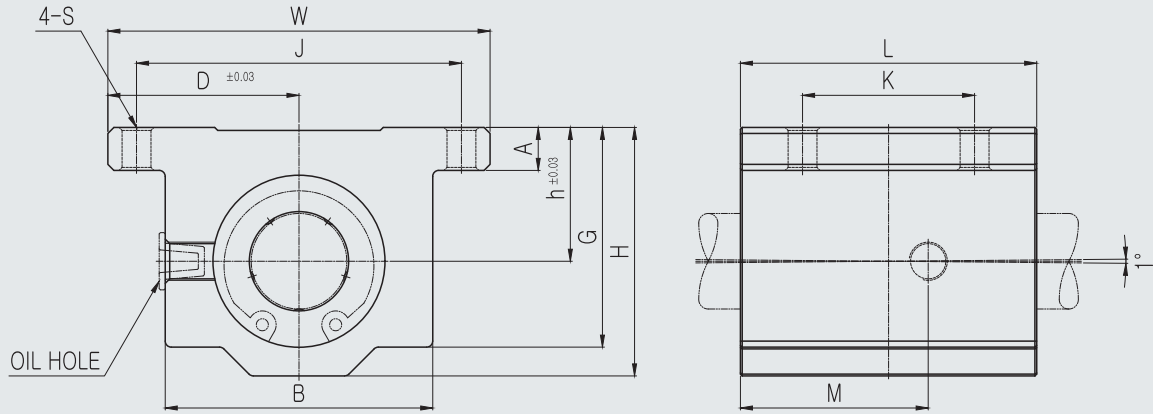

● Part Number Notation

SCB 20 UU - SUS

● Aluminum Case Unit
Self-Aligning Linear Bushing(inch type)

● Nominal Shaft Diameter

● Seal

Blank	No Seal
UU	Both Side Seal
U	One Side Seal

● Ball Plate & Ball

SUS	Ball Plate : Stainless steel
	Ball : Stainless steel



SCB ALUMINUM CASE UNIT-SUS SERIES

PART NUMBER	L/B	W	L	H	J	K	S	D	h	A	G	B	M	BASIC LOAD RATING(lbf)		WEIGHT (gf)
								±0.0012	±0.0012					DYNAMIC (C) ^{★2}	STATIC (Co)	
SCB04UU-SUS	LMBS04UU-SUS	1.63	1.19	0.81	1.312	0.750	0.16	0.8125	0.4370	0.19	0.75	1.00	0.80	60	49	0.089
SCB06UU-SUS	LMBS06UU-SUS	1.75	1.31	0.94	1.437	0.875	0.16	0.8750	0.5000	0.19	0.88	1.13	0.88	75	66	0.185
SCB08UU-SUS	LMBS08UU-SUS	2.00	1.69	1.25	1.688	1.000	0.16	1.0000	0.6870	0.25	1.13	1.38	1.10	195	190	0.240
SCB10UU-SUS	LMBS10UU-SUS	2.50	1.94	1.63	2.125	1.125	0.19	1.2500	0.8750	0.28	1.44	1.75	1.23	365	340	0.455
SCB12UU-SUS	LMBS12UU-SUS	2.75	2.06	1.75	2.375	1.250	0.19	1.3750	0.9370	0.31	1.56	1.88	1.35	505	430	0.550
SCB16UU-SUS	LMBS16UU-SUS	3.25	2.81	2.19	2.875	1.750	0.22	1.6250	1.1870	0.38	1.94	2.38	1.84	895	780	1.180
SCB20UU-SUS	LMBS20UU-SUS	4.00	3.63	2.81	3.500	2.000	0.22	2.0000	1.5000	0.44	2.50	3.00	2.31	1,320	1,270	2.350
SCB24UU-SUS	LMBS24UU-SUS	4.75	4.00	3.25	4.125	2.500	0.28	2.3750	1.7500	0.50	2.88	3.50	2.62	1,850	1,540	3.440
SCB32UU-SUS	LMBS32UU-SUS	6.00	5.00	4.06	5.250	3.250	0.41	3.0000	2.1250	0.63	3.63	4.50	3.35	2,735	2,580	6.810

★1 Dynamic load rating is based on the nominal life of 50km

★2 Main unit : inch

★3 1 lbf = 0.453kgf

SCB_OP OPEN ALUMINUM CASE UNIT-SUS SERIES

● Drawing

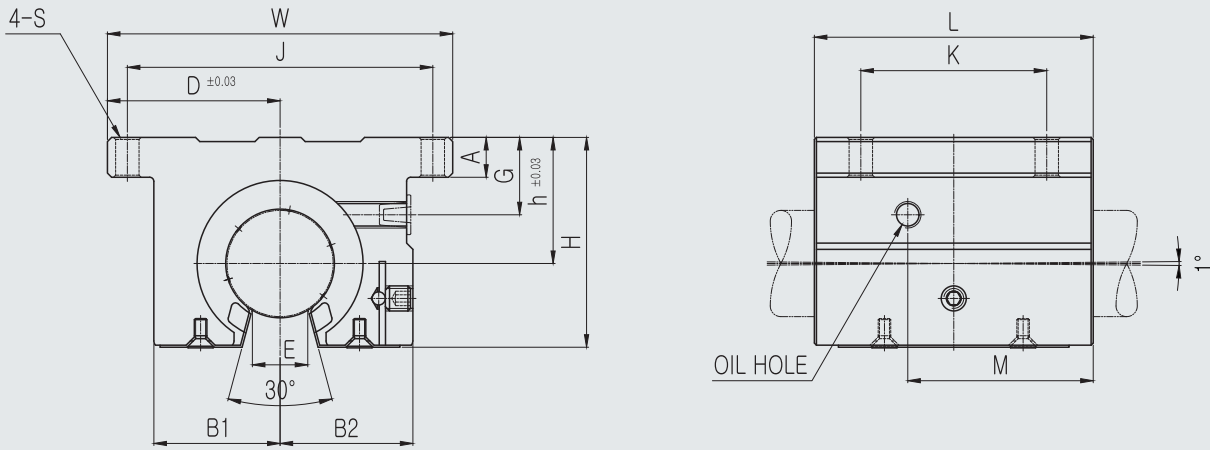

● Part Number Notation

SCB 20 UU OP - SUS

- Aluminum Case Unit
Self-Aligning Linear Bushing(inch type)
- Nominal Shaft Diameter
- Seal

Blank	No Seal
UU	Both Side Seal
U	One Side Seal

- Open type Linear Bushing
- Ball Plate & Ball

SUS	Ball Plate : Stainless steel
	Ball : Stainless steel



SCB_OP OPEN ALUMINUM CASE UNIT-SUS SERIES

PART NUMBER	L/B	W	H	L	J	K	S	D		h	A	B1	B2	M	G	E	BASIC LOAD RATING(lbf)		WEIGHT (gf)
								±0.0012	±0.0012								DYNAMIC (C) ^{*2}	STATIC (Co)	
SCB08UUOP-SUS	LMBS08UUOP-SUS	2.00	1.100	1.50	1.688	1.000	0.16	1.000	0.687	0.25	0.69	0.75	0.99	0.44	0.27	195	190	0.185	
SCB10UUOP-SUS	LMBS10UUOP-SUS	2.50	1.405	1.75	2.125	1.125	0.19	1.250	0.875	0.28	0.88	0.94	1.08	0.47	0.33	480	340	0.361	
SCB12UUOP-SUS	LMBS12UUOP-SUS	2.75	1.535	1.88	2.375	1.250	0.19	1.375	0.937	0.31	0.94	1.00	1.15	0.51	0.39	560	430	0.450	
SCB16UUOP-SUS	LMBS16UUOP-SUS	3.25	1.975	2.62	2.875	1.750	0.22	1.625	1.187	0.38	1.19	1.25	1.75	0.73	0.52	1,010	780	1.005	
SCB20UUOP-SUS	LMBS20UUOP-SUS	4.00	2.485	3.38	3.500	2.000	0.22	2.000	1.500	0.44	1.50	1.63	2.18	0.80	0.58	1,510	1,270	1.975	
SCB24UUOP-SUS	LMBS24UUOP-SUS	4.75	2.910	3.73	4.125	2.500	0.28	2.375	1.750	0.50	1.75	1.87	2.49	0.91	0.70	2,100	1,540	2.945	
SLB32UUOP-SUS	LMBS32UUOP-SUS	6.00	3.660	4.75	5.250	3.250	0.41	3.000	2.125	0.63	2.25	2.44	3.16	1.10	0.96	3,050	2,580	5.830	

★1 Dynamic load rating is based on the nominal life of 50km

★2 Main unit : inch

★3 1 lbf = 0.453kgf

SLB ALUMINUM CASE UNIT-SUS SERIES

● Drawing

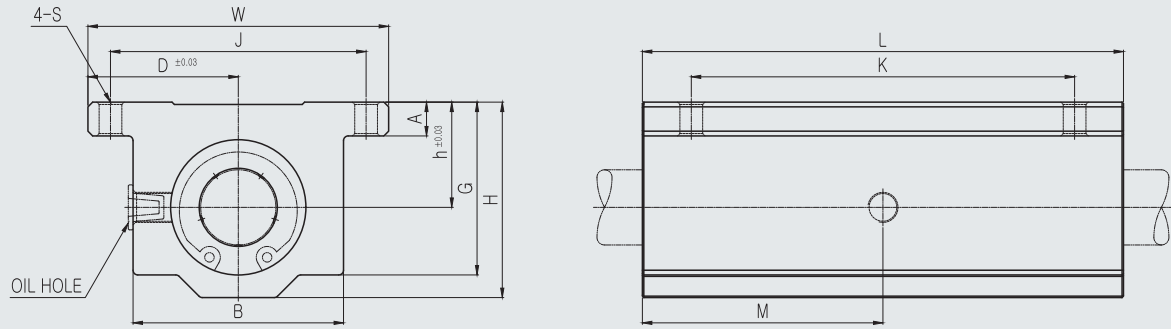

● Part Number Notation

SLB 20 UU - SUS

- Aluminum Case Unit
Self-Aligning Linear Bushing(inch type)
- Nominal Shaft Diameter
- Seal

Blank	No Seal
UU	Both Side Seal
U	One Side Seal

- Ball Plate & Ball

SUS	Ball Plate : Stainless steel
	Ball : Stainless steel

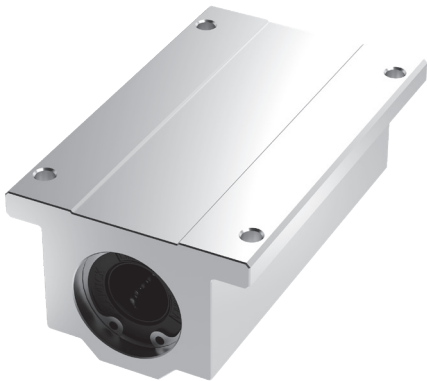

SLB ALUMINUM CASE UNIT-SUS SERIES

PART NUMBER	L/B	W	L	H	J	K	S	D	h	A	G	B	M	BASIC LOAD RATING(lbf)		WEIGHT (gf)
								±0.0012	±0.0012					DYNAMIC (C) ^{*2}	STATIC (Co)	
SLB04UU-SUS	LMBS04U-SUS x2	1.63	2.50	0.81	1.312	2.000	0.16	0.8125	0.4370	0.19	0.75	1.00	1.25	120	98	0.185
SLB06UU-SUS	LMBS06U-SUS x2	1.75	2.75	0.94	1.437	2.250	0.16	0.8750	0.5000	0.19	0.88	1.13	1.38	150	132	0.240
SLB08UU-SUS	LMBS08U-SUS x2	2.00	3.50	1.25	1.688	2.500	0.16	1.0000	0.6870	0.25	1.13	1.38	1.75	390	380	0.500
SLB10UU-SUS	LMBS10U-SUS x2	2.50	4.00	1.63	2.125	3.000	0.19	1.2500	0.8750	0.28	1.44	1.74	2.00	730	680	0.990
SLB12UU-SUS	LMBS12U-SUS x2	2.75	4.50	1.75	2.375	3.500	0.19	1.3750	0.9370	0.31	1.56	1.88	2.25	1,010	860	1.180
SLB16UU-SUS	LMBS16U-SUS x2"	3.25	6.00	2.19	2.875	4.500	0.22	1.6250	1.1870	0.38	1.94	2.38	3.00	1,790	1,560	2.385
SLB20UU-SUS	LMBS20U-SUS x2	4.00	7.50	2.81	3.500	5.500	0.22	2.0000	1.5000	0.44	2.50	3.00	3.75	2,640	2,540	4.970
SLB24UU-SUS	LMBS24U-SUS x2	4.75	9.00	3.25	4.125	6.500	0.28	2.3750	1.7500	0.50	2.88	3.50	4.50	3,700	3,080	7.775

★1 Dynamic load rating is based on the nominal life of 50km

★2 Main unit : inch

★3 1 lbf = 0.453kgf

SLB_OP OPEN ALUMINUM CASE UNIT-SUS SERIES

● Drawing

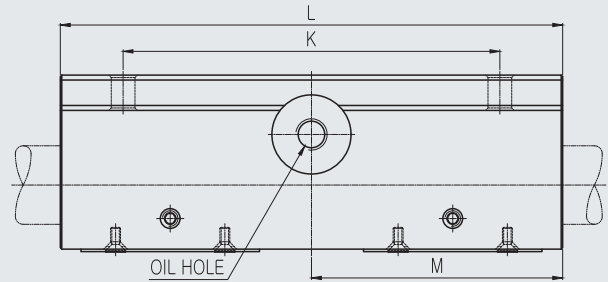
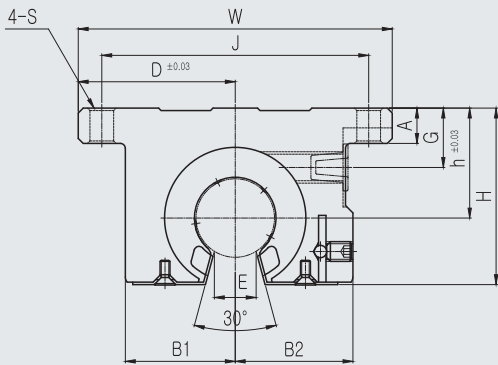

● Part Number Notation

SLB 20 UU OP - SUS



● Aluminum Case Unit
Self-Aligning Linear Bushing(inch type)

● Nominal Shaft Diameter

● Seal

Blank	No Seal
UU	Both Side Seal
U	One Side Seal

● Open type Linear Bushing

● Ball Plate & Ball

SUS	Ball Plate : Stainless steel
	Ball : Stainless steel

SLB_OP OPEN ALUMINUM CASE UNIT-SUS SERIES

PART NUMBER	L/B	W	H	L	J	K	S	D	h	A	B1	B2	M	G	E	BASIC LOAD RATING(lbf)		WEIGHT (gf)
								±0.0012	±0.0012							DYNAMIC (C) ^{*2}	STATIC (Co)	
SLB08UUOP-SUS	LMBS08UOP-SUS x2	2.00	1.100	1.50	1.688	1.000	0.16	1.000	0.687	0.25	0.69	0.75	1.75	0.44	0.27	390	380	0.390
SLB10UUOP-SUS	LMBS10UOP-SUS x2	2.50	1.405	1.75	2.125	1.125	0.19	1.250	0.875	0.28	0.88	0.94	2.00	0.47	0.33	960	680	0.790
SLB12UUOP-SUS	LMBS12UOP-SUS x2	2.75	1.535	1.88	2.375	1.250	0.19	1.375	0.937	0.31	0.94	1.00	2.25	0.51	0.39	1,120	860	0.990
SLB16UUOP-SUS	LMBS16UOP-SUS x2	3.25	1.975	2.62	2.875	1.750	0.22	1.625	1.187	0.38	1.19	1.25	3.00	0.73	0.52	2,020	1,560	1.985
SLB20UUOP-SUS	LMBS20UOP-SUS x2	4.00	2.485	3.38	3.500	2.000	0.22	2.000	1.500	0.44	1.50	1.63	3.75	0.80	0.58	3,020	2,540	4.190
SLB24UUOP-SUS	LMBS24UOP-SUS x2	4.75	2.910	3.73	4.125	2.500	0.28	2.375	1.750	0.50	1.75	1.87	4.50	0.91	0.70	4,200	3,080	6.680

★1 Dynamic load rating is based on the nominal life of 50km

★2 Main unit : inch

★3 1 lbf = 0.453kgf

277

LM Shaft & Support Rail Unit

SAMICK Support Rail Unit

SAMICK Support Rail Unit is assembled of Support Rail, LM Shaft, and Open type Linear Bushing Case. All components are standardized for providing interchangeability, and less cost and designing time.



● Part Number Notation

SBS C g6 30 - 1000 L

● SAMICK Support Rail Unit

SBS	Support Rail Unit for SBR
TBS	Support Rail Unit for TBR

● Shaft (by corrosion resistance)

Blank	Standard(SUJ2)
C	Chrome plated shaft
N	Nickel plated shaft
R	Raydent treated shaft

● Shaft tolerance

g6	Asian standard
h6	European standard

● Shaft Diameter

16~50mm

● Shaft Length

100~3,000mm

SAMICK LM Shaft

SAMICK supply precision LM shaft for SAMICK Linear Bushing. The hardness, surface finishing, and tolerance of shaft must be considered for choosing the proper shaft because the balls are running directly on the shaft surface. Shaft dimensions are as follows

- Material : High carbon chromium bearing steel
- Hardness : HRC58~64
- Hardened depth : 0.8 ~2.5mm
- Surface finishing : 0.8S ~ 1.6S
- Straightness : 0.05mm / 300mm

● Part Number Notation

SF C g6 30 - 1000 L

- SAMICK Support Rail Unit
- Shaft (by corrosion resistance)

Blank	Standard(SUJ2)
C	Chrome plated shaft
N*1	Nickel plated shaft
R	Raydent treated shaft

- Shaft tolerance

g6	Asian standard
h6	European standard

- Shaft Diameter

5~80mm

- Shaft Length

100~3,000mm

★1 under 1m length

LM Shaft special processing

SAMICK also supply specially machined shaft as shown in the below figure. The drilled and tapped holes on LM shaft for mounting on the Support Rail are also available.

<Example>

Drilled or tapped radial hole

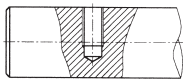

Drill or Tap at the end of LM shaft

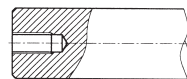

Reduced diameter

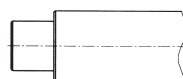

Snap ring groove



Threaded diameters



Flats

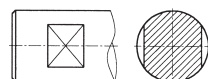

Keyways

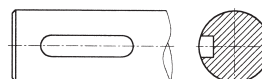

SAMICK LM shaft support

LM shaft support is a support fixture. the exterior is elegant and compact. The upper part is divided to LM shaft length and it can be fixed strongly by fastening bolts.

● Part Number Notation

SK 20

- SAMICK LM shaft support (Material : Aluminum)
- SK Shaft Diameter (8~40mm)

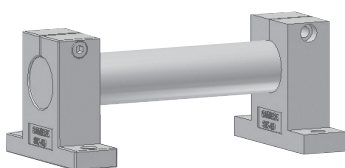

SBS SUPPORT RAIL UNIT

● Drawing

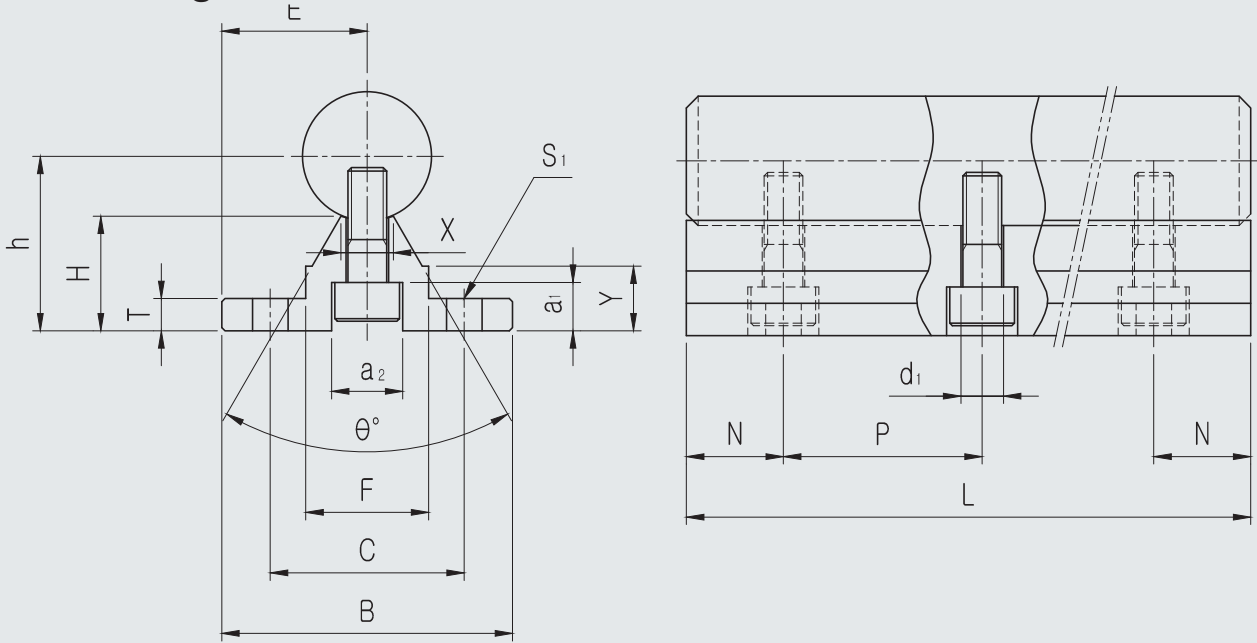

● Part Number Notation

SBS C g6 30 - 1000 L

● SAMICK Support Rail Unit

● Type

SBS	Support Rail Unit for SBR
-----	---------------------------

● Shaft (by corrosion resistance)

Blank	Standard(SUJ2)
C	Chrome plated shaft
N	Nickel plated shaft
R	Raydent treated shaft

● Shaft tolerance

g6	Asian standard
h6	European standard

● Shaft Diameter

16~50mm

● Shaft Length

100~3,000mm



SBS SUPPORT RAIL UNIT

PART NUMBER	LM SHAFT OUTER DIAMETER	E	h	B	H	T	F	X	Y	C	θ	S ₁	a ₁	a ₂	d ₁	WEIGHT (kgf/m)
SBS16	Ø16	20	25	40	17.79	5	18.5	8	11.7	30	80°	Ø5.5	6	9.5	5.5	2.56
SBS20	Ø20	22.5	27	45	17.72	5	19	8	10	30	50°	Ø5.5	6.5	11	6.6	3.50
SBS25	Ø25	27.5	33	55	21.13	6	21.5	8	12	35	50°	Ø6.6	6.5	11	6.6	5.30
SBS30	Ø30	30	37	60	22.85	7	26.5	10.3	13	40	50°	Ø6.6	8.5	14	9	7.38
SBS35	Ø35	32.5	43	65	26.62	8	28	13	15.5	45	50°	Ø9	8.5	14	9	9.68
SBS40	Ø40	37.5	48	75	29.43	9	38	16	17	55	50°	Ø9	8.5	14	9	12.69
SBS50	Ø50	47.5	62	95	38.79	11	45	20	21	70	50°	Ø11	12.5	19	11	20.46

PART NUMBER	MAX. LENGTH (mm)	P	Total Length = 2 × N + NH ^{★2} × P							
			500mm	750mm	1,000mm	1,250mm	1,500mm	2,000mm	2,500mm	3,000mm
SBS16	3,500	150	2(25)+3P	2(75)+4P	2(50)+6P	2(25)+8P	2(75)+9P	2(25)+13P	2(50)+16P	2(75)+19P
SBS20		150	2(25)+3P	2(75)+4P	2(50)+6P	2(25)+8P	2(75)+9P	2(25)+13P	2(50)+16P	2(75)+19P
SBS25		200	2(50)+2P	2(75)+3P	2(100)+4P	2(25)+4P	2(50)+7P	2(100)+9P	2(50)+12P	2(100)+14P
SBS30		200	2(50)+2P	2(75)+3P	2(100)+4P	2(25)+4P	2(50)+7P	2(100)+9P	2(50)+12P	2(100)+14P
SBS35		200	2(50)+2P	2(75)+3P	2(100)+4P	2(25)+4P	2(50)+7P	2(100)+9P	2(50)+12P	2(100)+14P
SBS40		200	2(50)+2P	2(75)+3P	2(100)+4P	2(25)+4P	2(50)+7P	2(100)+9P	2(50)+12P	2(100)+14P
SBS50		200	2(50)+2P	2(75)+3P	2(100)+4P	2(25)+4P	2(50)+7P	2(100)+9P	2(50)+12P	2(100)+14P

- ★1 N values can vary depending on length of Shaft
- ★2 NH (Number of Holes): the number of mounting hole according to pitch value.
- ★3 P & N value must specified when orders.
- ★4 WEIGHT is including LM Shaft's weight.
- ★5 1N ≙ 0.102kgf
- ★6 Main unit : mm

TBS SUPPORT RAIL UNIT

● Drawing

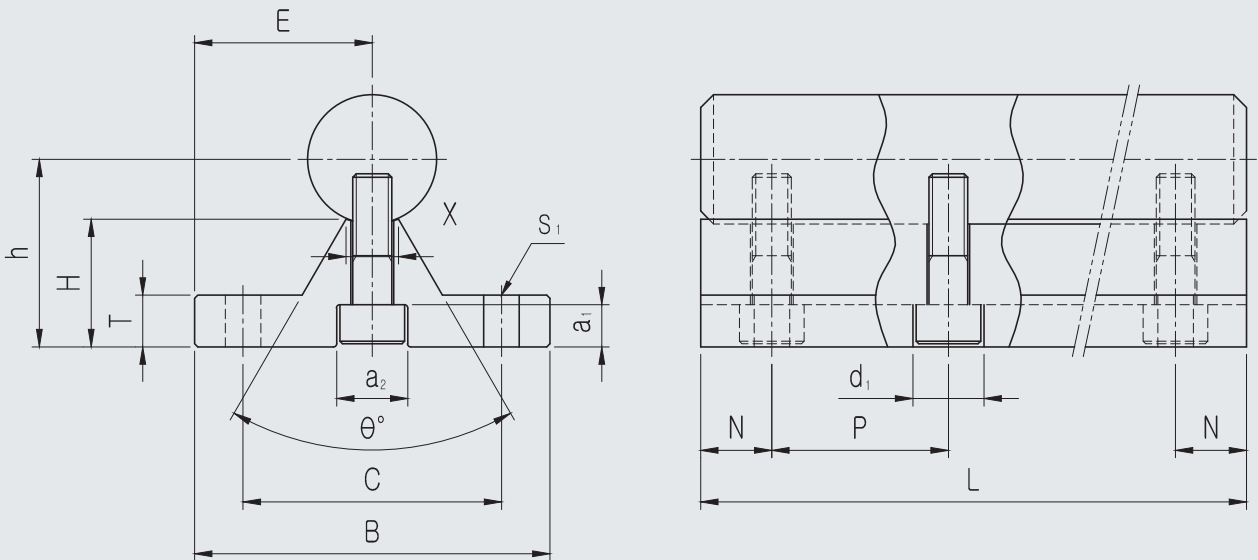

● Part Number Notation

TBS C g6 30 - 1000 L

● SAMICK Support Rail Unit

● Type

TBS	Support Rail Unit for TBR
-----	---------------------------

● Shaft (by corrosion resistance)

Blank	Standard(SUJ2)
C	Chrome plated shaft
N	Nickel plated shaft
R	Raydent treated shaft

● Shaft tolerance

g6	Asian standard
h6	European standard

● Shaft Diameter

16~30mm

● Shaft Length

100~3,000mm



TBS SUPPORT RAIL UNIT

PART NUMBER	LM SHAFT OUTER DIAMETER	E	h	B	H	T	X	C	θ	S ₁	a ₁	a ₂	d ₁	WEIGHT (kgf/m)
TBS16	Ø16	25	22	50	14.79	6	8	37	60°	Ø5.5	6	9.5	5.5	2.66
TBS20	Ø20	27.5	29	55	19.72	8	8	40	50°	Ø5.5	6.5	11	6.6	4.23
TBS25	Ø25	32.5	32	65	20.13	10	8	45	50°	Ø6.6	6.5	11	6.6	5.85
TBS30	Ø30	37.5	36.5	75	22.35	12	10.3	55	50°	Ø6.6	8.5	14	9	8.25

PART NUMBER	MAX. LENGTH (mm)	P	Total Length = 2 × N + NH ^{*2} × P							
			500mm	750mm	1,000mm	1,250mm	1,500mm	2,000mm	2,500mm	3,000mm
TBS16	3,500	150	2(25)+3P	2(75)+4P	2(50)+6P	2(25)+8P	2(75)+9P	2(25)+13P	2(50)+16P	2(75)+19P
TBS20		150	2(25)+3P	2(75)+4P	2(50)+6P	2(25)+8P	2(75)+9P	2(25)+13P	2(50)+16P	2(75)+19P
TBS25		200	2(50)+2P	2(75)+3P	2(100)+4P	2(25)+4P	2(50)+7P	2(100)+9P	2(50)+12P	2(100)+14P
TBS30		200	2(50)+2P	2(75)+3P	2(100)+4P	2(25)+4P	2(50)+7P	2(100)+9P	2(50)+12P	2(100)+14P

- ★1 N values can vary depending on length of Shaft
- ★2 NH (Number of Holes): the number of mounting hole according to pitch value.
- ★3 P & N value must specified when orders.
- ★4 WEIGHT is including LM Shaft's weight.
- ★5 1N ≙ 0.102kgff
- ★6 Main unit : mm

SK Shaft Support

● Drawing

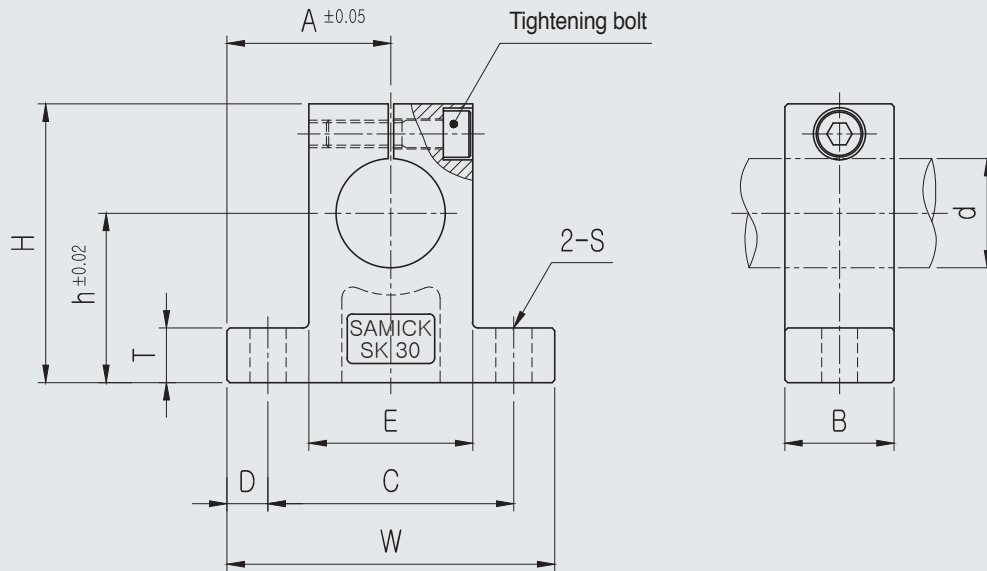

● Part Number Notation

SK **20**

- SAMICK LM shaft support (Material : Aluminum)
- Shaft Diameter : 8~40mm

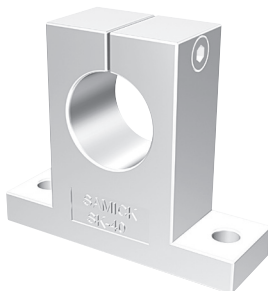

SK Shaft Support

Unit : mm

PART NUMBER	LM SHAFT DIAMETER	h	A	W	H	T	E	D	C	B	S	J	WEIGHT (gf)
SK08	Ø8	20	21	42	32.8	6	18	5	32	14	Ø5.5	M4	24
SK10	Ø10	20	21	42	32.8	6	18	5	32	14	Ø5.5	M4	24
SK12	Ø12	23	21	42	38	6	20	5	32	14	Ø5.5	M4	30
SK13	Ø13	23	21	42	38	6	20	5	32	14	Ø5.5	M4	30
SK16	Ø16	27	24	48	44	8	25	5	38	16	Ø5.5	M4	40
SK20	Ø20	31	30	60	51	10	30	7.5	45	20	Ø6.6	M5	70
SK25	Ø25	35	35	70	60	12	38	7	56	24	Ø6.6	M6	130
SK30	Ø30	42	42	84	70	12	44	10	64	28	Ø9	M6	180
SK35	Ø35	50	49	98	85	15	50	12	74	32	Ø11	M8	270
SK40	Ø40	60	57	114	96	15	60	12	90	36	Ø11	M8	420

SF LM Shaft

● Drawing

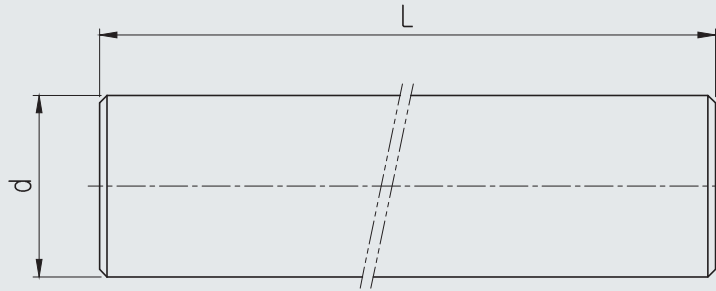

● Part Number Notation

SF C g6 30 - 1000 L

● SAMICK LM Shaft

● Shaft (by corrosion resistance)

Blank	Standard(SUJ2)
C	Chrome plated shaft
N*1	Nickel plated shaft
R	Raydent treatment

● Shaft tolerance

g6	Asian standard
h6	European standard

● Shaft Diameter

5~80mm

● Shaft Length

100~3,000mm

★1 Under 1m length



SF LM Shaft

diameter	Ø5	Ø6	Ø8	Ø10	Ø12	Ø13	Ø16	Ø20	Ø25	Ø30	Ø35	Ø40	Ø50	Ø60	Ø80
Shaft toleranc (g6)	-0.004 -0.012	-0.004 -0.012	-0.005 -0.014		-0.006 -0.017			-0.007 -0.020		-0.009 -0.025			-0.010 -0.029		
WEIGHT (kg/m)	0.16	0.22	0.39	0.62	0.89	1.04	1.58	2.46	3.85	5.55	7.55	9.86	15.41	22.18	39.44
MAX. LENGTH(mm)	500	500	500	2,000	2,000	2,000	3,000	3,000	3,000	3,000	3,000	3,000	3,000	3,000	3,000

■ LM Shaft specification

- Material : SUJ2(High carbon chromium bearing steel)
- Hardness : H_RC 58~64
- Hardened depth : 0.8~2.5mm
- Surface finishing : 0.8S~1.6S
- Straightness : 0.05mm/300mm

289

References

Hardness Conversion Table

Rockwell C Scale H _R C	Vickers ¹ Hardness H _v	Briell Hardness H _B		Rockwell Hardness		Shore Hardness H _s
		Standard Ball	Tungsten Carbon Ball	H _R A A Scale	H _R B B Scale	
68	940	-	-	85.6	-	97
67	900	-	-	85.0	-	95
66	865	-	-	84.5	-	92
65	832	-	739	83.9	-	91
64	800	-	722	83.4	-	88
63	772	-	705	82.8	-	87
62	746	-	688	82.3	-	85
61	720	-	670	81.8	-	83
60	697	-	654	81.2	-	81
59	674	-	634	80.7	-	80
58	653	-	615	80.1	-	78
57	633	-	595	79.6	-	76
56	613	-	577	79.0	-	75
55	595	-	560	78.5	-	74
54	577	-	543	78.0	-	72
53	560	-	525	77.4	-	71
52	544	500	512	76.8	-	69
51	528	487	496	76.3	-	68
50	513	475	481	75.9	-	67
49	498	464	469	75.2	-	66
48	484	451	455	74.7	-	64
47	471	442	443	74.1	-	63
46	458	432	432	73.6	-	62
45	446	421	421	73.1	-	60
44	434	409	409	72.5	-	58
43	423	400	400	72.0	-	57
42	412	390	390	71.5	-	56
41	402	381	381	70.9	-	55
40	392	371	371	70.4	-	54
39	382	362	362	69.9	-	52
38	372	353	353	69.4	-	51
37	363	344	344	68.9	-	50
36	354	336	336	68.4	(109.0)	49
35	345	327	327	67.9	(108.5)	48
34	336	319	319	67.4	(108.0)	47
33	327	311	311	66.8	(107.5)	46
32	318	301	301	66.3	(107.0)	44
31	310	294	294	65.8	(106.0)	43
30	302	286	286	65.3	(105.5)	42
29	294	279	279	64.7	(104.5)	41
28	286	271	271	64.3	(104.0)	41
27	279	264	264	63.8	(103.0)	40
26	272	258	258	63.3	(102.5)	38
25	266	253	253	62.8	(101.5)	38
24	260	247	247	62.4	(101.0)	37
23	254	243	243	62.0	100.0	36
22	248	237	237	61.5	99.0	35
21	243	231	231	61.0	98.5	35
20	238	226	226	60.5	97.8	34
(18)	230	219	219	-	96.7	33
(16)	222	212	212	-	95.5	32
(14)	213	203	203	-	93.9	31
(12)	204	194	194	-	92.3	29
(10)	196	187	187	-	90.7	28
(8)	188	179	179	-	89.5	27
(6)	180	171	171	-	87.1	26
(4)	173	165	165	-	85.5	25
(2)	166	158	158	-	83.5	24
0	160	152	152	-	81.7	24

Fitting Tolerances for Shaft and Housing Bore Diameter (Metric Series)

Nominal Diameter(mm)		Tolerance of Shaft Diameter(μm)																		
		f			g			h				js			j			k		
over	incl	f5	f6	f7	g5	g6	g7	h5	h6	h7	h8	js5	js6	js7	j5	j6	j7	k5	k6	k7
-	3	-6 -10 -12 -16			-2 -6 -8 -12			0 -4 -6 -10 -14				± 2	± 3	± 5	+2 +4 -2	+6 -4	+4 +6 +10 0			
3	6	-10 -15 -18 -22			-4 -9 -12 -16			0 -5 -8 -12 -18				± 2.5	± 4	± 5	+3 +6 -2	+8 -4	+6 +9 +13 +1			
6	10	-6 -19 -22 -28			-5 -11 -14 -20			0 -6 -9 -15 -22				± 3	± 4.5	± 7	+4+7 -2	+10 -5	+7+10+16 +1			
10	14	-16 -24 -27 -34			-6 -14 -17 -24			0 -8 -11 -18 -27				± 4	± 5.5	± 9	+5 +8	+12	+9 +12 +19 +1			
14	18														+3 -3	-6				
18	24	-20 -29 -33 -41			-7 -16 -20 -28			0 -9 -13 -21 -33				± 4.5	± 6.5	± 10	+5 +9	+13	+11 +15 +23 +2			
24	30														+4 -4	-8				
30	40	-25 -36 -41 -50			-9 -20 -25 -34			0 -11 -16 -25 -39				± 5.5	± 8	± 12	+6 +11	+15	+13 +18 +27 +2			
40	50														+6 -5	-10				
50	65	-30 -43 -49 -60			-10 -23 -29 -40			0 -13 -19 -30 -46				± 6.5	± 9.5	± 15	+6 +12	+18	+15 +21 +32 +2			
65	80														+6 -7	-12				
80	100	-36 -51 -85 -71			-12 -27 -34 -47			0 -15 -22 -35 -54				± 7.5	± 11	± 17	+6 +13	+20	+18 +25 +38 +3			
100	120														+6 -9	-15				
120	140	-43 -61 -68 -83			-14 -32 -39 -54			0 -18 -25 -40 -63				± 9	± 12.5	± 20	+7 +14	+22	+21 +28 +43 +3			
140	160														+7 -11	-18				
160	180																			

Nominal Diameter(mm)		Tolerance of Housing Bore(μm)																
		H				JS				J			K			M		
over	incl	H5	H6	H7	H8	JS5	JS6	JS7	JS8	J6	J7	J8	K6	K7	K8	M6	M7	M8
-	3	+4 +6 +20 +25 0				± 2	± 3	± 5	± 7	+2 -4	+4 -6	+6 -8	0 -6	0 -10	0 -14	-2 -8	-2 -12	-2 -16
3	6	+5 +8 +12 -18 0				± 2.5	± 4	± 6	± 9	+5 -3	+6 -6	+10 -8	+2 -6	+3 -9	+5 -14	-1 -9	0 -12	+2 -16
6	10	+6 +9 +15 +22 0				± 3	± 4.5	± 7	± 11	+5 -4	+8 -7	+12 -10	+2 -7	+5 -10	+6 -16	-3 -12	0 -15	+1 -21
10	14	+8 +11 +18 +27 0				± 4	± 5.5	± 9	± 13	+6	+10	+15	+2	+6	+8	-4	0	+2
14	18									-5	-8	-12	-9	-12	-19	-15	-18	-25
18	24	+9 +13 +21 +33 0				± 4.5	± 6.5	± 10	± 16	+8	+12	+20	+2	+6	+10	-4	0	+4
24	30									-5	-9	-13	-11	-15	-23	-17	-21	-29
30	40	+11 +16 +25 +39 0				± 5.5	± 8	± 12	± 19	+10	+14	+24	+3	+7	+12	-4	0	+5
40	50									-6	-11	-15	+13	-18	-27	-20	-25	-34
50	65	+13 +19 +30 +46 0				± 6.5	± 9.5	± 15	± 23	+13	+18	+28	+4	+9	+14	-5	0	+5
65	80									-6	-12	-18	-15	-21	-32	-24	-30	-41
80	100	+15 +22 +35 +54 0				± 7.5	± 11	± 17	± 27	+16	+22	+34	+4	+10	+16	-6	0	+6
100	120									-6	-13	-20	-18	-25	-38	-28	-35	-48
120	140	+18 +25 +40 +63 0				± 9	± 12.5	± 20	± 31	+18	+26	+41	+4	+12	+20	-8	0	+8
140	160									-7	-14	-22	-21	-28	-43	-33	-40	-55
160	180																	

Fitting Tolerances for Shaft and Housing Bore Diameter^(inch Series)

●● Tolerance of housing bore

	SIZE		H5		H6		H7		H8	
	inch	mm	inch	mm	inch	mm	inch	mm	inch	mm
OVER BELOW	0.1181 0.2362	3 6	0.0002 0	0.005 0	0.0003 0	0.008 0	0.0004 0	0.012 0	0.0007 0	0.018 0
OVER BELOW	0.2362 0.3937	6 10	0.0002 0	0.006 0	0.0003 0	0.009 0	0.0003 0	0.015 0	0.0008 0	0.022 0
OVER BELOW	0.3937 0.7087	10 18	0.0003 0	0.008 0	0.0004 0	0.011 0	0.0007 0	0.018 0	0.0010 0	0.027 0
OVER BELOW	0.7087 1.1811	18 30	0.0003 0	0.009 0	0.0005 0	0.013 0	0.0008 0	0.021 0	0.0013 0	0.033 0
OVER BELOW	1.1811 1.9685	30 50	0.0004 0	0.011 0	0.0006 0	0.016 0	0.0009 0	0.025 0	0.0015 0	0.039 0
OVER BELOW	1.9685 3.1496	50 80	0.0005 0	0.013 0	0.0007 0	0.019 0	0.0011 0	0.030 0	0.0018 0	0.046 0
OVER BELOW	3.1496 4.7244	80 120	0.0005 0	0.015 0	0.0008 0	0.022 0	0.0013 0	0.035 0	0.0021 0	0.054 0

●● Tolerance of Shaft Diameter

	SIZE		g5		g6		g7		h5		h6		h7	
	inch	mm	inch	mm	inch	mm	inch	mm	inch	mm	inch	mm	inch	mm
OVER BELOW	0.1181 0.2362	3 6	-0.0001 -0.0003	-0.004 -0.009	-0.0001 -0.0004	-0.004 -0.012	-0.0001 -0.0006	-0.004 -0.016	0 -0.0002	0 -0.005	0 -0.0003	0 -0.008	0 -0.0004	0 -0.012
OVER BELOW	0.2362 0.3937	6 10	-0.0002 -0.0004	-0.005 -0.011	-0.0002 -0.0005	-0.005 -0.014	-0.0002 -0.0007	-0.005 -0.020	0 -0.0002	0 -0.006	0 -0.0003	0 -0.009	0 -0.0006	0 -0.015
OVER BELOW	0.3937 0.7087	10 18	-0.0002 -0.0005	-0.006 -0.014	-0.0002 -0.0006	-0.006 -0.017	-0.0002 -0.0009	-0.006 -0.024	0 -0.0003	0 -0.008	0 -0.0004	0 -0.011	0 -0.0007	0 -0.018
OVER BELOW	0.7087 1.1811	18 30	-0.0002 -0.0006	-0.007 -0.016	-0.0002 -0.0007	-0.007 -0.020	-0.0002 -0.0011	-0.007 -0.028	0 -0.0003	0 -0.009	0 -0.0005	0 -0.013	0 -0.0008	0 -0.021
OVER BELOW	1.1811 1.9685	30 50	-0.0003 -0.0007	-0.009 -0.020	-0.0003 -0.0009	-0.009 -0.025	-0.0003 -0.0013	-0.009 -0.034	0 -0.0004	0 -0.011	0 -0.0006	0 -0.016	0 -0.0009	0 -0.025
OVER BELOW	1.9685 3.1496	50 80	-0.0004 -0.0009	-0.010 -0.023	-0.0004 -0.0011	-0.010 -0.029	-0.0004 -0.0015	-0.010 -0.04	0 -0.0005	0 -0.013	0 -0.0007	0 -0.019	0 -0.011	0 -0.030
OVER BELOW	3.1496 4.7244	80 120	-0.0004 -0.0010	-0.012 -0.027	-0.0004 -0.0013	-0.012 -0.034	-0.0004 -0.0018	-0.012 -0.047	0 -0.0006	0 -0.015	0 -0.0008	0 -0.022	0 -0.0013	0 -0.035

Equations for shaft deflection amount calculation

Variations of support and Load

Equation for Deflection Amount

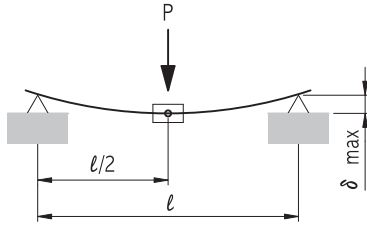

$$\delta_{\max} = \frac{P \cdot l^3}{48 \cdot E \cdot I} = 2.021 \times 10^{-5} \frac{P \cdot l^3}{d^4}$$

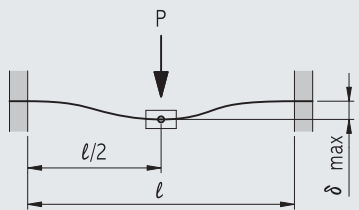

$$\delta_{\max} = \frac{P \cdot l^3}{192 \cdot E \cdot I} = 5.053 \times 10^{-6} \frac{P \cdot l^3}{d^4}$$

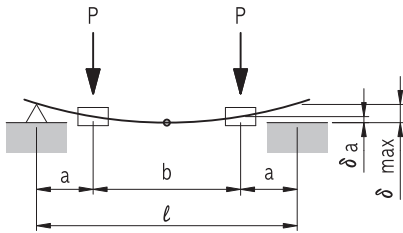

$$\delta_a = \frac{P \cdot a^2}{6 \cdot E \cdot I} (2a + 3b) = 1.617 \times 10^{-4} \frac{P \cdot a^2 (2a + 3b)}{d^4}$$

$$\delta_{\max} = \frac{P \cdot a^2}{24 \cdot E \cdot I} (3l^2 - 4a^2) = 4.042 \times 10^{-5} \frac{P \cdot a \cdot (3l^2 + 4a^2)}{d^4}$$

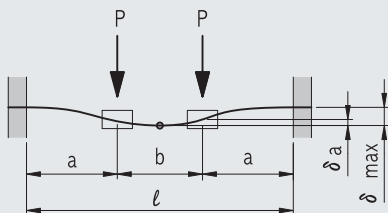

$$\delta_a = \frac{P \cdot a^3}{6 \cdot E \cdot I} \left(2 - \frac{3a}{l}\right) = 1.617 \times 10^{-4} \frac{P \cdot a^3}{d^4} \left(2 - \frac{3a}{l}\right)$$

$$\delta_{\max} = \frac{P \cdot a^2}{24 \cdot E \cdot I} (2a + 3b) = 4.042 \times 10^{-5} \frac{P \cdot a^2 \cdot (2a + 3b)}{d^4}$$

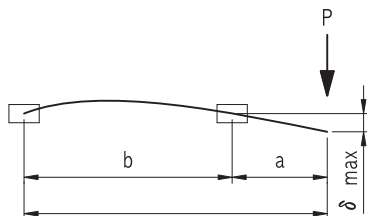

$$\delta_{\max} = \frac{P \cdot a^2 \cdot l}{3 \cdot E \cdot I} = 3.234 \times 10^{-4} \frac{P \cdot a^2 \cdot l}{d^4}$$

E : Modulus of Longitudinal elasticity 2.1×10^4 (kgf/mm²)

P : Applying Load (kgf)

I : Geometrical Moment of Inertia (mm⁴) ; $I = \pi d^4 / 64$, Hollow shaft : $I = \pi (d^4 - d_i^4) / 64$

d_i : Shaft inner-diameter (mm), d : Shaft Outer-diameter (mm)



SAMICK



SAMICK PRECISION IND. CO.,LTD.

(P.C 42721) 39 Seongseogongdannam-ro 32-gil,
Dalseo-gu, Daegu, Korea (South)
TEL : +82-53-**666-7100** FAX : +82-53-**583-4669**
Web site www.mysamick.com
E-mail marketing@mysamick.com