



ANNO 1978

for reliable rotation in maintenance and production

BETEX®

HYDRAULIC PULLERS

BETEX HP 2/3-arm pullers, with integrated pump and cylinder



Compact, ergonomic design, easily operated by one person!

- **Multifunctional:**
These HP-pullers are ideal for pulling a wide variety of parts, including bearings, bushings, wheels, gears and pulleys. Applications for HP-pullers will be found in motor repair shops, service companies, maintenance shops, industry, mining, paper mills, chemical plants, shipping, offshore, etc.
- **Compact:**
The self contained hydraulic pump and cylinder save space, as you don't need a separate pump, hose or puller.
- **Strong:**
The harder the force, the tighter the jaws grip. The arms cannot bend or deflect.
- **Economical**
2/3-arm combination puller, 2 pullers for the price of one, including integrated pump and cylinder!
- **Safe:**
The improved integral safety release valve prevents overloading and ensures that you will never exceed the maximum power capacity.
- **Versatile:**
Various accessories are available. Sets are supplied in practical PE case and consist of a puller block, connecting rods and a set of bearing splitters.

4, 6, 8, 12, 20 and 30 ton capacity!

BETEX HP 2/3 HYDRAULIC PULLERS

Type	Art.no.	Cap. ton	Max. shaft length mm	Max. spread mm	Stroke mm	A	B	C	D	E	F	G	Weight kg
HP 43 *	791000	4	185	275	60	11	6	22	32	84	42	22	4.5
HP 63 *	792000	6	215	300	85	11	10	25	51	122	45	25	6.5
HP 83 *	793000	8	230	350	85	11	10	25	51	122	50	25	6.5
HP 123 *	794000	12	270	375	85	14	10	29	51	118	60	28	8.0
HP 203**	796000	20	360	520	111	20	27	33	60	161	80	40	22.0
HP 303 **	797000	30	360	550	111	20	27	38	60	155	68	50	32.0

* Incl. safety net ** incl. safety blanket

ACCESSORY SETS FOR 4, 6, 8, 12 TON PULLERS

Puller block, connecting rods (legs), incl. set of bearing splitters for a min./max Ø 25-225 mm

Type	Art.no.	Shaft length mm	Min/max Spread mm	Weight kg
Acc. Set HP 43	791100	250	Ø 25-110	8.5
Acc. Set HP 63	792100	280	Ø 50-150	12.5
Acc. Set HP 83	793100	280	Ø 50-150	12.5
Acc. Set HP 123	794100	325	Ø 80-225	18.0

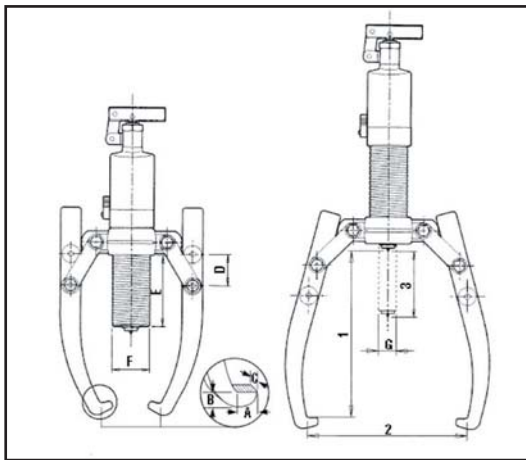

2-stage pump: Models HP 20 and 30 tons are designed with an innovative 2-stage pump. Pumping is now lighter, quicker and safer!

Convenient: the 360° rotatable pump handle provides flexibility for using the puller in the most convenient position. The telescopic pump handle ensures optimal force transmission.

