

NSK S1™ Series Precision Linear Guides

Series of interchangeable products enables fast delivery.

A new guide way system for machinery ensures environmental compatibility and high performance. Its quiet, smooth operation is friendly to both the workplace and the environment.

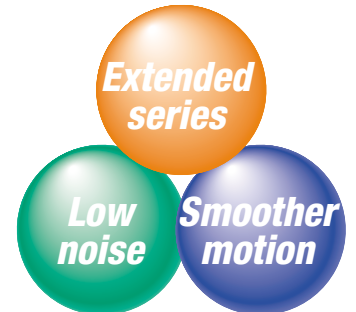

Patent Pending



The NSK S1™ Series meets the demand for smoother, silent motion

The popular series has been updated and expanded into a complete lineup with a new series of interchangeable products!

The NSK S1™ Series Linear Guide features resin retainers between the balls to prevent collision and rubbing.

Ball groove construction is standard in the LH and LS Series.

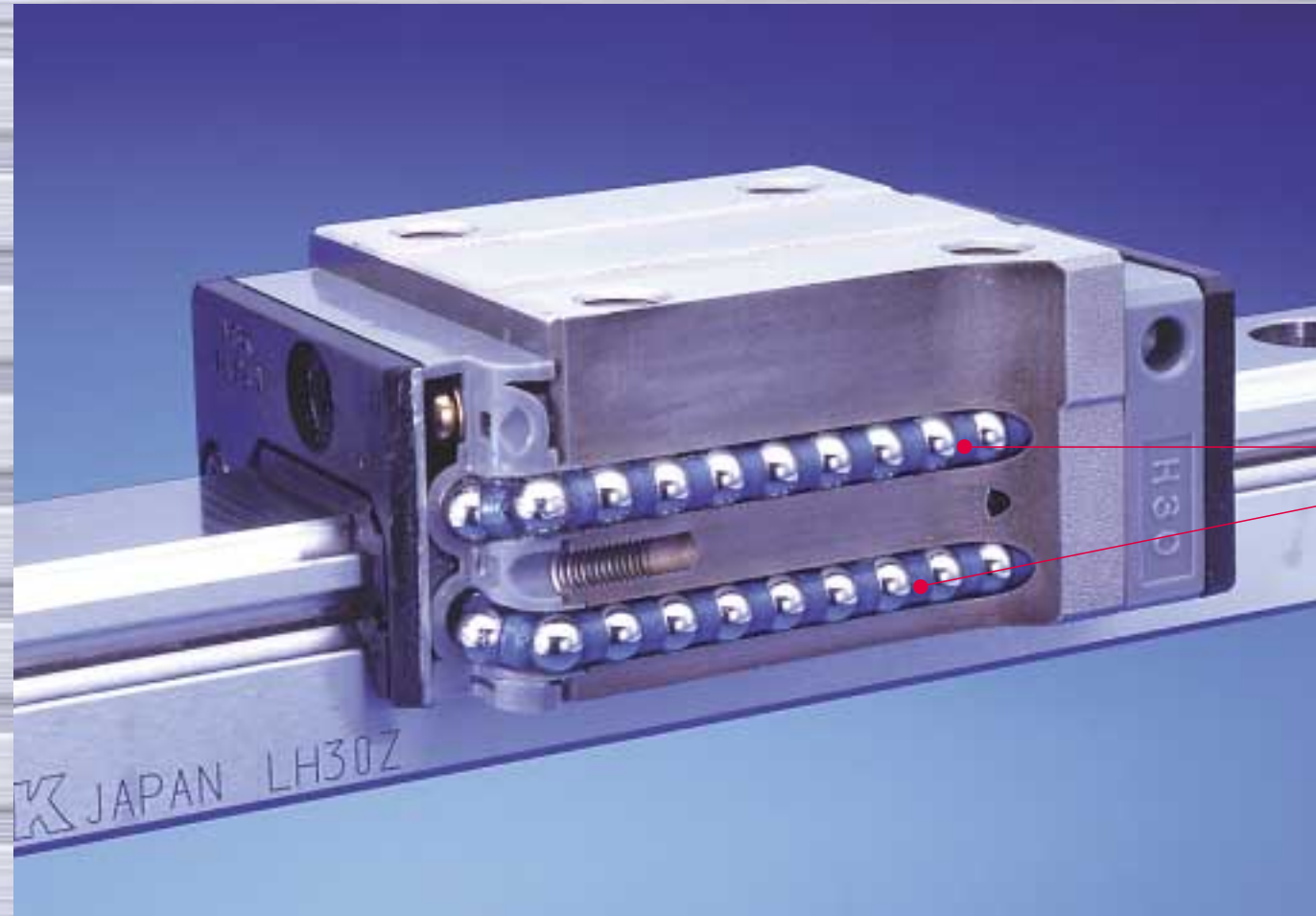

Resin retaining piece

Feature 1 Lower noise and gentler tone

Incorporating a retainer piece and optimizing the circulation path enables steel ball circulation stability and the prevention of ball collision, resulting in noise reduction by 5 dB (A) or more than that of conventional NSK products. In addition, contributing to sound improvement (human-friendly sound quality) with lower noise levels, especially in the high-frequency range.

Lower noise and gentler tone

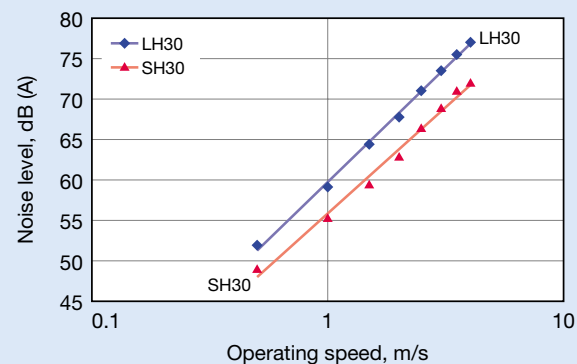

Fig. 1 Noise level comparison between LH30 and SH30



Fig. 2 Noise level comparison between LS20 and SS20

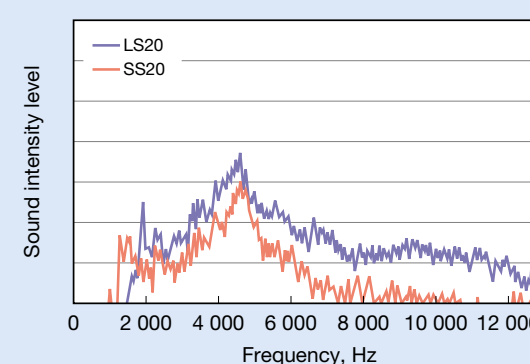

Fig. 3 Noise level comparison between LS20 and SS20

Test conditions: Oil lubrication (VG68)
Locate a microphone at 500 mm above the sample (both for LH30 and LS20)

*Noise level depends on the microphone location.

Noise level drops by approximately 6 dB (A) when the distance from the microphone is doubled.

NSK S1™ Series Precision Linear Guides

Feature 2 Smoother motion

Improved steel ball circulation stability, free of interference between the balls improves dynamic friction characteristics, resulting in smooth and stable motion, which is especially effective for low speed motion.

Smoother motion

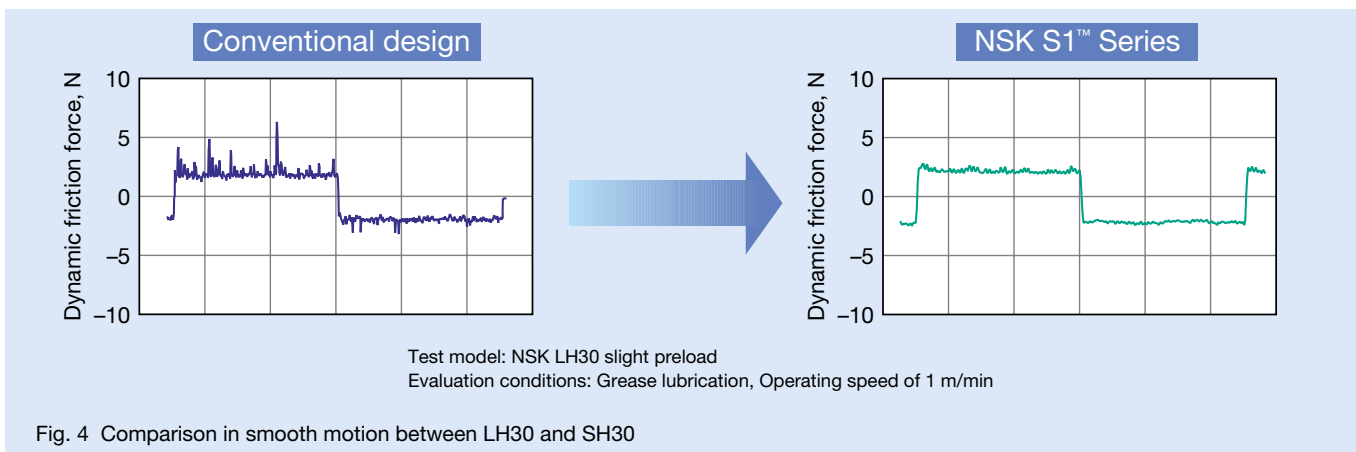

Feature 3 Low dust generation

A resin retaining piece, which prevents steel balls collision, features effective low dust generation characteristics compared to conventional products.

Remarkable low dust generation

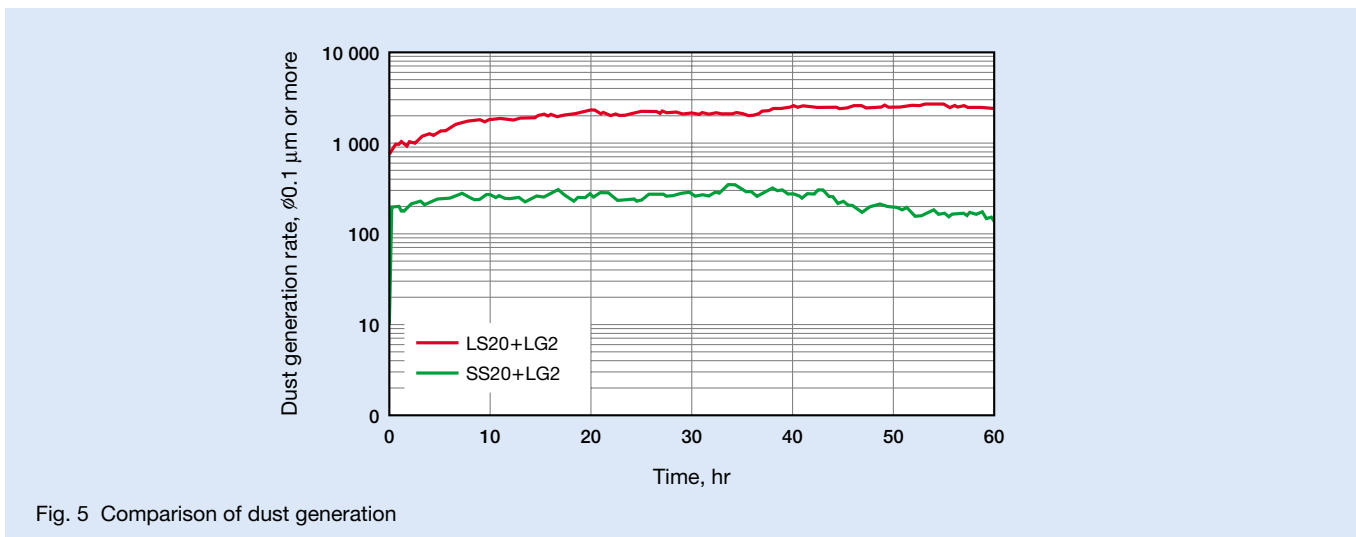

Feature 4 Fast delivery

Lineup of interchangeable rails and ball slides in the series supports random matching and facilitates fast delivery.

1. Accuracy

The preloaded assembly types products have four accuracy grades; Ultra precision P3, Super precision P4, High precision P5 and Precision P6, while the interchangeable types have a regular class PC.

Table 1 shows the accuracy standard for the preloaded assembly type of the SH Series and SS Series, while Table 2 shows the accuracy standard for the interchangeable types.

Table 1 Accuracy grade for the preloaded assembly type

Unit: μm

Item	Accuracy grade	Ultra precision P3	Super precision P4	High precision P5	Precision P6
Mounting height: H Variation of mounting height: H (All slides on a pair or rails)		± 10 3	± 10 5	± 20 7	± 40 15
Mounting width dimension: W_2 or: W_3 Variation of mounting width dimension: $W_2(s)$ or: $W_3(s)$ (All slides on datum rails)		± 15 3	± 15 7	± 25 10	± 50 20
Running parallelism of face C against face A Running parallelism of face D against face B		Shown in Table 3			

Table 2 Accuracy grade for the interchangeable type

Item	Accuracy grade	Normal interchangeable types PC
Mounting height: H Variation of mounting height: H (one rail) Variation of mounting height: H (multiple rails)		± 20 15 30
Assembly width dimension: W_2 or : W_3 Variation of assembly width dimension: $W_2(s)$ or: $W_3(s)$ (All slides on datum rails)		± 30 25
Running parallelism of face C against face A Running parallelism of face D against face B		Shown in Table 3

Table 3 Running parallelism tolerance

Rail length (mm)		Preload assembly types				Interchangeable types
		Ultra precision P3	Super precision P4	High precision P5	Precision P6	Normal interchangeable type PC
over	or less	P3	P4	P5	P6	PC
50		2	2	2	4.5	6
50–80		2	2	3	5	6
80–125		2	2	3.5	5.5	6.5
125–200		2	2	4	6	7
200–250		2	2.5	5	7	8
250–315		2	2.5	5	8	9
315–400		2	3	6	9	11
400–500		2	3	6	10	12
500–630		2	3.5	7	12	14
630–800		2	4.5	8	14	16
800–1 000		2.5	5	9	16	18
1 000–1 250		3	6	10	17	20
1 250–1 600		4	7	11	19	23
1 600–2 000		4.5	8	13	21	26
2 000–2 500		5	10	15	22	29
2 500–3 150		6	11	17	25	32
3 150–4 000		9	16	23	30	34

NSK S1™ Series Precision Linear Guides

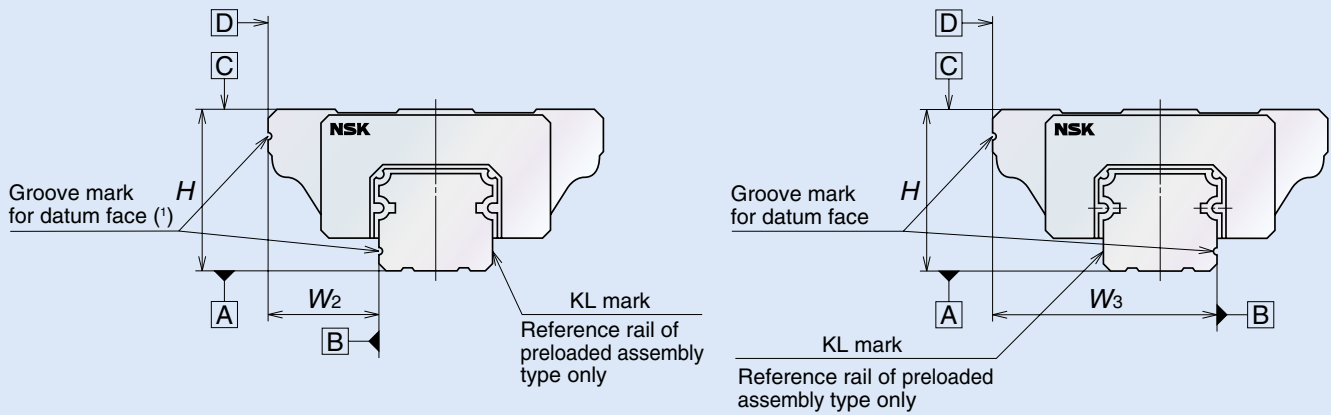

Fig. 6 Assembly dimensions

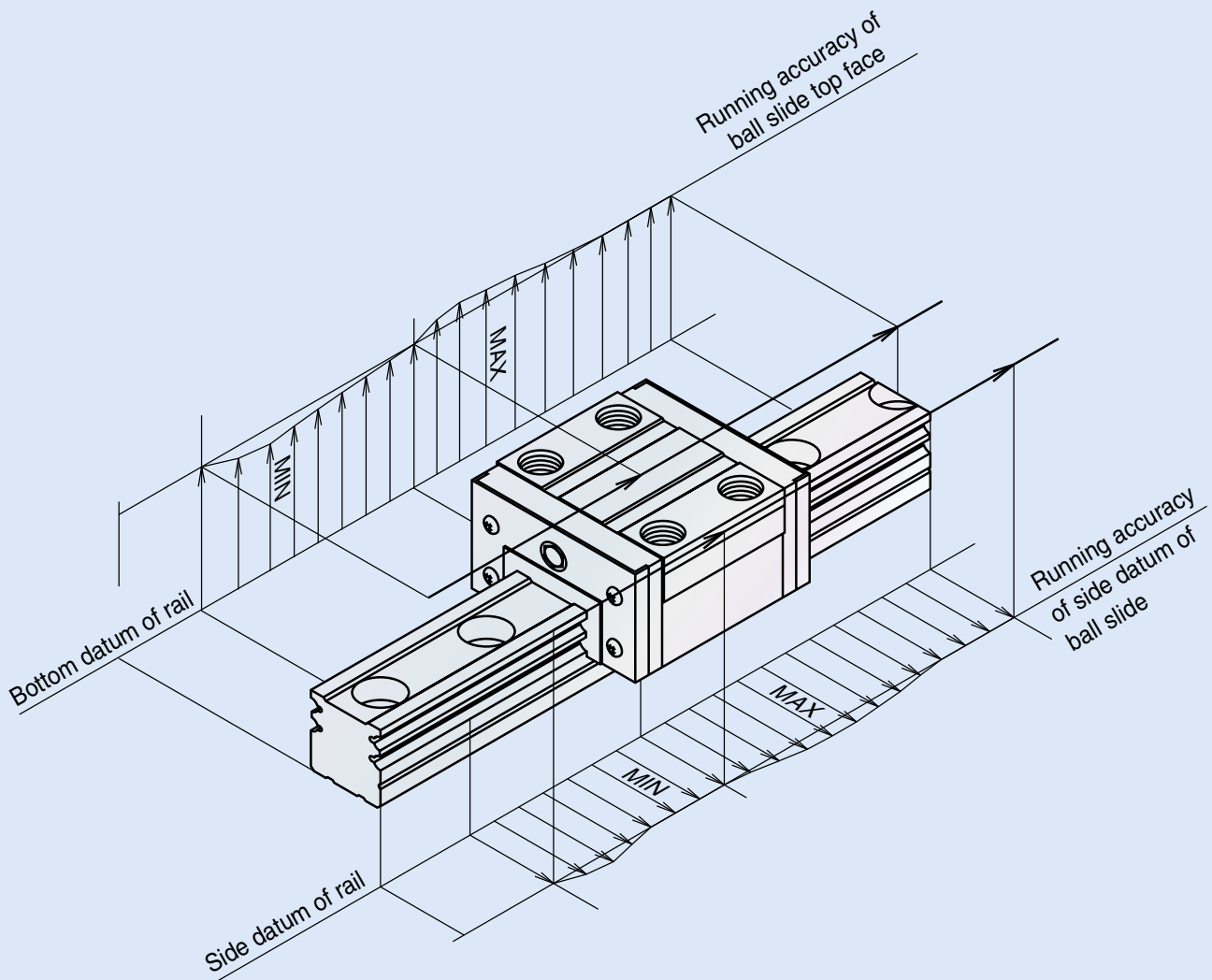

Fig. 7 Running parallelism

2. Preload and rigidity

We offer three levels of preload: Medium preload (Z3), Slight preload (Z1) and Fine clearance (Z0), along with interchangeable types of Fine clearance

(ZZ). Values for preload and rigidity of the SH and SS Series are shown in Tables 4 and 5.

Table 4 Preload and rigidity of the SH Series

Model		Preload (N)		Rigidity (N/μm)			
				Vertical direction		Lateral direction	
		Slight preload (Z1)	Medium preload (Z3)	Slight preload (Z1)	Medium preload (Z3)	Slight preload (Z1)	Medium preload (Z3)
High load capacity type	SH15 AN, EL, FL	78	441	127	215	88	166
	SH20 AN, EL, FL	147	784	157	274	127	225
	SH25 AN, AL, EL, FL	196	1 180	186	343	137	255
	SH30 AN, AL	245	1 470	196	363	137	265
	SH30 EL, FL	294	1 670	245	441	176	323
	SH35 AN, AL, EL, FL	390	2 160	294	529	205	382
Ultra high load capacity type	SH15 BN, GL, HL	98	637	186	333	137	264
	SH20 BN, GL, HL	196	1 080	235	421	186	343
	SH25 BN, BL, GL, HL	245	1 570	284	529	196	382
	SH30 BN, BL, GL, HL	343	2 160	333	627	235	451
	SH35 BN, BL, GL, HL	490	2 840	411	755	284	529

Note: Because the clearance value for Fine clearance (Z0) is 0–3μm, the preload value is zero.

Table 5 Preload and rigidity of the SS Series

Model		Preload (N)		Rigidity (N/μm)			
				Vertical direction		Lateral direction	
		Slight preload (Z1)	Medium preload (Z3)	Slight preload (Z1)	Medium preload (Z3)	Slight preload (Z1)	Medium preload (Z3)
High load capacity type	SS15 AL, EL, FL	69	392	118	216	88	157
	SS20 AL, EL, FL	88	490	147	255	108	186
	SS25 AL, EL, FL	147	833	196	353	137	255
	SS30 AL, EL, FL	245	1 370	245	441	176	323
	SS35 AL, EL, FL	294	1 860	284	539	205	392
Medium load capacity type	SS15 CL, JL, KL	39	245	69	127	49	88
	SS20 CL, JL, KL	59	343	88	157	59	118
	SS25 CL, JL, KL	98	588	108	206	78	147
	SS30 CL, JL, KL	147	882	127	235	98	176
	SS35 CL, JL, KL	196	1 180	166	304	117	225

Note: Because the clearance value for Fine clearance (Z0) is 0–3μm, the preload value is zero.

Preload value of SH and SH Series interchangeable types are shown in Table 6.

Table 6 Preload and rigidity of the interchangeable types

Model	Slight preload ZZ	Model	Slight preload ZZ
SH15	-4-0	SS15	-4-0
SH20	-5-0	SS20	-4-0
SH25	-5-0	SS25	-5-0
SH30	-7-0	SS30	-5-0
SH35	-7-0	SS35	-8-0

unit: μm

Negative values indicate preload volume (elastic deformation of balls).

NSK S1™ Series Precision Linear Guides

3. Reference number

This number comprises codes and numbers which indicate key specifications, and is generated when the customer and NSK have defined specifications.

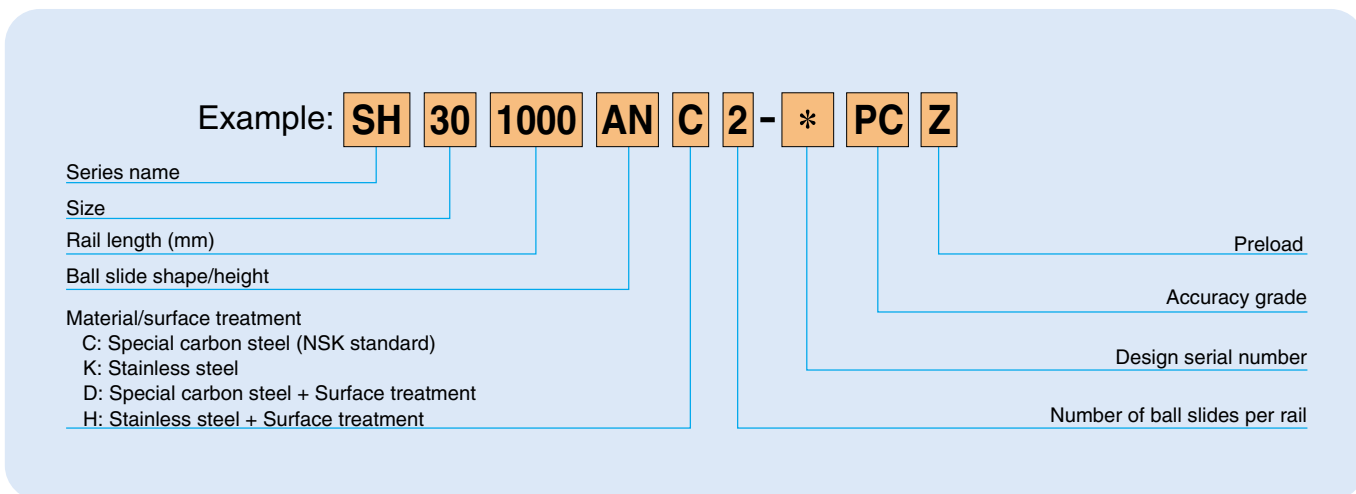

3.1 Combination of accuracy and preload

		Accuracy grade				
		Ultra super precision	Super precision	Precision	High	Normal interchangeable type
Without NSK K1 lubrication unit		P3	P4	P5	P6	PC
With NSK K1 lubrication unit		K3	K4	K5	K6	KC
Preload	Fine clearance Z0	○	○	○	○	—
	Slight preload Z1	○	○	○	○	—
	Medium preload Z3	○	○	○	○	—
	Interchangeable preload ZZ	—	—	—	—	○

○: Available

3.2 Reference number for single bearing of interchangeable types

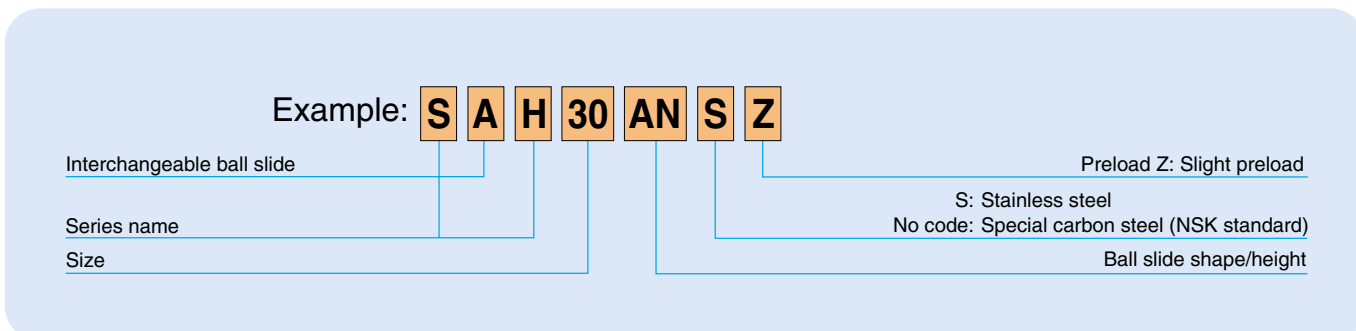

3.3 Reference number for single rail of interchangeable types

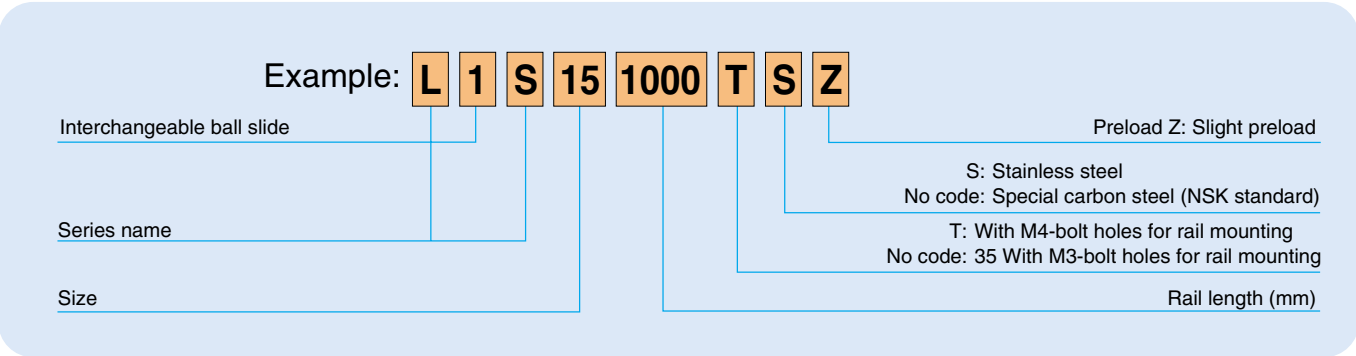
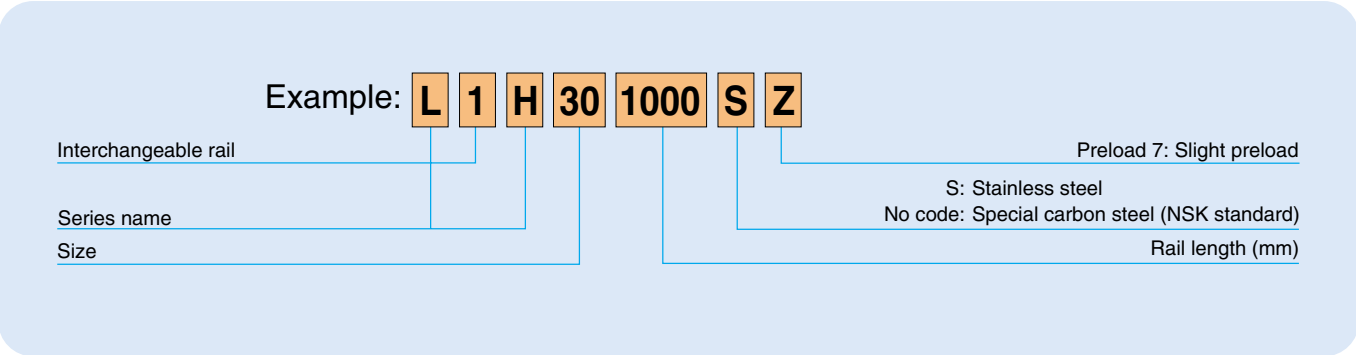

4. Application examples

- Applications that require lower noise levels and a lower level of vibration
Instruments, printers, medical equipment, office machines, etc.
- Applications that require smoother motion
Electric wire cutting discharge machines, scanners and pattern generators and steppers.

Handling Precautions

1. Temperature range Maximum operating temperature: 50°C
Maximum momentary temperature: 80°C
2. Usage conditions We recommend using “NSK S1™ Series” products in a clean environment in order to utilize their full range of capabilities.
3. Handling of interchangeable types
 - ① Interchangeable ball slide will be delivered with a provisional rail (inserting fixture).
 - ② Do not remove the ball slide from provisional rail until inserting into a rail.
 - ③ Be sure to use the provisional rail when removing ball slide(s) form a rail.

SH-AN (High load type) / SH-BN (Super high load type)

Reference number

Example: **SH 30 1000 AN C 2 - * PC Z**

Series name: SH
 Size: 30
 Rail length (mm): 1000
 Ball slide shape/height: AN
 Material/surface treatment: C
 Accuracy grade: *
 Design serial number: PC
 Preload: Z
 Number of ball slides per rail: 2

C: Special carbon steel (NSK standard)
 K: Stainless steel (LH15 to LH30 only)

Reference number for rail of interchangeable types

For regular rails (non-jointed rail)

Example: **L 1 H 30 1000 S Z**

Interchangeable ball slide: L
 Series name: H
 Size: 30
 Rail length (mm): 1000
 Material: S
 Preload: Z

S: Stainless steel
 No code: Special carbon steel (NSK standard)

For more details regarding joint rails, please contact us.

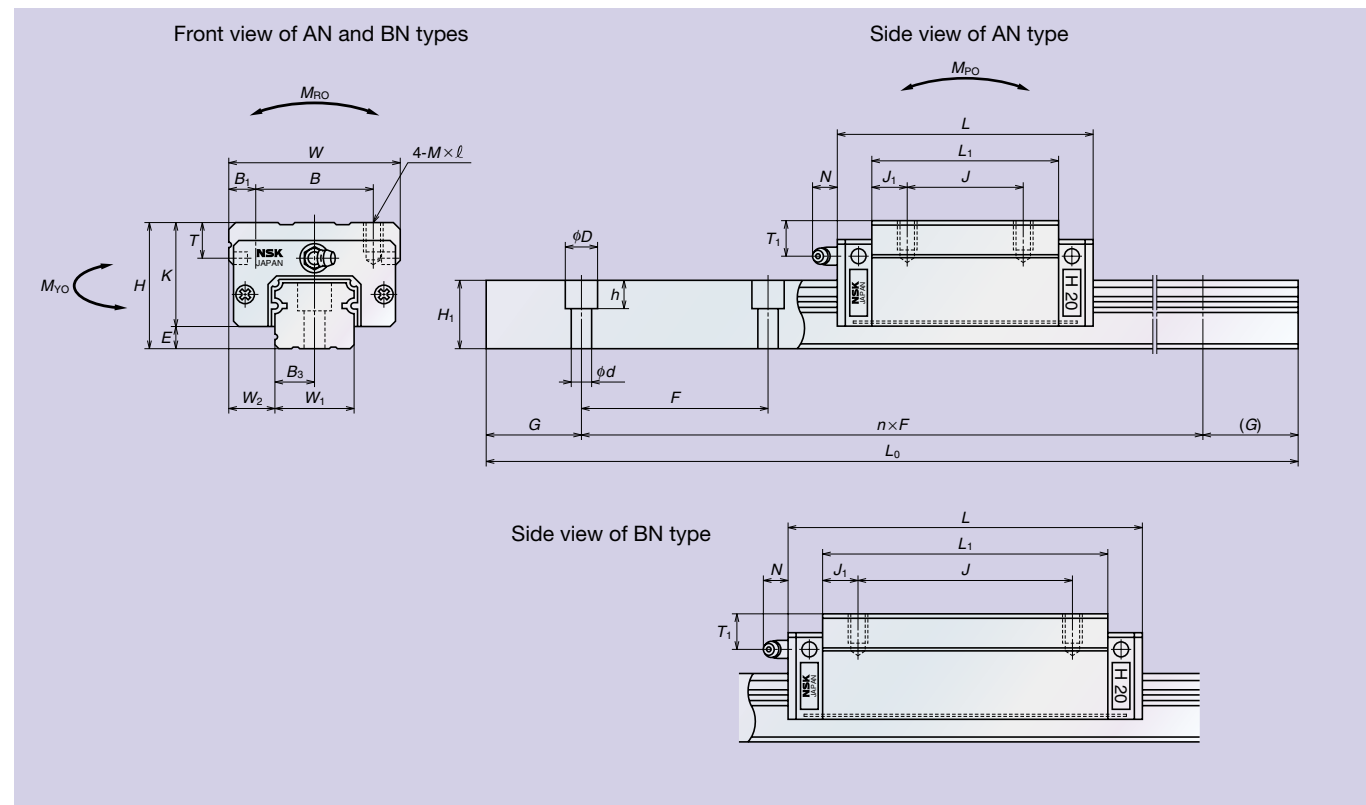

Reference number for ball slide of interchangeable types

Example: **S A H 30 AN S Z**

Interchangeable ball slide: S
 Series name: A
 Size: H
 Ball slide shape/height: 30
 Material: AN
 Preload: S
 Preload Z: Slight preload

S: Stainless steel
 No code: Special carbon steel (NSK standard)

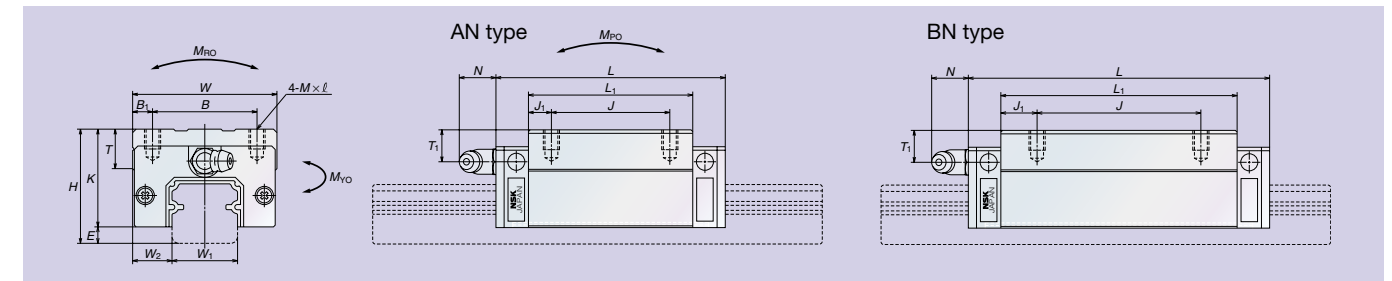

Model No.	Assembly			Ball slide													Rail					Basic load rating					Ball diameter D_w	Weight				
	Height H	E	W_2	Width W	Length L	Mounting tap hole				B_1	L_1	J_1	K	T	Grease fitting			Width W_1	Height H_1	Pitch F	Mounting bolt hole $d \times D \times h$	B_3	G (recommended)	Max. length L_{omax} () for stainless	Dynamic C (N)	Static C_0 (N)		Static moment			Ball slide (kg)	Rail (kg/m)
						B	J	$M \times \text{pitch} \times \ell$	Hole size						T_1	N	M_{RO} (N·m)											M_{PO} (N·m)	M_{VO} (N·m)			
SH15AN SAH15AN	28	4.6	9.5	34	55	26	26	M4×0.7×6	4	39	6.5	23.4	8	∅3	8.5	3.3	15	15	60	4.5×7.5×5.3	7.5	20	2 000 (1 800)	7 800 10 900	14 700 23 500	89 143	65 158	65 157	3.175	0.18 0.26	1.6	
SH15BN SAH15BN					74					58	16																					58
SH20AN SAH20AN	30	5	12	44	69.8	32	M5×0.8×6	6	50	7	25	12	M6×0.75	5	11	20	18	60	6×9.5×8.5	10	20	3 960 (3 500)	13 400 17 500	22 800 37 000	196 284	157 323	157 323	3.968	0.33 0.48	2.6		
SH20BN SAH20BN					91.8				50	11																					58	11.5
SH25AN SAH25AN	40	7	12.5	48	79	35	M6×1×9	6.5	58	11.5	33	12	M6×0.75	10	11	23	22	60	7×11×9	11.5	20	3 960 (3 500)	19 800 25 800	36 000 49 100	333 451	284 519	284 510	4.762	0.55 0.82	3.6		
SH25BN SAH25BN					107				50	18																					58	18
SH30AN SAH30AN	45	9	16	60	85.6	40	M8×1.25×10	10	59	9.5	36	14	M6×0.75	10	11	28	26	80	9×14×12	14	20	4 000 (3 500)	23 900 35 800	40 300 67 200	451 745	304 794	304 784	5.556	0.77 1.3	5.2		
SH30BN SAH30BN					124.6				60	19																					59	19
SH35AN SAH35AN	55	9.5	18	70	109	50	M8×1.25×12	10	80	15	45.5	15	M6×0.75	15	11	34	29	80	9×14×12	17	20	4 000	36 600 47 600	63 100 91 800	868 1 260	624 1 265	614 1 235	6.35	1.5 2.1	7.2		
SH35BN SAH35BN					143				72	21																					80	21

SH-AL (High load type) / SH-BL (Super high load type)

Reference number

Example: **SH 30 1000 AL C 2 - * PC Z**

Series name: SH
 Size: 30
 Rail length (mm): 1000
 Ball slide shape/height: AL
 Material/surface treatment: C
 Accuracy grade: *
 Design serial number: PC
 Preload: Z
 Number of ball slides per rail: 2

C: Special carbon steel (NSK standard)
 K: Stainless steel (LH15 to LH30 only)

Reference number for rail of interchangeable types

For regular rails (non-jointed rail)

Example: **L 1 H 30 1000 S Z**

Interchangeable ball slide: L
 Series name: H
 Size: 30
 Material: S
 Preload: Z
 Rail length (mm): 1000

S: Stainless steel
 No code: Special carbon steel (NSK standard)

For more details regarding joint rails, please contact us.

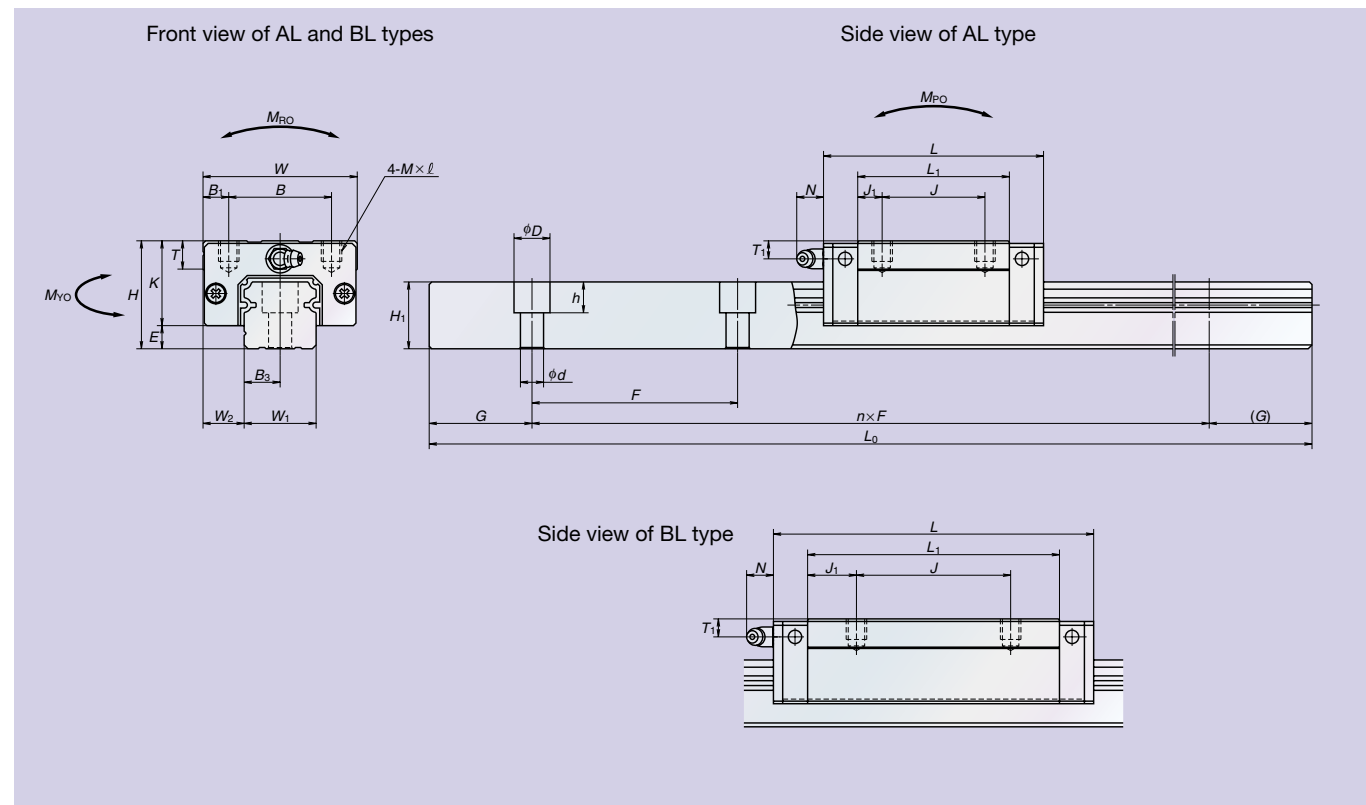

Reference number for ball slide of interchangeable types

Example: **S A H 30 AL S Z**

Interchangeable bearing: S
 Series name: A
 Size: H
 Material: S
 Preload: Z
 Ball slide shape/height: AL

S: Stainless steel
 No code: Special carbon steel (NSK standard)

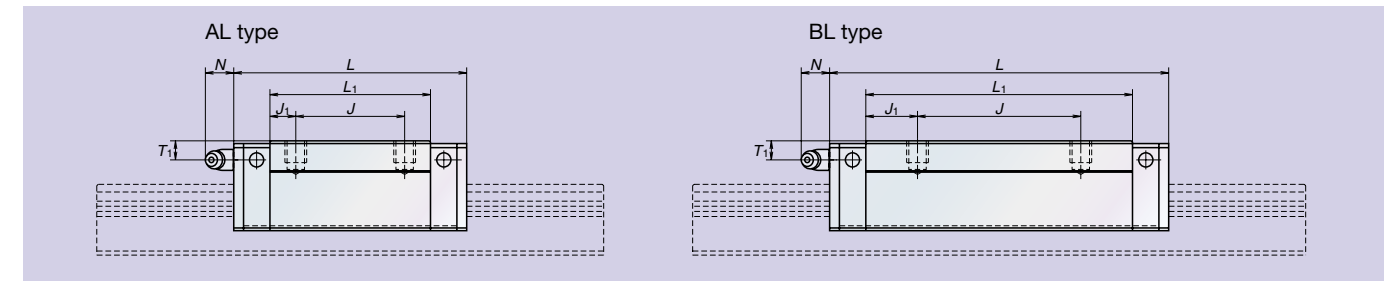

Model No.	Assembly			Ball slide													Rail					Basic load rating					Ball diameter D_w	Weight			
	Height H	E	W_2	Width W	Length L	Mounting tap hole			B_1	L_1	J_1	K	T	Grease fitting			Width W_1	Height H_1	Pitch F	Mounting bolt hole $d \times D \times h$	B_3	G (recommended)	Max. length L_{omax} () for stainless	Dynamic C (N)	Static C_0 (N)	Static moment			Ball slide (kg)	Rail (kg/m)	
						B	J	$M \times \text{pitch} \times l$						Hole size	T_1	N										M_{RO} (N·m)		M_{PO} (N·m)			M_{VO} (N·m)
SH25AL SAH25AL	36	7	12.5	48	79	35	35	$M6 \times 1 \times 6$	6.5	58	11.5	29	12	$M6 \times 0.75$	6	11	23	22	60	$7 \times 11 \times 9$	11.5	20	3 960 (3 500)	19 800	36 000	333	284	284	4.762	0.55	3.6
SH25BL SAH25BL					107					50	86															18	8	11			
SH30AL SAH30AL	42	9	16	60	85.6	40	$M8 \times 1.25 \times 8$	10	59	9.5	33	14	$M6 \times 0.75$	7	11	28	26	80	$9 \times 14 \times 12$	14	20	4 000 (3 500)	23 900	40 300	451	304	304	5.556	0.77	5.2	
SH30BL SAH30BL					124.6				60	98															19	8	11				28
SH35AL SAH35AL	48	9.5	18	70	109	50	$M8 \times 1.25 \times 8$	10	80	15	38.5	15	$M6 \times 0.75$	8	11	34	29	80	$9 \times 14 \times 12$	17	20	4 000	36 600	63 100	868	624	614	6.35	1.5	7.2	
SH35BL SAH35BL					143				72	114															21	8	11				34

SH-EL (High load type) / SH-GL (Super high load type)

Reference number

Example: **SH 30 1000 EL C - * PC Z**

Series name: SH
 Size: 30
 Rail length (mm): 1000
 Ball slide shape/height: EL
 Material/surface treatment: C
 Preload: *
 Accuracy grade: PC
 Design serial number: Z
 Number of ball slides per rail: -

Material/surface treatment:
 C: Special carbon steel (NSK standard)
 K: Stainless steel (LH15 to LH30 only)

Reference number for rail of interchangeable types

For regular rails (non-jointed rail)

Example: **L 1 H 30 1000 S Z**

Interchangeable ball slide: L
 Series name: H
 Size: 30
 Preload: Z
 Material: S
 Rail length (mm): 1000

S: Stainless steel
 No code: Special carbon steel (NSK standard)

For more details regarding joint rails, please contact us.

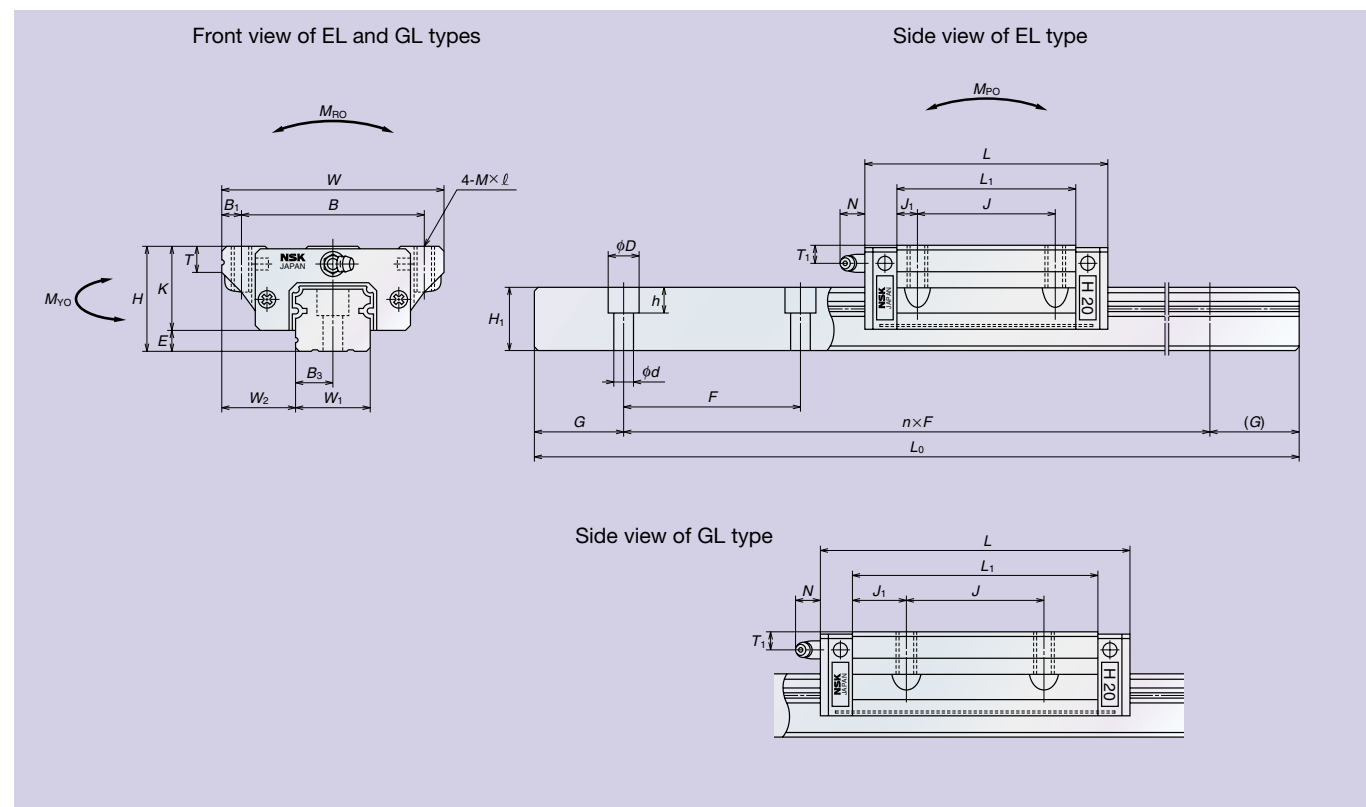

Reference number for ball slide of interchangeable types

Example: **S A H 30 EL S Z**

Interchangeable bearing: S
 Series name: A
 Size: H
 Preload: Z
 Material: S
 Ball slide shape/height: EL

S: Stainless steel
 No code: Special carbon steel (NSK standard)

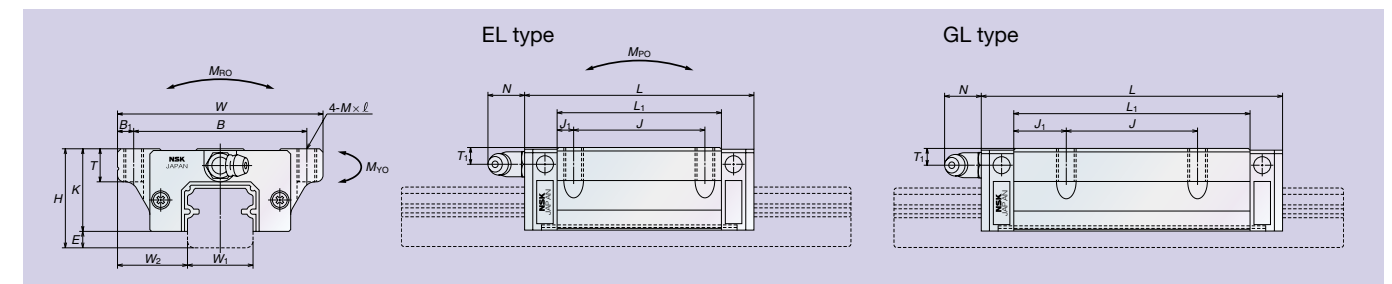

Model No.	Assembly			Ball slide										Rail					Basic load rating					Ball diameter D_w	Weight						
	Height H	E	W_2	Width W	Length L	Mounting tap hole				B_1	L_1	J_1	K	T	Grease fitting			Width W_1	Height H_1	Pitch F	Mounting bolt hole $d \times D \times h$	B_3	G (recommended)		Max. length L_{omax} () for stainless	Dynamic C (N)	Static C_0 (N)	Static moment			Ball slide (kg)
						B	J	$M \times \text{pitch} \times l$	Hole size						T_1	N	M_{RO} (N·m)							M_{PO} (N·m)				M_{VO} (N·m)			
SH15EL SAH15EL	24	4.6	16	47	55	38	30	M5×0.8×8	4.5	39	4.5	19.4	8	ø3	4.5	3.3	15	15	60	4.5×7.5×5.3	7.5	20	2 000 (1 800)	7 800 10 900	14 700 23 500	89 143	65 158	65 157	3.175	0.17 0.25	1.6
SH15GL SAH15GL					74					58	14																				
SH20EL SAH20EL	30	5	21.5	63	69.8	53	40	M6×1×10	5	50	5	25	10	M6×0.75	5	11	20	18	60	6×9.5×8.5	10	20	3 960 (3 500)	13 400 17 500	22 800 37 000	196 284	157 323	157 323	3.968	0.45 0.65	2.6
SH20GL SAH20GL					91.8					72	16																				
SH25EL SAH25EL	36	7	23.5	70	79	57	45	M8×1.25×16 (M8×1.25×12)	6.5	58	6.5	29	11	M6×0.75	6	11	23	22	60	7×11×9	11.5	20	3 960 (3 500)	19 800 25 800	36 000 49 100	333 451	284 519	284 510	4.762	0.63 0.93	3.6
SH25GL SAH25GL					107					86	20.5																				
SH30EL SAH30EL	42	9	31	90	98.6	72	52	M10×1.5×18 (M10×1.5×15)	9	72	10	33	11	M6×0.75	7	11	28	26	80	9×14×12	14	20	4 000 (3 500)	27 600 35 800	49 300 67 200	549 745	441 794	441 784	5.556	1.2 1.6	5.2
SH30GL SAH30GL					124.6					98	23																				
SH35EL SAH35EL	48	9.5	33	100	109	82	62	M10×1.5×20	9	80	9	38.5	12	M6×0.75	8	11	34	29	80	9×14×12	17	20	4 000 (3 500)	36 600 47 600	63 100 91 800	868 1 260	624 1 265	614 1 235	6.35	1.7 2.4	7.2
SH35GL SAH35GL					143					114	26																				

Dimensions in () are applicable to stainless steel products.

SH-FL (High load type) / SH-HL (Super high load type)

Reference number

Example: **SH 30 1000 FL C 2 - * PC Z**

Series name: SH
 Size: 30
 Rail length (mm): 1000
 Ball slide shape/height: FL
 Material/surface treatment: C
 Accuracy grade: 2
 Design serial number: *
 Material/surface treatment: PC
 Preload: Z

Material/surface treatment:
 C: Special carbon steel (NSK standard)
 K: Stainless steel (LH15 to LH30 only)

Reference number for rail of interchangeable types

For regular rails (non-jointed rail)

Example: **L 1 H 30 1000 S Z**

Interchangeable ball slide: L
 Series name: H
 Size: 30
 Material: S
 Preload: Z

S: Stainless steel
 No code: Special carbon steel (NSK standard)

For more details regarding joint rails, please contact us.

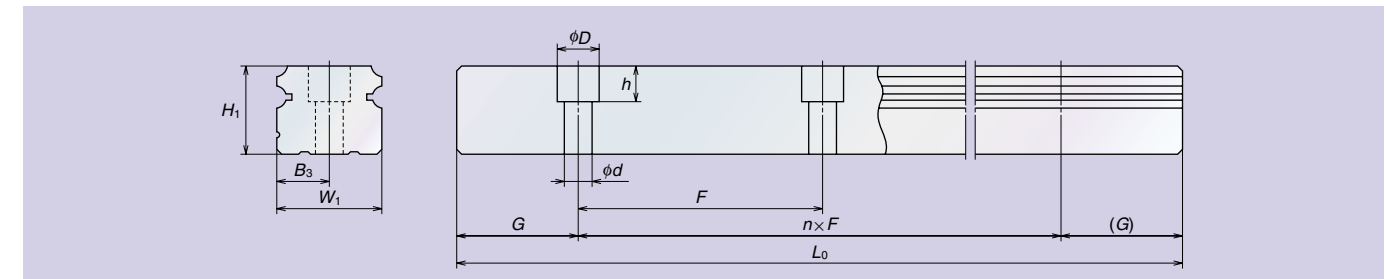
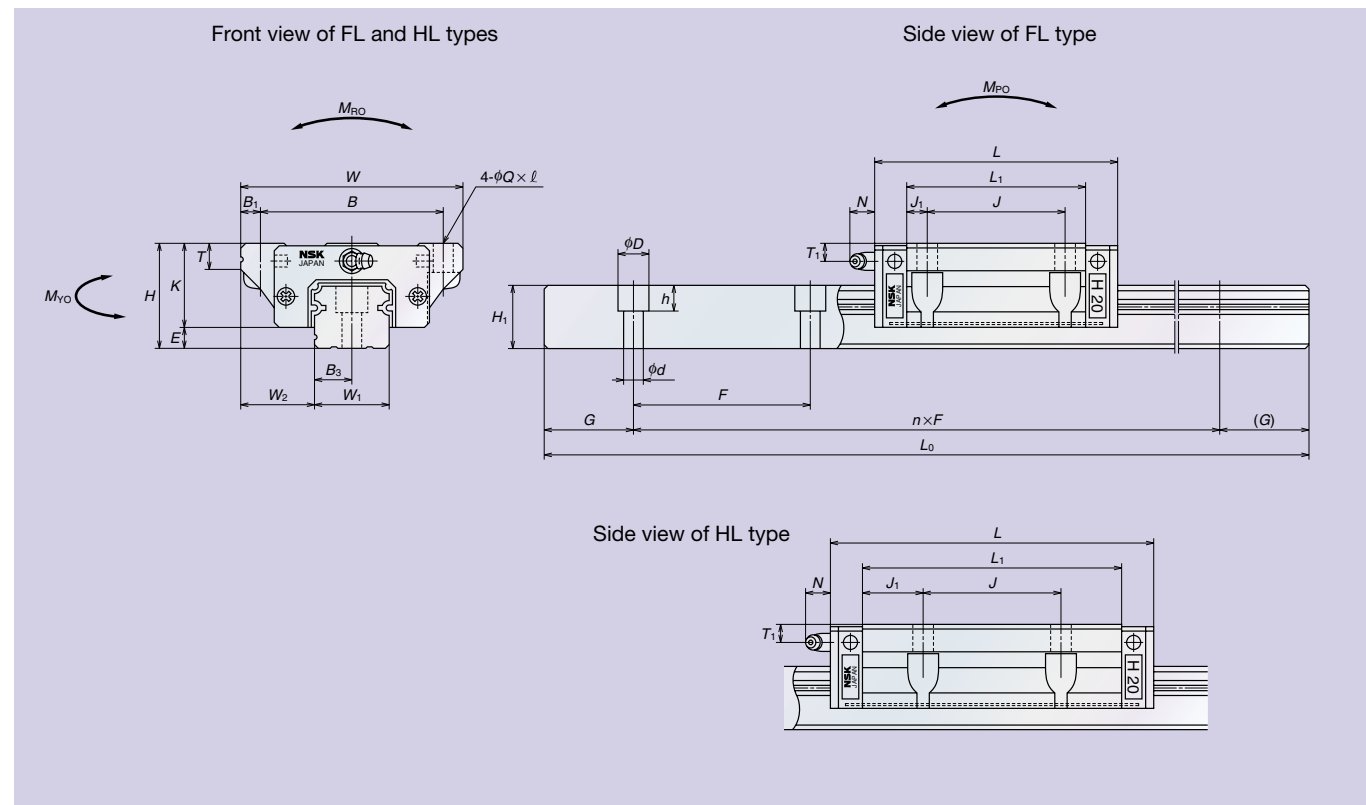

Reference number for ball slide of interchangeable types

Example: **S A H 30 FL S Z**

Interchangeable bearing: S
 Series name: A
 Size: H
 Ball slide shape/height: 30 FL
 Material: S
 Preload: Z

S: Stainless steel
 No code: Special carbon steel (NSK standard)

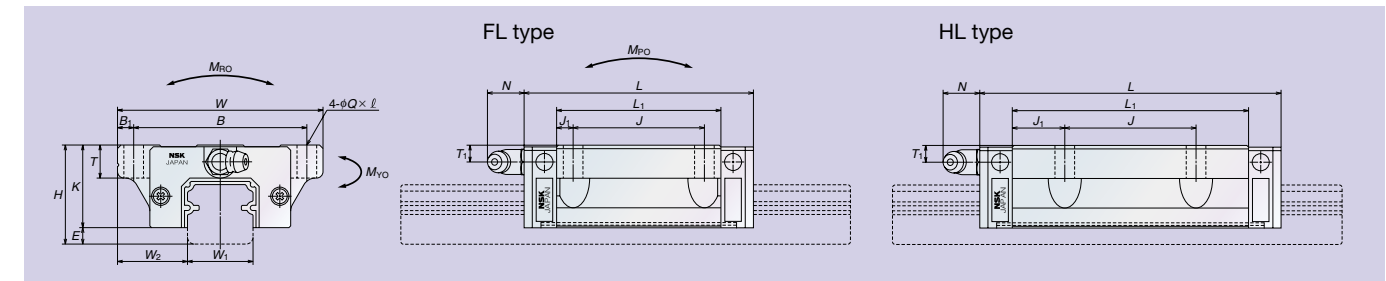

Model No.	Assembly			Ball slide										Rail					Basic load rating					Ball diameter D_w	Weight						
	Height H	E	W_2	Width W	Length L	Mounting tap hole			B_1	L_1	J_1	K	T	Grease fitting			Width W_1	Height H_1	Pitch F	Mounting bolt hole $d \times D \times h$	B_3	G (recommended)	Max. length L_{omax} () for stainless		Dynamic C (N)	Static C_0 (N)	Static moment			Ball slide (kg)	Rail (kg/m)
						B	J	$Q \times l$						Hole size	T_1	N								M_{RO} (N·m)			M_{PO} (N·m)	M_{VO} (N·m)			
SH15FL SAH15FL	24	4.6	16	47	55	38	30	4.5×7	4.5	39	4.5	19.4	8	∅3	4.5	3.3	15	15	60	4.5×7.5×5.3	7.5	20	2 000 (1 800)	7 800 10 900	14 700 23 500	89 143	65 158	65 157	3.175	0.17 0.25	1.6
SH15HL SAH15HL					74					58	14																				
SH20FL SAH20FL	30	5	21.5	63	69.8	53	40	6×10	5	50	5	25	10	M6×0.75	5	11	20	18	60	6×9.5×8.5	10	20	3 960 (3 500)	13 400 17 500	22 800 37 000	196 284	157 323	157 323	3.968	0.45 0.65	2.6
SH20HL SAH20HL					91.8					72	16																				
SH25FL SAH25FL	36	7	23.5	70	79	57	45	7×10	6.5	58	6.5	29	11	M6×0.75	6	11	23	22	60	7×11×9	11.5	20	3 960 (3 500)	19 800 25 800	36 000 49 100	333 451	284 519	284 510	4.762	0.63 0.93	3.6
SH25HL SAH25HL					107					86	20.5																				
SH30FL SAH30FL	42	9	31	90	98.6	72	52	9×12	9	72	10	33	11	M6×0.75	7	11	28	26	80	9×14×12	14	20	4 000 (3 500)	27 600 35 800	49 300 67 200	549 745	441 794	441 784	5.556	1.2 1.6	5.2
SH30HL SAH30HL					124.6					98	23																				
SH35FL SAH35FL	48	9.5	33	100	109	82	62	9×13	9	80	9	38.5	12	M6×0.75	8	11	34	29	80	9×14×12	17	20	4 000	36 600 47 600	63 100 91 800	868 1 260	624 1 265	614 1 235	6.35	1.7 2.4	7.2
SH35HL SAH35HL					143					114	26																				

Dimensions in () are applicable to stainless steel products.

SS-AL (High load type) / SS-CL (medium load type)

Reference number

Example: **SS 30 1000 AL C 2 - * PC Z**

Series name: SS
 Size: 30
 Rail length (mm): 1000
 Ball slide shape/height: AL
 Material/surface treatment: C
 Design serial number: 2
 Accuracy grade: *
 Preload: PC
 Number of ball slides per rail: Z
 Material/surface treatment: C: Special carbon steel (NSK standard), K: Stainless steel

Reference number for rail of interchangeable types

For regular rails (non-jointed rail)
 Example: **L 1 S 15 1000 T S Z**

Interchangeable rail: L
 Series name: 1
 Size: S
 Rail length (mm): 15
 Accuracy grade: 1000
 Preload: T
 Material/surface treatment: S
 Design serial number: S
 Number of ball slides per rail: Z

Z: Preload
 S: Stainless steel
 No code: Special carbon steel (NSK standard)
 Applicable only to L1S15 (no code for other sizes)
 T: With M4-bolt holes for rail mounting
 No code: With M3-bolt holes for rail mounting

For more details regarding joint rails, please contact us.

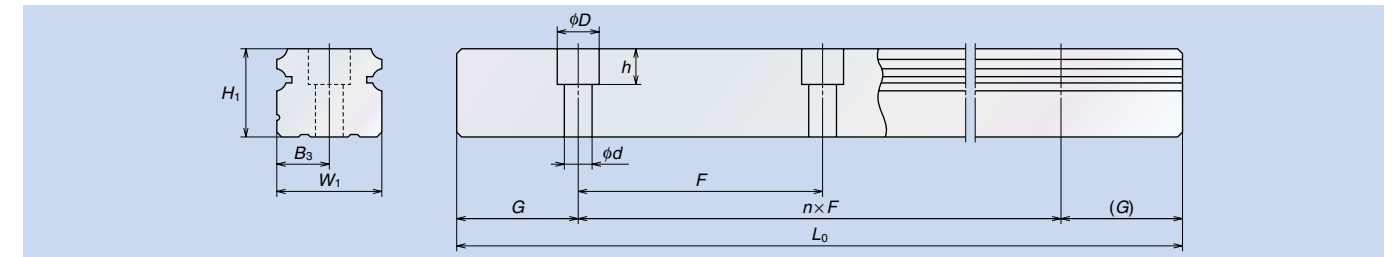
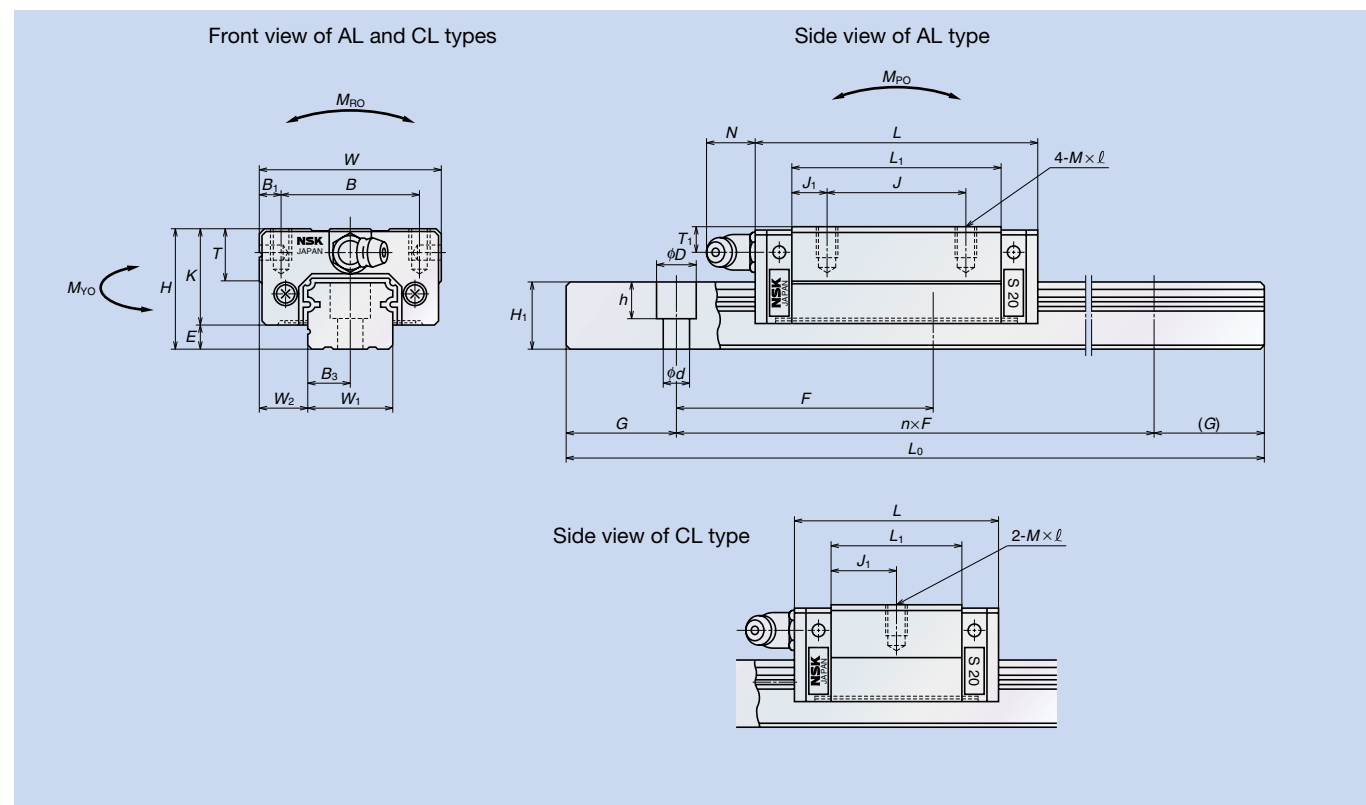

Reference number for ball slide of interchangeable types

Example: **S A S 30 AL S Z**

Interchangeable bearing: S
 Series name: A
 Size: S
 Rail length (mm): 30
 Ball slide shape/height: AL
 Preload: S
 Material/surface treatment: S
 Design serial number: Z

Preload Z: Slight preload
 S: Stainless steel
 No code: Special carbon steel (NSK standard)
 Ball slide shape/height

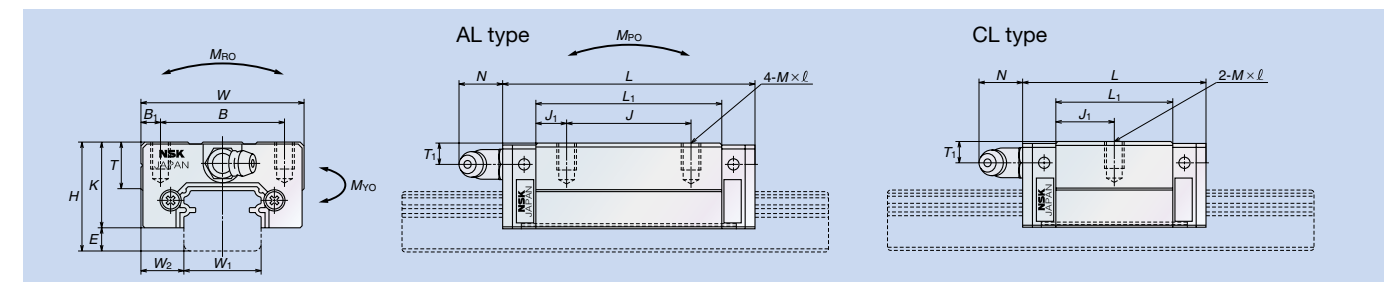

Model No.	Assembly			Ball slide										Rail						Basic load rating					Ball diameter D_w	Weight						
	Height H	E	W_2	Width W	Length L	Mounting tap hole				B_1	L_1	J_1	K	T	Grease fitting			Width W_1	Height H_1	Pitch F	Mounting bolt hole $d \times D \times h$	B_3	G (recommended)	Max. length L_{omax} () for stainless		Dynamic C (N)	Static C_0 (N)	Static moment			Ball slide (kg)	Rail (kg/m)
						B	J	$M \times \text{pitch} \times l$	Hole size						T_1	N	M_{RO} (N·m)											M_{PO} (N·m)	M_{VO} (N·m)			
SS15CL SAS15CL	24	4.6	9.5	34	40.4	26	—	M4×0.7×6	4	23.6	11.8	19.4	10	∅3	6	3	15	12.5	60	3.5×6×4.5 4.5×7.5×5.3	7.5	20	2 000 (1 700)	4 150 6 350	7 250 11 400	39 69	20 49	20 49	2.778	0.14 0.2	1.4	
SS15AL SAS15AL						26	M4×0.7×6	40																								7
SS20CL SAS20CL	28	6	11	42	47.2	32	—	M5×0.8×7	5	30	15	22	12	M6×0.75	5.5	11	20	15.5	60	6×9.5×8.5	10	20	3 960 (3 500)	6 050 8 500	10 700 16 100	69 118	29 88	29 88	3.175	0.19 0.28	2.3	
SS20AL SAS20AL						32	M5×0.8×7	48																								8
SS25CL SAS25CL	33	7	12.5	48	59.6	35	—	M6×1×9	6.5	38	19	26	12	M6×0.75	7	11	23	18	60	7×11×9	11.5	20	3 960 (3 500)	9 750 13 700	16 600 27 000	127 235	59 196	59 186	3.968	0.34 0.51	3.1	
SS25AL SAS25AL						35	M6×1×9	60																								12.5
SS30CL SAS30CL	42	9	16	60	67.4	40	—	M8×1.25×12	10	42	21	33	13	M6×0.75	8	11	28	23	80	7×11×9	14	20	4 000 (3 500)	14 500 22 300	22 900 39 200	216 441	98 323	98 323	4.762	0.58 0.85	4.8	
SS30AL SAS30AL						40	M8×1.25×12	71																								15.5
SS35CL SAS35CL	48	10.5	18	70	77	50	—	M8×1.25×12	10	49	24.5	37.5	14	M6×0.75	8.5	11	34	27.5	80	9×14×12	17	20	4 000 (3 500)	20 200 31 000	31 400 53 800	362 724	139 492	139 487	5.556	0.86 1.3	7	
SS35AL SAS35AL						50	M8×1.25×12	80																								15

* SS15 mounting bolt hole is applicable to M3 (3.5×6×4.5) and M4 (4.5×7.5×5.3).

SS-EL (High load type) / SS-JL (Medium load type)

Reference number

Example: **SS 30 1000 EL C 2 - * PC Z**

Series name: SS
 Size: 30
 Rail length (mm): 1000
 Ball slide shape/height: EL
 Material/surface treatment: C
 Number of ball slides per rail: 2
 Accuracy grade: *
 Design serial number: PC
 Preload: Z
 Material/surface treatment:
 C: Special carbon steel (NSK standard)
 K: Stainless steel

Reference number for rail of interchangeable types

For regular rails (non-jointed rail)
 Example: **L 1 S 15 1000 T S Z**

Interchangeable rail: L
 Series name: 1
 Size: S
 Rail length (mm): 15
 1000
 T
 S
 Z: Preload
 S: Stainless steel
 No code: Special carbon steel (NSK standard)
 Applicable only to L1S15 (no code for other sizes)
 T: With M4-bolt holes for rail mounting
 No code: With M3-bolt holes for rail mounting

For more details regarding joint rails, please contact us.

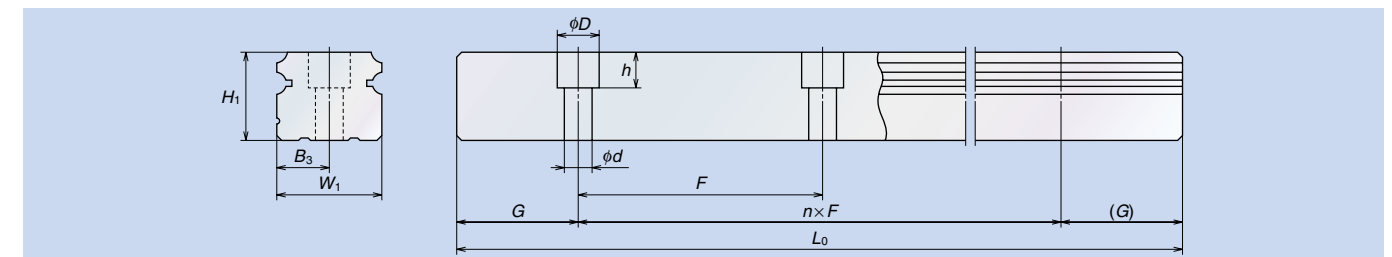
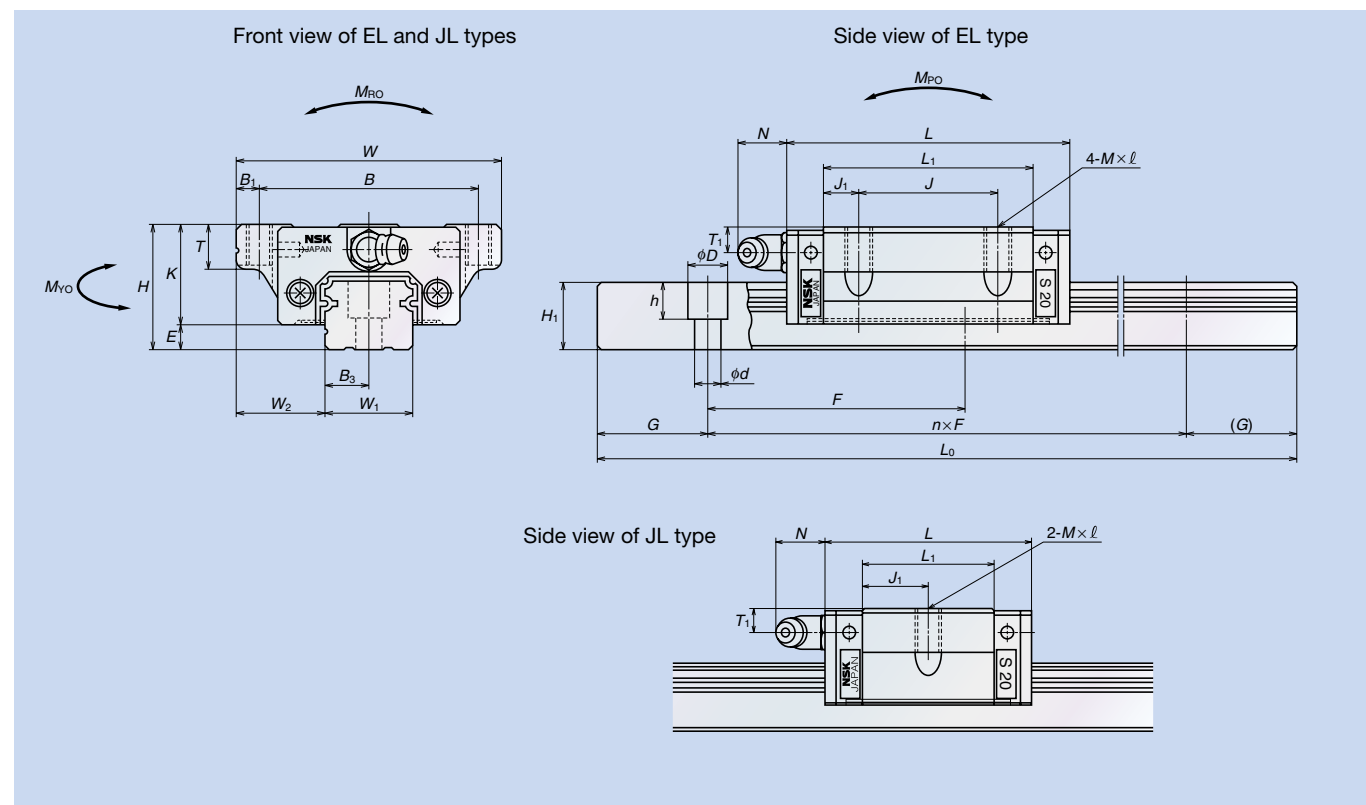

Reference number for ball slide of interchangeable types

Example: **S A S 30 EL S Z**

Interchangeable bearing: S
 Series name: A
 Size: S
 30
 EL
 S
 Z: Preload Z: Slight preload
 S: Stainless steel
 No code: Special carbon steel (NSK standard)
 Ball slide shape/height

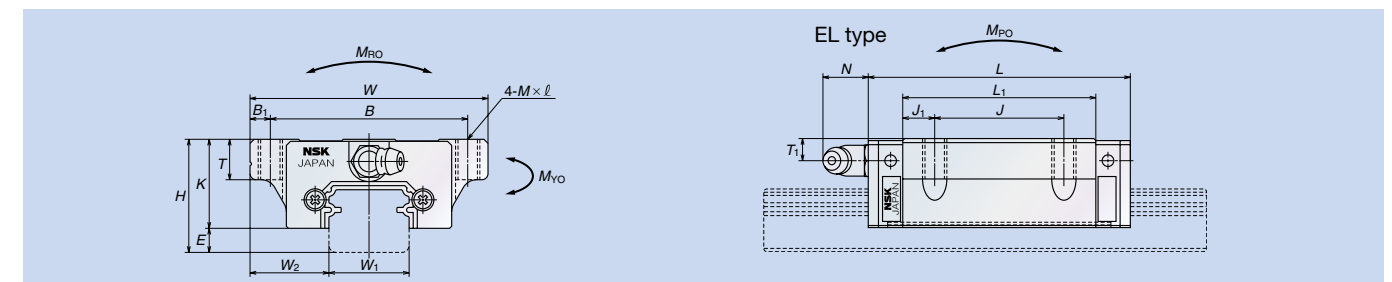

Model No.	Assembly			Ball slide											Rail						Basic load rating					Ball diameter D_w	Weight			
	Height H	E	W_2	Width W	Length L	Mounting tap hole					Grease fitting			Width W_1	Height H_1	Pitch F	Mounting bolt hole $d \times D \times h$	B_3	G (recommended)	Max. length L_{omax} () for stainless	Dynamic C (N)	Static C_0 (N)	Static moment				Ball slide (kg)	Rail (kg/m)		
						B	J	$M \times \text{pitch} \times l$	B_1	L_1	J_1	K	T										Hole size	T_1	N	M_{RO} (N·m)			M_{PO} (N·m)	M_{VO} (N·m)
SS15JL SS15EL SAS15EL	24	4.6	18.5	52	40.4 56.8	41 26	— M5×0.8×6	5.5	23.6 40	11.8 7	19.4	8	$\phi 3$	6	3	15	12.5	60	3.5×6×4.5 4.5×7.5×5.3	7.5	20	2 000 (1 700)	4 150 6 350	7 250 11 400	39 69	20 49	20 49	2.778	0.17 0.26	1.4
SS20JL SS20EL SAS20EL	28	6	19.5	59	47.2 65.2	49 32	— M6×1×10	5	30 48	15 8	22	10	M6×0.75	5.5	11	20	15.5	60	6×9.5×8.5	10	20	3 960 (3 500)	6 050 8 500	10 700 16 100	69 118	29 88	29 88	3.175	0.24 0.35	2.3
SS25JL SS25EL SAS25EL	33	7	25	73	59.6 81.6	60 35	— M8×1.25×12	6.5	38 60	19 12.5	26	11 (12)	M6×0.75	7	11	23	18	60	7×11×9	11.5	20	3 960 (3 500)	9 750 13 700	16 600 27 000	127 235	59 196	59 186	3.968	0.44 0.66	3.1
SS30JL SS30EL SAS30EL	42	9	31	90	67.4 96.4	72 40	— (M10×1.5×15)	9	42 71	21 15.5	33	11 (15)	M6×0.75	8	11	28	23	80	7×11×9	14	20	4 000 (3 500)	14 500 22 300	22 900 39 200	216 441	98 323	98 323	4.762	0.76 1.2	4.8
SS35JL SS35EL SAS35EL	48	10.5	33	100	77 108	82 50	— (M10×1.5×15)	9	49 80	24.5 15	37.5	12 (15)	M6×0.75	8.5	11	34	27.5	80	9×14×12	17	20	4 000 (3 500)	20 200 31 000	31 400 53 800	362 724	139 492	139 487	5.556	1.2 1.7	7

* SS15 mounting bolt hole is applicable to M3 (3.5×6×4.5) and M4 (4.5×7.5×5.3).

Dimensions in () are applicable to stainless steel products.

SS-FL (High load type) / SS-KL (Medium load type)

Reference number

Example: **SS 30 1000 FL C 2 - * PC Z**

Series name: SS
 Size: 30
 Rail length (mm): 1000
 Ball slide shape/height: FL
 Material/surface treatment: C
 Number of ball slides per rail: 2
 Accuracy grade: *
 Design serial number: PC
 Preload: Z
 Material/surface treatment: C: Special carbon steel (NSK standard), K: Stainless steel

Reference number for rail of interchangeable types

For regular rails (non-jointed rail)
 Example: **L 1 S 15 1000 T S Z**

Interchangeable rail: L
 Series name: 1
 Size: S
 Rail length (mm): 15
 Accuracy grade: 1000
 Design serial number: T
 Material/surface treatment: S
 Preload: Z

S: Stainless steel
 No code: Special carbon steel (NSK standard)
 Applicable only to L1S15 (no code for other sizes)
 T: With M4-bolt holes for rail mounting
 No code: With M3-bolt holes for rail mounting

For more details regarding joint rails, please contact us.

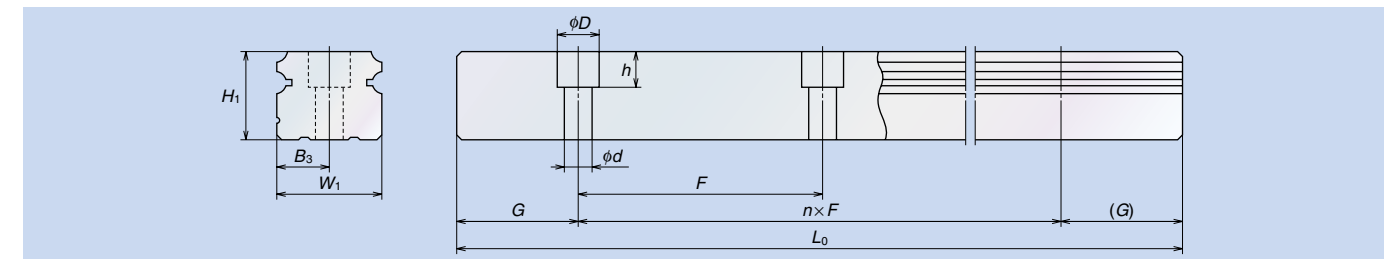
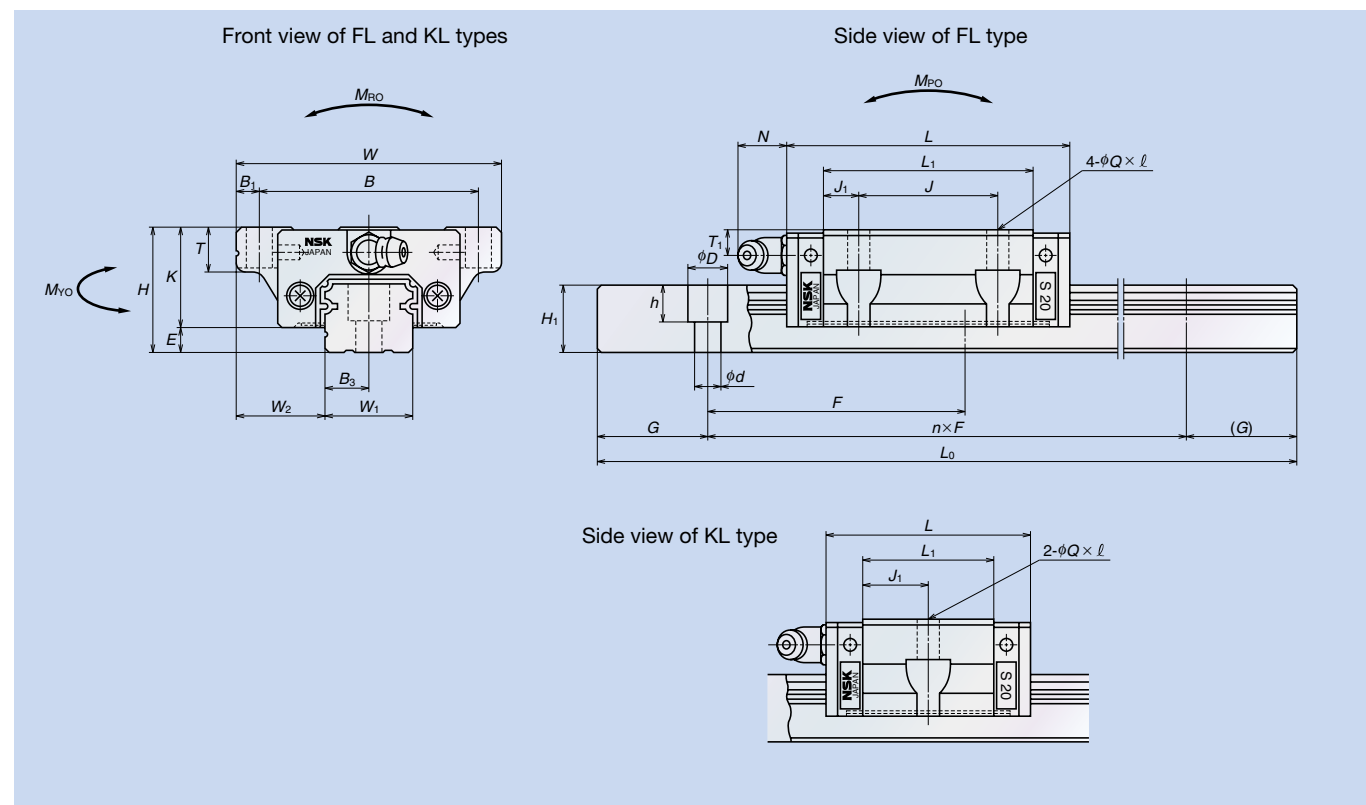

Reference number for ball slide of interchangeable types

Example: **S A S 30 FL S Z**

Interchangeable bearing: S
 Series name: A
 Size: S
 Rail length (mm): 30
 Accuracy grade: FL
 Design serial number: S
 Preload: Z

S: Stainless steel
 No code: Special carbon steel (NSK standard)
 Preload Z: Slight preload
 Ball slide shape/height

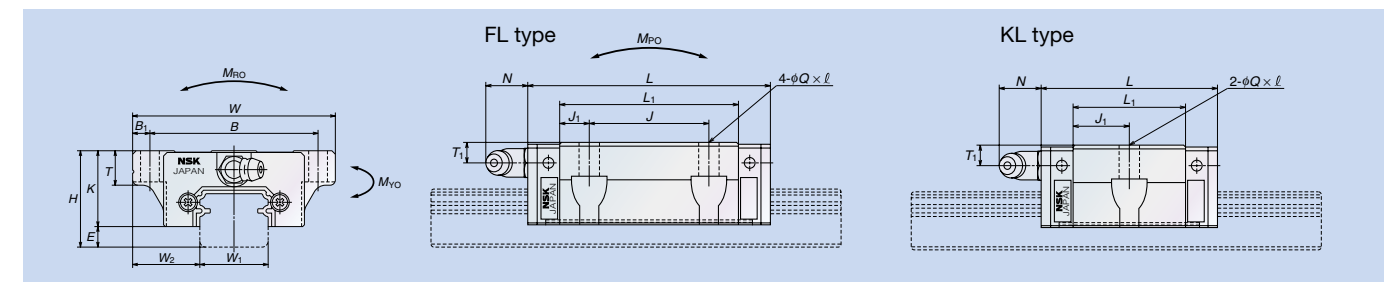

Model No.	Assembly			Ball slide										Rail						Basic load rating					Ball diameter D_w	Weight					
	Height H	E	W_2	Width W	Length L	Mounting tap hole			B_1	L_1	J_1	K	T	Grease fitting			Width W_1	Height H_1	Pitch F	Mounting bolt hole $d \times D \times h$	B_3	G (recommended)	Max. length L_{omax} () for stainless	Dynamic C (N)		Static C_0 (N)	Static moment			Ball slide (kg)	Rail (kg/m)
						B	J	$Q \times \ell$						Hole size	T_1	N									M_{RO} (N·m)		M_{PO} (N·m)	M_{VO} (N·m)			
SS15KL SAS15KL	24	4.6	18.5	52	40.4	41	—	4.5×7	5.5	23.6	11.8	19.4	8	ø3	6	3	15	12.5	60	3.5×6×4.5 4.5×7.5×5.3	7.5	20	2 000 (1 700)	4 150 6 350	7 250 11 400	39 69	20 49	20 49	2.778	0.17 0.26	1.4
SS15FL SAS15FL					56.8		26			40	7																				
SS20KL SAS20KL	28	6	19.5	59	47.2	49	—	5.5×9 (5.5×9.5)	5	30	15	22	10	M6×0.75	5.5	11	20	15.5	60	6×9.5×8.5	10	20	3 960 (3 500)	6 050 8 500	10 700 16 100	69 118	29 88	29 88	3.175	0.35	2.3
SS20FL SAS20FL				65.2	32		48			8	20																				
SS25KL SAS25KL	33	7	25	73	59.6	60	—	7×10 (7×11.5)	6.5	38	19	26	11	M6×0.75	7	11	23	18	60	7×11×9	11.5	20	3 960 (3 500)	9 750 13 700	16 600 27 000	127 235	59 196	59 186	3.968	0.44 0.66	3.1
SS25FL SAS25FL				81.6	35		60			12.5	20																				
SS30KL SAS30KL	42	9	31	90	67.4	72	—	9×12 (9×14.5)	9	42	21	33	11	M6×0.75	8	11	28	23	80	7×11×9	14	20	4 000 (3 500)	14 500 22 300	22 900 39 200	216 441	98 323	98 323	4.762	0.76 1.2	4.8
SS30FL SAS30FL				96.4	40		71			15.5	28																				
SS35KL SAS35KL	48	10.5	33	100	77	82	—	9×13 (9×14.5)	9	49	24.5	12	(15)	M6×0.75	8.5	11	34	27.5	80	9×14×12	17	20	4 000 (3 500)	20 200 31 000	31 400 53 800	362 724	139 492	139 487	5.556	1.2 1.7	7
SS35FL SAS35FL				108	50		80			15	34																				

* SS15 mounting bolt hole is applicable to M3 (3.5×6×4.5) and M4 (4.5×7.5×5.3).

Dimensions in () are applicable to stainless steel products.